

## Natural Gas Modulating, Condensing Water Heater Models:

- INN600
- INN800
- INN1060
- INN1350

Applicable to Serial Numbers  
G-12-0693 and Above

Other documents for this product  
include:

- GF-5030 INN Gas Supply Guide
- GF-5050 INN Venting Guide
- GF-5060 INN Elect. Power Guide
- GF-5080 INN Sizing Guide

Revised: 07/16/2012

# USER MANUAL

Installation, Operation and Maintenance

## INNOVATION Series Gas-Fired Water Heaters



AERCO  
**Innovation**  
1060



**Technical Support:**  
(Mon–Fri, 8am–5pm EST)  
**1-800-526-0288**

[www.aerco.com](http://www.aerco.com)

#### **Disclaimer**

The information contained in this manual is subject to change without notice from AERCO International, Inc. AERCO makes no warranty of any kind with respect to this material, including but not limited to implied warranties of merchantability and fitness for a particular application. AERCO International is not liable for errors appearing in this manual. Nor for incidental or consequential damages occurring in connection with the furnishing, performance, or use of this material.

---

**TABLE OF CONTENTS**

**TABLE OF CONTENTS** ..... **3**

**FOREWORD**..... **7**

**CHAPTER 1 SAFETY PRECAUTIONS** ..... **11**

1.1 WARNINGS & CAUTIONS..... 11

1.2 EMERGENCY SHUTDOWN ..... 12

1.3 PROLONGED SHUTDOWN ..... 12

**CHAPTER 2 INSTALLATION** ..... **15**

2.1 INTRODUCTION ..... 15

2.2 RECEIVING THE UNIT ..... 15

2.3 UNPACKING..... 15

2.4 SITE PREPARATION ..... 15

    2.4.1 Installation Clearances ..... 16

    2.4.2 Setting the Unit..... 17

2.5 WATER INLET AND OUTLET PIPING..... 17

    2.5.1 WHM Actuator-Controlled Ball Valve Installation ..... 18

2.6 TEST HOSE BIB CONNECTION ..... 19

2.7 SYSTEM RECIRCULATION LOOP ..... 20

2.8 PRESSURE & TEMPERATURE RELIEF VALVE INSTALLATION ..... 22

2.9 CONDENSATE DRAIN & PIPING..... 22

2.10 GAS SUPPLY PIPING ..... 24

    2.10.1 Gas Supply Specifications..... 24

    2.10.2 Manual Gas Shutoff Valve ..... 24

    2.10.3 External Gas Supply Regulator ..... 25

2.11 AC ELECTRICAL POWER WIRING ..... 25

    2.11.1 Electrical Power Requirements..... 26

2.12 FIELD CONTROL WIRING ..... 27

    2.12.1 OUTDOOR SENSOR IN ..... 28

    2.12.2 AIR TEMP SENSOR ..... 28

    2.12.3 O2 Sensor Terminals..... 28

    2.12.4 Flow +/Flow – ..... 28

    2.12.5 ANALOG IN..... 28

    2.12.6 B.M.S. (PWM) IN..... 29

    2.12.7 SHIELD ..... 29

    2.12.8 mA OUT ..... 29

    2.12.9 RS485 Comm..... 29

    2.12.10 RS232 Comm (TxD/RxD) ..... 29

    2.12.11 VFD/Blower ..... 29

    2.12.12 INTERLOCKS ..... 29

    2.12.13 FAULT RELAY ..... 30

    2.12.14 AUXILIARY (AUX) RELAY CONTACTS ..... 30

2.13 FLUE GAS VENT INSTALLATION..... 30

2.14 COMBUSTION AIR.....	31
2.14.1 Combustion From Outside the Building .....	31
2.14.2 Combustion Air from Inside the Building.....	31
2.15 SEALED COMBUSTION.....	31
<b>CHAPTER 3       OPERATION .....</b>	<b>33</b>
3.1 INTRODUCTION .....	33
3.2 CONTROL PANEL DESCRIPTION.....	33
3.3 CONTROL PANEL MENUS .....	37
3.3.1 Menu Processing Procedure .....	37
3.4 OPERATING MENU .....	40
3.5 SETUP MENU .....	40
3.6 CONFIGURATION MENU.....	41
3.7 WATER HEATER MANAGEMENT (WHM) MENU.....	43
3.8 TUNING MENU.....	43
3.9 START SEQUENCE .....	44
3.10 START/STOP LEVELS .....	46
<b>CHAPTER 4       INITIAL START-UP.....</b>	<b>49</b>
4.1 INITIAL START-UP REQUIREMENTS.....	49
4.2 TOOLS AND INSTRUMENTATION FOR COMBUSTION CALIBRATION .....	49
4.2.1 Required Tools & Instrumentation .....	49
4.2.2 Installing Gas Supply Manometer.....	50
4.2.3 Accessing the Analyzer Probe Port .....	50
4.2.4 Connecting Multimeter to Flame Detector .....	51
4.3 NATURAL GAS COMBUSTION CALIBRATION .....	52
4.4 REASSEMBLY.....	55
4.5 TEMPERATURE CONTROL CALIBRATION .....	55
4.5.1 Setting the Outlet Water Temperature Setpoint.....	56
4.5.2 Minimum Load Adjustment .....	56
4.5.3 Maximum Load Adjustment.....	57
4.6 OVER-TEMPERATURE LIMIT SWITCHES .....	58
<b>CHAPTER 5       SAFETY DEVICE TESTING.....</b>	<b>59</b>
5.1 TESTING OF SAFETY DEVICES .....	59
5.2 LOW GAS PRESSURE FAULT TEST.....	59
5.3 HIGH GAS PRESSURE FAULT TEST.....	60
5.4 LOW WATER LEVEL FAULT TEST.....	61
5.5 WATER TEMPERATURE FAULT TEST .....	61
5.6 INTERLOCK TESTS.....	62
5.6.1 Remote Interlock .....	62
5.6.2 Delayed Interlock.....	63

---

5.7 FLAME FAULT TESTS .....	63
5.8 AIR FLOW FAULT TESTS .....	64
5.9 SSOV PROOF OF CLOSURE SWITCH .....	66
5.10 PURGE SWITCH OPEN DURING PURGE .....	67
5.11 IGNITION SWITCH OPEN DURING IGNITION .....	67
5.12 SAFETY PRESSURE RELIEF VALVE TEST .....	68
<b>CHAPTER 6        MAINTENANCE .....</b>	<b>69</b>
6.1 MAINTENANCE SCHEDULE .....	69
6.2 IGNITER-INJECTOR .....	70
6.2.1 Igniter-Injector Part No. 58023 .....	70
6.2.2 Igniter Part No. 66023 .....	72
6.3 FLAME DETECTOR .....	74
6.4 COMBUSTION CALIBRATION .....	74
6.5 SAFETY DEVICE TESTING .....	74
6.6 FIRESIDE INSPECTION .....	74
6.7 WATERSIDE INSPECTION .....	79
6.8 HEAT EXCHANGER CLEANING .....	81
6.8.1 Pumping System Set-Up Instructions .....	81
6.8.2 Cleaning Procedure .....	82
6.8.3 Testing HydroSkруб Effectiveness .....	83
6.9 CONDENSATE DRAIN TRAP .....	83
6.10 AIR FILTER REPLACEMENT .....	84
6.11 SHUTTING THE WATER HEATER DOWN FOR AN EXTENDED PERIOD OF TIME .....	85
6.12 PLACING THE HEATER BACK IN SERVICE AFTER A PROLONGED SHUTDOWN .....	86
<b>CHAPTER 7        TROUBLESHOOTING GUIDE .....</b>	<b>87</b>
7.1 INTRODUCTION .....	87
7.2 ADDITIONAL FAULTS WITHOUT SPECIFIC FAULT MESSAGES .....	99
<b>CHAPTER 8        RS232 COMMUNICATION .....</b>	<b>103</b>
8.1 INTRODUCTION .....	103
8.2 RS232 COMMUNICATION SETUP .....	103
8.3 MENU PROCESSING UTILIZING RS232 COMMUNICATION .....	103
8.4 DATA LOGGING .....	104
8.4.1 Fault Log .....	104
8.4.2 Operation Time Log .....	105
8.4.3 Sensor Log .....	105

**CHAPTER 9 WATER HEATER MANAGEMENT ..... 107**

9.1 INTRODUCTION ..... 107

9.2 GENERAL DESCRIPTION..... 107

9.3 WHM PRINCIPLES OF OPERATION ..... 108

9.4 WHM MENU ..... 108

9.5 WHM HARDWARE INSTALLATION & SET-UP INSTRUCTIONS ..... 109

    9.5.1 Hardware Installation..... 109

    9.5.2 WHM Modbus Network Wiring..... 110

    9.5.3 Control and Power Wiring..... 110

9.6 WHM MENU SETTINGS..... 112

    9.6.1 WHM Mode ..... 112

    9.6.2 Comm Address (Located in Setup Menu)..... 112

    9.6.3 WHM Setpoint..... 112

    9.6.4 WHM Nxt On VP ..... 112

    9.6.5 WHM Nxt Off VP ..... 112

    9.6.6 Lead/Lag Hours..... 112

    9.6.7 Setback Setpoint ..... 112

    9.6.8 Setback Start & Setback End ..... 112

    9.6.9 WHM Auto Mstr..... 113

    9.6.10 WHM Auto Timer..... 113

9.7 WHM PROGRAMMING & START-UP ..... 113

9.8 TROUBLESHOOTING ..... 115

9.9 SEQUENCING VALVE DESCRIPTION & OPERATION ..... 116

    9.9.1 Sequencing Valve Description..... 116

    9.9.2 Sequencing Valve Operating Characteristics..... 118

**APPENDIX A: INNOVATION MENU ITEM DESCRIPTIONS..... 119**

**APPENDIX B: STARTUP, STATUS AND FAULT MESSAGES ..... 125**

**APPENDIX C: TEMPERATURE SENSOR RESISTANCE/VOLTAGE CHART..... 129**

**TEMPERATURE SENSOR RESISTANCE/VOLTAGE CHART ..... 129**

**APPENDIX D: INNOVATION DEFAULT SETTINGS ..... 131**

**APPENDIX E: PARTS LIST DRAWINGS ..... 133**

**APPENDIX F: PIPING DRAWINGS ..... 147**

**APPENDIX G: C-MORE CONTROL PANEL VIEWS ..... 169**

**APPENDIX H: C-MORE WIRING DIAGRAMS ..... 171**

**APPENDIX I: RECOMMENDED SPARES..... 179**

**APPENDIX J: COMBUSTION CALIBRATION (KOREA ONLY) ..... 181**

**APPENDIX K: WARRANTY ..... 185**

## **FOREWORD**

The AERCO Innovation Series Potable Water Heaters are modulating units which represent a true industry advance that meets the needs of today's energy efficiency and environmental concerns. Designed for use in any domestic water heating system, each Innovation model provides precisely-controlled potable water within  $\pm 2^{\circ}\text{F}$  of setpoint, regardless of flow rate. Innovation's compact size and varied venting capabilities allow maximum installation flexibility. The Innovation Series Heaters, with their load tracking controls modulate over a 20:1 turn down ratio to match the system demand and yield high thermal efficiencies.

Innovation Water Heaters are available in four (4) different sizes ranging from 600,000 BTU/Hr. Input to 1,350,000 BTU/Hr. Input. In addition, all Innovation Heater sizes now include Water Heater Management (WHM) software which is built in to the C-More Controllers furnished with each unit. When the heater is ordered with a Sequencing Valve (SV), up to eight (8) Innovation Water Heaters can be controlled by the WHM system utilizing RS485 Modbus protocol. All available Innovation Water Heater models are listed in the table on the following page. As this table shows, units can be ordered with Factory Mutual (FM) or Double Block and Bleed (formerly IRI) Gas Trains with or without Sequencing Valves.

When installed and operated on natural gas in accordance with this Instruction Manual, the Innovation Series Models covered herein comply with the NO<sub>x</sub> emission standards outlined in:

- South Coast Air Quality Management District (SCAQMD), Rule 1146.2
- Texas Commission on Environmental Quality (TCEQ), Title 30, Chapter 117, Rule 117.465

Whether used in singular or modular arrangements, the Innovation Heaters offer the maximum flexibility in venting with minimum installation space requirements. Innovation's advanced electronic controls offer simplified integration with today's Energy Management Systems.

For service or parts, contact your local sales representative or AERCO International, Inc.

### **IMPORTANT**

Unless otherwise specified, the descriptions and procedures provided in this Installation, Operation & Maintenance Manual apply to all Innovation Series Water Heaters.

## INNOVATION POTABLE WATER HEATER MODELS

Part Number	Description	Shipping Weight
INN600	Innovation Potable Water Heater, 600,000 BTU/HR Input, Natural Gas, FM Gas Train	1,060 lbs.
INN600SV	Innovation Potable Water Heater, 600,000 BTU/HR Input, Natural Gas, FM Gas Train with WHM Sequencing Valve	1,080 lbs.
INN600DBB	Innovation Potable Water Heater, 600,000 BTU/HR Input, Natural Gas, Double Block & Bleed (Formerly IRI) Gas Train	1,085 lbs.
INN600SVDBB	Innovation Potable Water Heater, 600,000 BTU/HR Input, Natural Gas, Double Block & Bleed (Formerly IRI) Gas Train with WHM Sequencing Valve	1,105 lbs.
INN800	Innovation Potable Water Heater, 800,000 BTU/HR Input, Natural Gas, FM Gas Train	1,080 lbs.
INN800SV	Innovation Potable Water Heater, 800,000 BTU/HR Input, Natural Gas, FM Gas Train with WHM Sequencing Valve	1,100 lbs.
INN800DBB	Innovation Potable Water Heater, 800,000 BTU/HR Input, Natural Gas, Double Block & Bleed (Formerly IRI) Gas Train	1,095 lbs.
INN800SVDBB	Innovation Potable Water Heater, 800,000 BTU/HR Input, Natural Gas, Double Block & Bleed (Formerly IRI) Gas Train with WHM Sequencing Valve	1,115 lbs.
INN1060	Innovation Potable Water Heater, 1,060,000 BTU/HR Input, Natural Gas, FM Gas Train	1,100 lbs.
INN1060SV	Innovation Potable Water Heater, 1,060,000 BTU/HR Input, Natural Gas, FM Gas Train with WHM Sequencing Valve	1,120 lbs.
INN1060DBB	Innovation Potable Water Heater, 1,060,000 BTU/HR Input, Natural Gas, Double Block & Bleed (Formerly IRI) Gas Train	1,115 lbs.
INN1060SVDBB	Innovation Potable Water Heater, 1,060,000 BTU/HR Input, Natural Gas, Double Block & Bleed (Formerly IRI) Gas Train with WHM Sequencing Valve	1,135 lbs.
INN1350	Innovation Potable Water Heater, 1,350,000 BTU/HR Input, Natural Gas, FM Gas Train	1,150 lbs.
INN1350SV	Innovation Potable Water Heater, 1,350,000 BTU/HR Input, Natural Gas, FM Gas Train with WHM Sequencing Valve	1,170 lbs.
INN1350DBB	Innovation Potable Water Heater, 1,350,000 BTU/HR Input, Natural Gas, Double Block & Bleed (Formerly IRI) Gas Train	1,165 lbs.
INN1350SVDBB	Innovation Potable Water Heater, 1,350,000 BTU/HR Input, Natural Gas, Double Block & Bleed (Formerly IRI) Gas Train with WHM Sequencing Valve	1,205 lbs.



Phrases, abbreviations and acronyms used in this manual are listed in the following Table:

***PHRASES, ABBREVIATIONS AND ACRONYMS***

<b>Phrase, Abbreviation or Acronym</b>	<b>Meaning</b>
A (Amp)	Ampere
ADDR	Address
AGND	Analog Ground
ALRM	Alarm
ASME	American Society of Mechanical Engineers
AUX	Auxiliary
BAS	Building Automation System, often used interchangeably with EMS (see below)
Baud Rate	Symbol rate, or simply the number of distinct symbol changes (signaling events) transmitted per second. It is not equal to bits per second, unless each symbol is 1 bit long.
BLDG (Bldg)	Building
CCP	Combustion Control Panel
C-More Controller (or Control Box)	A control system developed by AERCO and currently used in all Benchmark, Innovation and KC1000 Series product lines.
CO	Carbon Monoxide
COMM (Comm)	Communication
DBB	Double Block & Bleed. Used to define gas trains containing two SSOVs and a solenoid operated vent valve. Used interchangeably with IRI.
BTU	British Thermal Unit. A unit of energy approximately equal to the heat required to raise 1 pound of water 1°F.
Cal.	Calibration
CNTL	Control
DBB	Double block and Bleed (formerly IRI)
DIP	Dual In-Line Package
EMS	Energy Management System; often used interchangeably with BAS
FM	Factory Mutual. Used to define boiler gas trains.
GND	Ground
HDR	Header
HX	Heat Exchanger
Hz	Hertz (Cycles Per Second)
I.D.	Inside Diameter
IGN	Ignition
IGST Board	Ignition/Stepper Board contained in C-More Control Box
INN	Innovation Water Heater
INTLK (INTL'K)	Interlock
I/O	Input/Output
I/O Box	Input/Output (I/O) Box currently used on Benchmark, Innovation and KC1000 Series products
IP	Internet Protocol
IRI	Industrial Risk Insurers. Used to define gas trains containing two SSOVs and a solenoid operated vent valve.
ISO	Isolated
LED	Light Emitting Diode
LN	Low NOx
MA (mA)	Milliamperes
MAX (Max)	Maximum

**PHRASES, ABBREVIATIONS AND ACRONYMS - Continued**

<b>Phrase, Abbreviation or Acronym</b>	<b>Meaning</b>
MIN (Min)	
Modbus®	A serial, half-duplex data transmission protocol developed by AEG Modicon
NC (N.C.)	Normally Closed
NO (N.O.)	Normally Open
NOx	Nitrogen Oxide
NPT	National Pipe Thread
O2	Oxygen
O.D.	Outside Diameter
PMC Board	A Primary Micro-Controller (PMC) board is contained in the C-More Control Box used on all Benchmark units.
PPM	Parts Per Million
PTP	Point-to-Point (usually over RS232 networks)
REF (Ref)	Reference
RES.	Resistive
RS232 (or EIA-232)	A standard for serial, full-duplex (FDX) transmission of data based on the RS232 Standard
RS422 (or EIA-422)	A standard for serial, full-duplex (FDX) transmission of data based on the RS422 Standard
RS485 (or EIA-485)	A standard for serial, half-duplex (HDX) transmission of data based on the RS485 Standard
RTN (Rtn)	Return
SETPT (Setpt)	Setpoint Temperature
SHLD (Shld)	Shield
SSOV	Safety Shut Off Valve
SV	Sequencing Valve (Used with Water Heater Management (WHM) system)
TEMP (Temp)	Temperature
Terminating Resistor	A resistor placed at each end of a daisy-chain or multi-drop network in order to prevent reflections that may cause invalid data in the communication
VAC	Volts, Alternating Current
VDC	Volts, Direct Current
VFD	Vacuum Fluorescent Display, or Variable Frequency Drive
W	Watt
W.C.	Water Column
WHM	Water Heater Management

## CHAPTER 1 SAFETY PRECAUTIONS

### 1.1 WARNINGS & CAUTIONS

Installers and operating personnel **MUST**, at all times, observe all safety regulations. The following warnings and cautions are general and must be given the same attention as specific precautions included in these instructions. In addition to all the requirements included in this AERCO Instruction Manual, the installation of units **MUST** conform with local building codes, or, in the absence of local codes, ANSI Z223.1 (National Fuel Gas Code Publication No. NFPA-54) for gas-fired heaters and ANSI/NFPA5B for LP gas-fired heaters. Where applicable, the equipment shall be installed in accordance with the current Installation Code for Gas Burning Appliances and Equipment, CSA B149.1, and applicable Provincial regulations for the class; which should be carefully followed in all cases. Authorities having jurisdiction should be consulted before installations are made.

See pages 11 and 12 for information on installations within the Commonwealth of Massachusetts.

#### **IMPORTANT**

This Instruction Manual is an integral part of the product and must be maintained in legible condition. It must be given to the user by the installer and kept in a safe place for future reference.

#### **IMPORTANT**

Read the following restrictions prior to installing the water heater:

1. The water heater can only be used for applications where the chlorine concentrations Do Not Exceed 4 mg/L which is the Environmental Protection Agency limit for chlorine concentrations in drinking water.
2. Do Not use this heater for a pool heating application.

#### **⚠ WARNING ⚠**

**DO NOT USE MATCHES, CANDLES, FLAMES, OR OTHER SOURCES OF IGNITION TO CHECK FOR GAS LEAKS.**

#### **⚠ WARNING ⚠**

**FLUIDS UNDER PRESSURE MAY CAUSE INJURY TO PERSONNEL OR DAMAGE TO EQUIPMENT WHEN RELEASED. BE SURE TO SHUT OFF ALL INCOMING AND OUTGOING WATER SHUTOFF VALVES. CAREFULLY DECREASE ALL TRAPPED PRESSURES TO ZERO BEFORE PERFORMING MAINTENANCE.**

#### **⚠ WARNING ⚠**

**ELECTRICAL VOLTAGES UP TO 120 VAC MAY BE USED IN THIS EQUIPMENT. THEREFORE THE COVER ON THE UNIT'S POWER BOX (LOCATED BEHIND THE FRONT PANEL DOOR) MUST BE INSTALLED AT ALL TIMES, EXCEPT DURING MAINTENANCE AND SERVICING.**

#### **⚠ WARNING ⚠**

**A DOUBLE-POLE SWITCH MUST BE INSTALLED ON THE ELECTRICAL SUPPLY LINE OF THE UNIT. THE SWITCH MUST BE INSTALLED IN AN EASILY ACCESSIBLE POSITION TO QUICKLY AND SAFELY DISCONNECT ELECTRICAL SERVICE. DO NOT AFFIX SWITCH TO UNIT SHEET METAL ENCLOSURES.**

**⚠ CAUTION ⚠**

Must be observed to prevent equipment damage or loss of operating effectiveness.

**⚠ CAUTION ⚠**

Many soaps used for gas pipe leak testing are corrosive to metals. The piping must be rinsed thoroughly with clean water after leak checks have been completed.

**⚠ CAUTION ⚠**

DO NOT use this heater if any part has been under water. Call a qualified service technician to inspect and replace any part that has been under water.

## 1.2 EMERGENCY SHUTDOWN

If overheating occurs or the gas supply fails to shut off, close the manual gas shutoff valve (Figure 1-1) located external to the unit.

### **IMPORTANT**

The Installer must identify and indicate the location of the emergency shutdown manual gas valve to operating personnel.

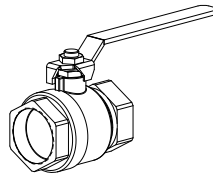

MANUAL GAS SHUTOFF VALVE

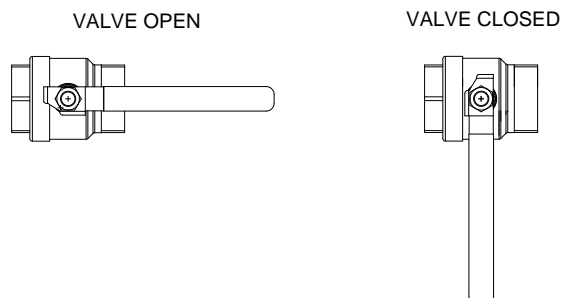

**Figure 1-1. Manual Gas Shutoff Valve**

## 1.3 PROLONGED SHUTDOWN

After prolonged shutdown, it is recommended that the startup procedures in Chapter 4 and the safety device test procedures in Chapter 6 of this manual be performed, to verify all system-operating parameters. If there is an emergency, turn off the electrical power supply to the AERCO heater and close the manual gas valve located upstream the unit. The installer must identify the emergency shut-off device.

### **IMPORTANT – FOR MASSACHUSETTS INSTALLATIONS**

Water heater Installations within the Commonwealth of Massachusetts must conform to the following requirements:

- Heater must be installed by a plumber or a gas fitter who is licensed within the Commonwealth of Massachusetts.
- Prior to unit operation, the complete gas train and all connections must be leak tested using a non-corrosive soap.
- The vent termination must be located a minimum of 4 feet above grade level. If side-wall venting is used, the installation must conform to the following requirements **extracted from 248 CMR 5.08 (2)**:

(a) For all side wall horizontally vented gas fueled equipment installed in every dwelling, building or structure used in whole or in part for residential purposes, including those owned or operated by the Commonwealth and where the side wall exhaust vent termination is less than seven (7) feet above finished grade in the area of the venting, including but not limited to decks and porches, the following requirements shall be satisfied:

1. INSTALLATION OF CARBON MONOXIDE DETECTORS. At the time of installation of the side wall horizontal vented gas fueled equipment, the installing plumber or gasfitter shall observe that a hard wired carbon monoxide detector with an alarm and battery back-up is installed on the floor level where the gas equipment is to be installed. In addition, the installing plumber or gasfitter shall observe that a battery operated or hard wired carbon monoxide detector with an alarm is installed on each additional level of the dwelling, building or structure served by the side wall horizontal vented gas fueled equipment. It shall be the responsibility of the property owner to secure the services of qualified licensed professionals for the installation of hard wired carbon monoxide detectors.

a. In the event that the side wall horizontally vented gas fueled equipment is installed in a crawl space or an attic, the hard wired carbon monoxide detector with alarm and battery back-up may be installed on the next adjacent floor level.

b. In the event that the requirements of this subdivision can not be met at the time of completion of installation, the owner shall have a period of thirty (30) days to comply with the above requirements; provided, however, that during said thirty (30) day period, a battery operated carbon monoxide detector with an alarm shall be installed.

2. APPROVED CARBON MONOXIDE DETECTORS. Each carbon monoxide detector as required in accordance with the above provisions shall comply with NFPA 720 and be ANSI/UL 2034 listed and IAS certified.

3. SIGNAGE. A metal or plastic identification plate shall be permanently mounted to the exterior of the building at a minimum height of eight (8) feet above grade directly in line with the exhaust vent terminal for the horizontally vented gas fueled heating appliance or equipment. The sign shall read, in print size no less than one-half (1/2) inch in size, "**GAS VENT DIRECTLY BELOW. KEEP CLEAR OF ALL OBSTRUCTIONS**".

4. INSPECTION. The state or local gas inspector of the side wall horizontally vented gas fueled equipment shall not approve the installation unless, upon inspection, the inspector observes carbon monoxide detectors and signage installed in accordance with the provisions of 248 CMR 5.08(2)(a)1 through 4.

(b) EXEMPTIONS: The following equipment is exempt from 248 CMR 5.08(2)(a)1 through 4:

1. The equipment listed in Chapter 10 entitled "Equipment Not Required To Be Vented" in the most current edition of NFPA 54 as adopted by the Board; and
2. Product Approved side wall horizontally vented gas fueled equipment installed in a room or structure separate from the dwelling, building or structure used in whole or in part for residential purposes.

(c) MANUFACTURER REQUIREMENTS - GAS EQUIPMENT VENTING SYSTEM PROVIDED. When the manufacturer of Product Approved side wall horizontally vented gas equipment provides a venting system design or venting system components with the equipment, the instructions provided by the manufacturer for installation of the equipment and the venting system shall include:

1. Detailed instructions for the installation of the venting system design or the venting system components; and
2. A complete parts list for the venting system design or venting system.

(d) MANUFACTURER REQUIREMENTS - GAS EQUIPMENT VENTING SYSTEM NOT PROVIDED. When the manufacturer of a Product Approved side wall horizontally vented gas fueled equipment does not provide the parts for venting the flue gases, but identifies "special venting systems", the following requirements shall be satisfied by the manufacturer:

1. The referenced "special venting system" instructions shall be included with the appliance or equipment installation instructions; and
2. The "special venting systems" shall be Product Approved by the Board, and the instructions for that system shall include a parts list and detailed installation instructions.

(e) A copy of all installation instructions for all Product Approved side wall horizontally vented gas fueled equipment, all venting instructions, all parts lists for venting instructions, and/or all venting design instructions shall remain with the appliance or equipment at the completion of the installation.

---

**[End of Extracted Information From 248 CMR 5.08 (2)]**

## CHAPTER 2 INSTALLATION

### 2.1 INTRODUCTION

This Chapter provides the descriptions and procedures necessary to unpack, inspect and install AERCO Innovation Water Heater Models INN600, INN800 and INN1060 and INN1350.

### 2.2 RECEIVING THE UNIT

Each Innovation Water Heating System is shipped as a single crated unit. The shipping weight is approximately 1200 pounds. The unit must be moved with the proper rigging equipment for safety and to avoid equipment damage. The unit should be completely inspected for evidence of shipping damage and shipment completeness at the time of receipt from the carrier and before the bill of lading is signed.

#### NOTE:

AERCO is not responsible for lost or damaged freight. Each unit has a Tip-N-Tell indicator on the outside of the crate. This indicates if the unit has been turned on its side during shipment. If the Tip-N-Tell indicator is tripped, do not sign for the shipment. Note the information on the carrier's paperwork and request a freight claim and inspection by a claims adjuster before proceeding. Any other visual damage to the packaging materials should also be made clear to the delivering carrier.

### 2.3 UNPACKING

Carefully unpack the unit taking care not to damage the unit enclosure when cutting away packaging materials

After unpacking, a close inspection of the unit should be made to ensure that there is no evidence of damage not indicated by the Tip-N-Tell indicator. The freight carrier should be notified immediately if any damage is detected.

The following accessories come standard with each unit and are either packed separately within the unit's shipping container or are factory installed on the unit:

- Pressure/Temperature Gauge
- Spare Spark Igniter-Injector
- Spare Flame Detector
- ASME Pressure Relief Valve
- Condensate Drain Trap
- 1" Gas Supply Shutoff Valve

If the Innovation Water Heater is equipped for use with the AERCO Water Heater Management (WHM) system, an actuator-controlled ball valve will also be included with the unit.

When optional accessories are ordered, they may be packed within the unit's shipping container, factory installed on the unit, or packed and shipped in a separate container. Any standard or optional accessories shipped loose should be identified and stored in a safe place until ready for installation or use.

### 2.4 SITE PREPARATION

Ensure that the site selected for installation of the Innovation Water Heater includes:

- Access to AC Input Power at 120 VAC, Single-Phase, 60 Hz @ 20 Amps.
- Access to Natural Gas line at a minimum pressure of 4 inches W.C.

### 2.4.1 Installation Clearances

All Innovation Models are packaged in enclosures having identical exterior dimensions. The unit must be installed with the prescribed clearances for service as shown in Figure 2-1 (shown with optional Sequencing Valve). The minimum clearance dimensions, required by AERCO, are listed below. However, if Local Building Codes require additional clearances, these codes shall supersede AERCO's requirements. Minimum acceptable clearances required are as follows:

- Sides: 24 inches
- Front : 24 inches
- Rear:30 inches
- Top: 18 inches

All gas piping, water piping and electrical conduit or cable must be arranged so that they do not interfere with the removal of any panels, or inhibit service or maintenance of the unit.

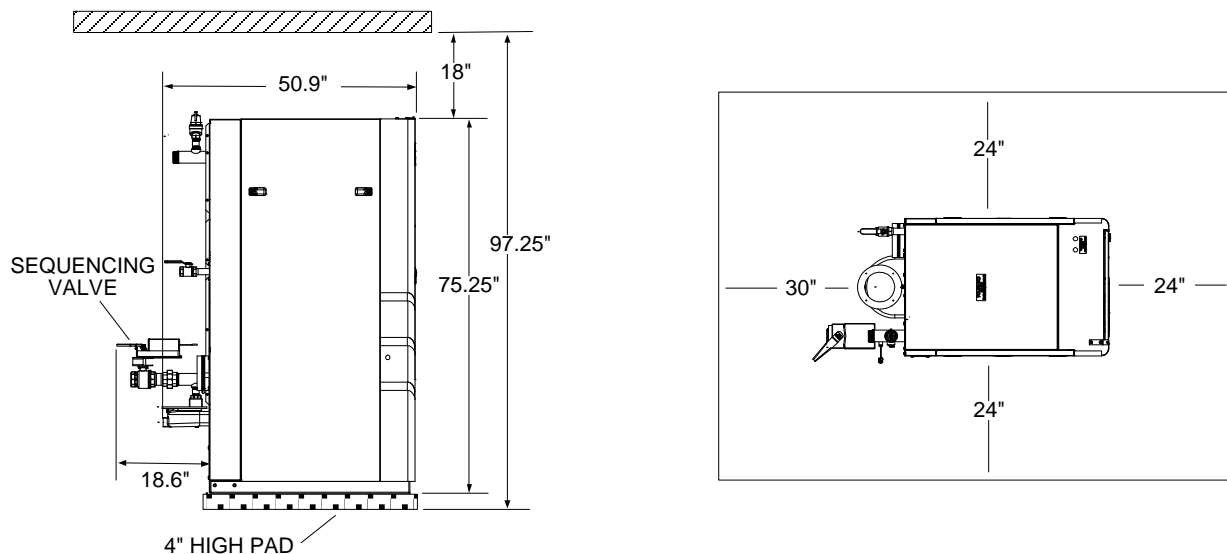

**Figure 2-1 Innovation Water Heater Clearances**

**⚠ WARNING ⚠**

KEEP THE UNIT AREA CLEAR AND FREE FROM ALL COMBUSTIBLE MATERIALS AND FLAMMABLE VAPORS OR LIQUIDS.

**⚠ CAUTION ⚠**

While packaged in the shipping container, the unit must be moved by pallet jack or forklift from the FRONT ONLY.

**FOR MASSACHUSETTS ONLY:**

For Massachusetts installations, the unit must be installed by a plumber or gas-fitter who is licensed within the Commonwealth of Massachusetts. In addition, the installation must comply with all requirements specified in Chapter 1 (Safety Precautions), pages 11 and 12.



### 2.4.2 Setting the Unit

The unit must be installed on a 4 inch to 6 inch housekeeping pad to ensure proper condensate drainage. If anchoring the unit, refer to the dimensional drawings in Appendix F for anchor locations. Two lifting lugs are provided with the unit and are wire-tied to the top of the heat exchanger. The top sheet metal cover of the unit must first be removed and the lifting lugs must be installed as shown in Figure 2-2. **USE THESE TWO LUGS TO LIFT AND MOVE THE UNIT.** Remove the top panel from the unit to provide access to the lifting lugs. Remove the four (4) lag screws securing the unit to the shipping skid. Lift the unit off the shipping skid and position it on the 4 inch to 6 inch housekeeping concrete pad (required) in the desired location.

In multiple unit installations, it is important to plan the position of each unit in advance. Sufficient space for piping connections and future service/maintenance requirements must also be taken into consideration. All piping must include ample provisions for expansion.

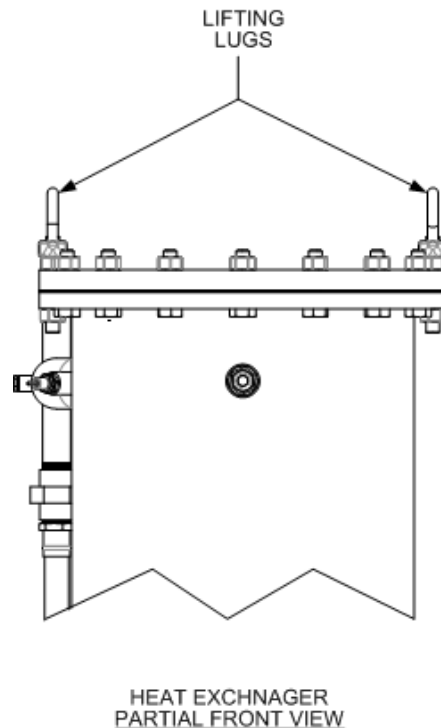

**Figure 2-2 Partial Top View Showing Installed Lifting Lugs**

#### **IMPORTANT**

If the Innovation Water Heater is equipped for use with the C-More Water Heater Management (WHM) system an actuator-controlled ball valve will be included with the shipment. If the valve is not already installed on the water inlet of the unit, refer to paragraph 2.5.1 for installation instructions prior to connecting inlet piping.

### 2.5 WATER INLET AND OUTLET PIPING

The locations of the 2" NPT cold water inlet and hot water outlet piping connections are shown in Figure 2-3. Flow rates through the unit are limited to 30 gpm continuous and 40 gpm intermittent.

Shut-off valves and union connections must be installed in the inlet and outlet lines for maintenance. The use of dielectric unions is recommended.

**NOTE:**

All piping must be arranged so that it does not interfere with removal of any covers, inhibit service or maintenance, or prevent access between the unit and walls, or another unit.

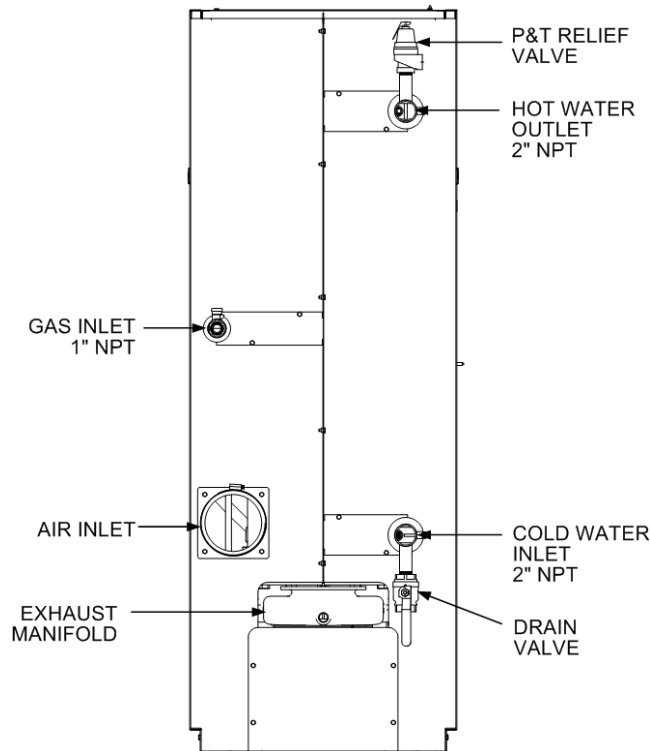

**Figure 2-3. Water Inlet & Outlet Locations**

**2.5.1 WHM Actuator-Controlled Ball Valve Installation**

If the Innovation Water Heater was ordered for use with the C-More Water Heater Management (WHM) system and the actuator-controlled ball valve is not already installed on the unit (Figure 2-3A), it will be packed separately within the shipping container. If installation is required, proceed as follows:

**WHM Ball Valve Installation**

1. Remove the ball valve from its stowed location within the shipping container.
2. Attached the valve to the cold water inlet of the unit using the pipe union and nipple provided.
3. Ensure that the valve is positioned with the actuator enclosure position as shown in Figure 2-3A.
4. AERCO recommends that another pipe nipple and union be attached to the valve inlet prior to connecting the cold water supply piping.
5. Tighten all pipe connections after the valve is properly positioned.
6. Connect the 3-pin Molex connector on the valve to the mating connector on the Innovation harness at the rear of the unit.
7. This completes the actuator-controlled ball valve installation.

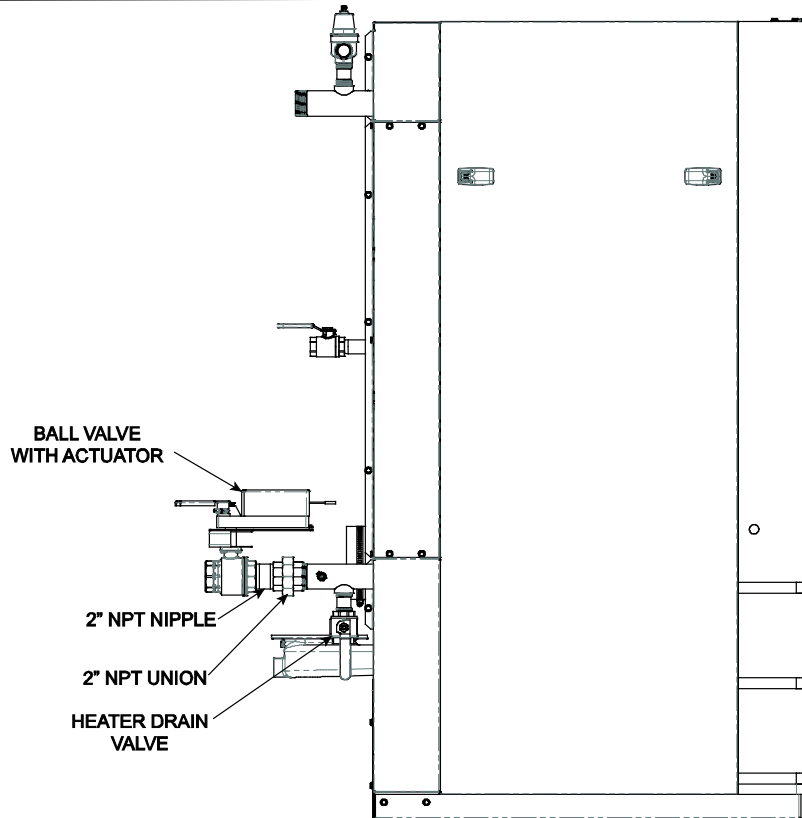

**Figure 2-3A. Innovation Water Heater Equipped With Sequencing Valve**

## 2.6 TEST HOSE BIB CONNECTION

A Test Hose Bib connection, upstream of the shut off valve on the hot water outlet, is required for startup and testing (Figure 2-4). The pipe diameter should be a minimum of 3/4". The Test Hose **Bib** cannot be omitted.

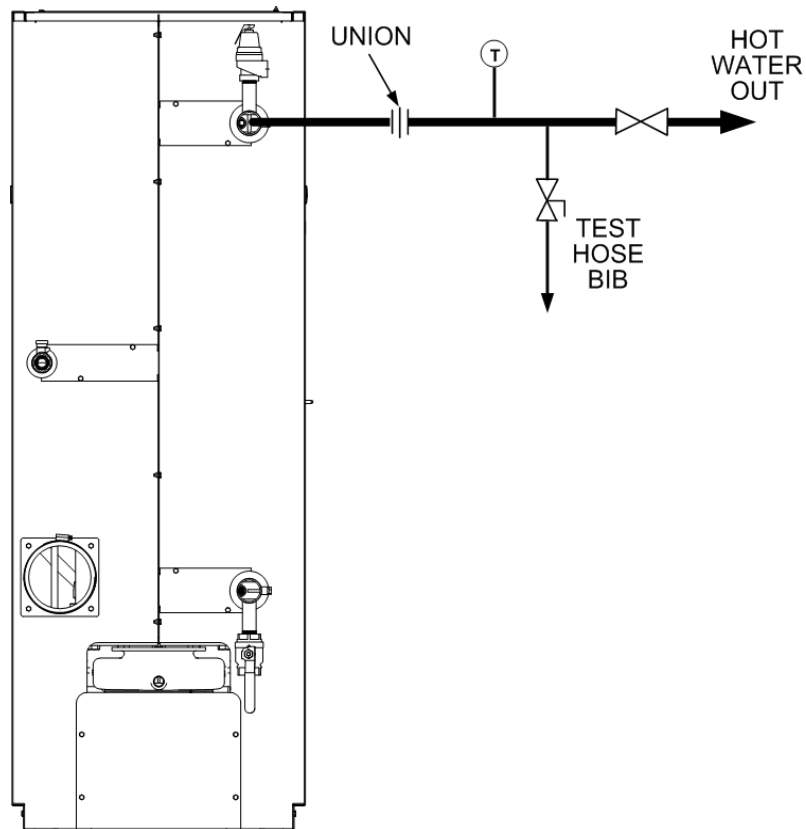

**Figure 2-4. Test Hose Bib Location**

## 2.7 SYSTEM RECIRCULATION LOOP

The System Recirculation Loop Assembly is located inside the unit enclosure at the rear of the unit. In order to access this assembly, the right rear middle panel must be removed. Refer to Figure 2-5. This assembly contains a recirculator pump which connects between the upper hot water outlet and lower cold water inlet of the unit's heat exchanger. The purpose of this loop is to provide feed-forward (FFWD) temperature control by mixing a portion of the hot water outlet with the cold water inlet of the unit. Temperature sensors located in the hot water outlet and cold water inlet provide temperature data to the C-More Control System. The Control System utilizes this data to modulate the fire rate (Air/Fuel Valve position) to precisely maintain the hot water outlet temperature at the selected setpoint temperature.

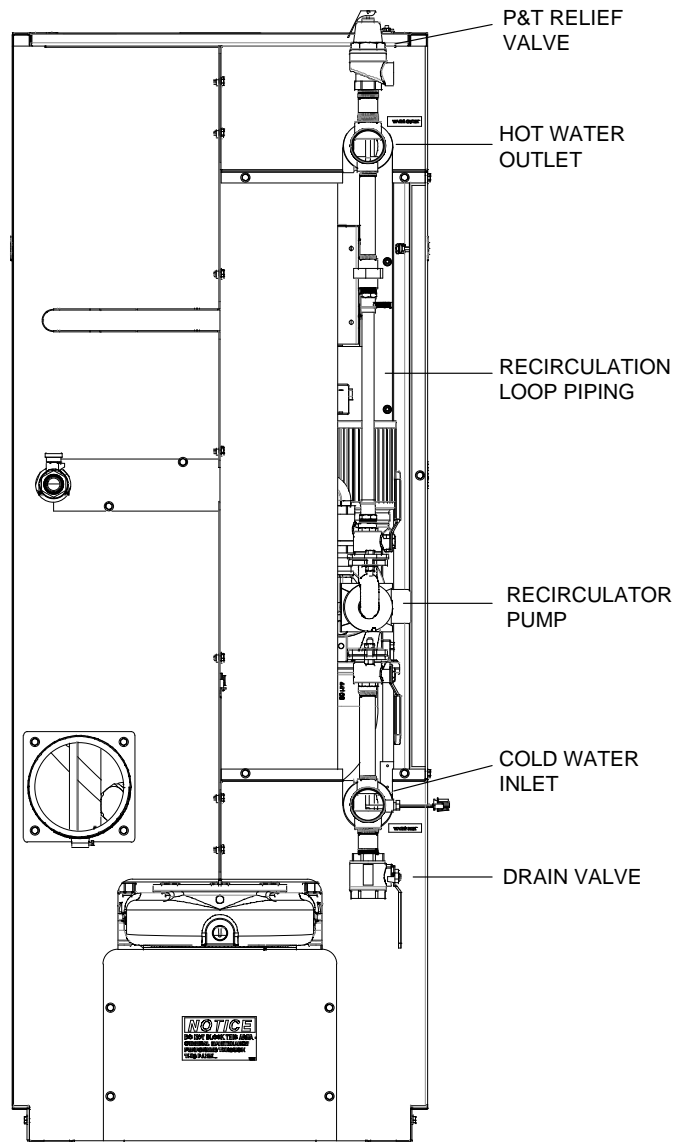

REAR VIEW WITH RIGHT CENTER PANEL REMOVED

**Figure 2-5. Recirculation Loop**

**NOTE:**

The maximum working pressure for installations within the Province of Alberta is 87 psig. Therefore, a pressure & temperature relief valve with a setting of 75 psig/210°F is supplied with Alberta shipments. See AP-A-863 in Appendix E.

**2.8 PRESSURE & TEMPERATURE RELIEF VALVE INSTALLATION**

An ASME rated Pressure & Temperature (P&T) Relief Valve is supplied with each Innovation Water Heater. With the exception of Alberta installations (see above Note), the valve setpoint is 150 psig/210°F. The P&T Relief Valve is installed on the hot water outlet at the top of the Recirculation Loop Assembly as shown in Figure 2-5. A suitable pipe joint compound should be used on the threaded connections. Any excess should be wiped off to avoid getting any into the valve body. The relief valve should be piped to within 12 inches of the floor to prevent injury in the event of a discharge. The relief outlet piping must be equal to the outlet size of the relief valve without reduction. No valves, restrictions, or other blockages are allowed in the discharge line. In multiple unit installations the discharge lines must not be manifolded together. Each must be individually run to a suitable discharge location.

**2.9 CONDENSATE DRAIN & PIPING**

The Innovation Water Heater is designed to condense water vapor from the flue products. Therefore, the installation must have provisions for suitable condensate drainage or collection.

The condensate drain port, is located on the exhaust manifold at the rear of the unit (Figure 2-6). This drain port must be connected to the Condensate Trap (part no. 24060) which is packed separately within the unit's shipping container. The Condensate Trap inlet and outlet connections contain tapped 3/4" NPT ports.

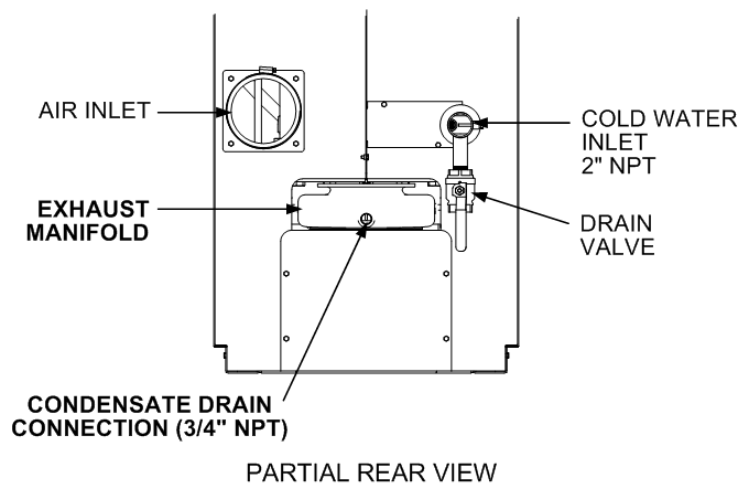

**Figure 2-6. Condensate Drain Connection Location**

A sample Condensate Trap installation is shown in Figure 2-7. However, the actual installation details for the trap will vary depending on the available clearances, housekeeping pad height/ dimensions and other prevailing conditions at the site. the following general guidelines must be observed to ensure proper condensate drainage:

- The condensate trap inlet (Figure 2-6) must be level with, or lower than the exhaust manifold drain port.
- The base of the condensate trap must be supported to ensure that it is level (horizontal).
- The trap must be removable for routine maintenance. AERCO recommends that a union be utilized between the exhaust manifold condensate drain port and the trap inlet port.

While observing the above guidelines, install the condensate trap as follows:

### Condensate Trap Installation

1. Connect the condensate trap inlet to the exhaust manifold drain connection using the appropriate piping components (nipples, reducers, elbows, etc.) for the heater installation site
2. At the condensate trap outlet, install a 3/4" NPT nipple.
3. Connect a length of 1" I.D polypropylene hose to the trap outlet and secure with a hose clamp.
4. Route the hose on the trap outlet to a nearby floor drain.

If a floor drain is not available, a condensate pump can be used to remove the condensate to drain. The maximum condensate flow rate is 20 GPH. The condensate drain trap, associated fittings and drain line must be removable for routine maintenance.

### NOTE:

Two different styles of condensate traps are currently in use. The functions and connections provided by each style are identical however the two styles look slightly different. Figure 2-7 shows the two styles that are currently in use.

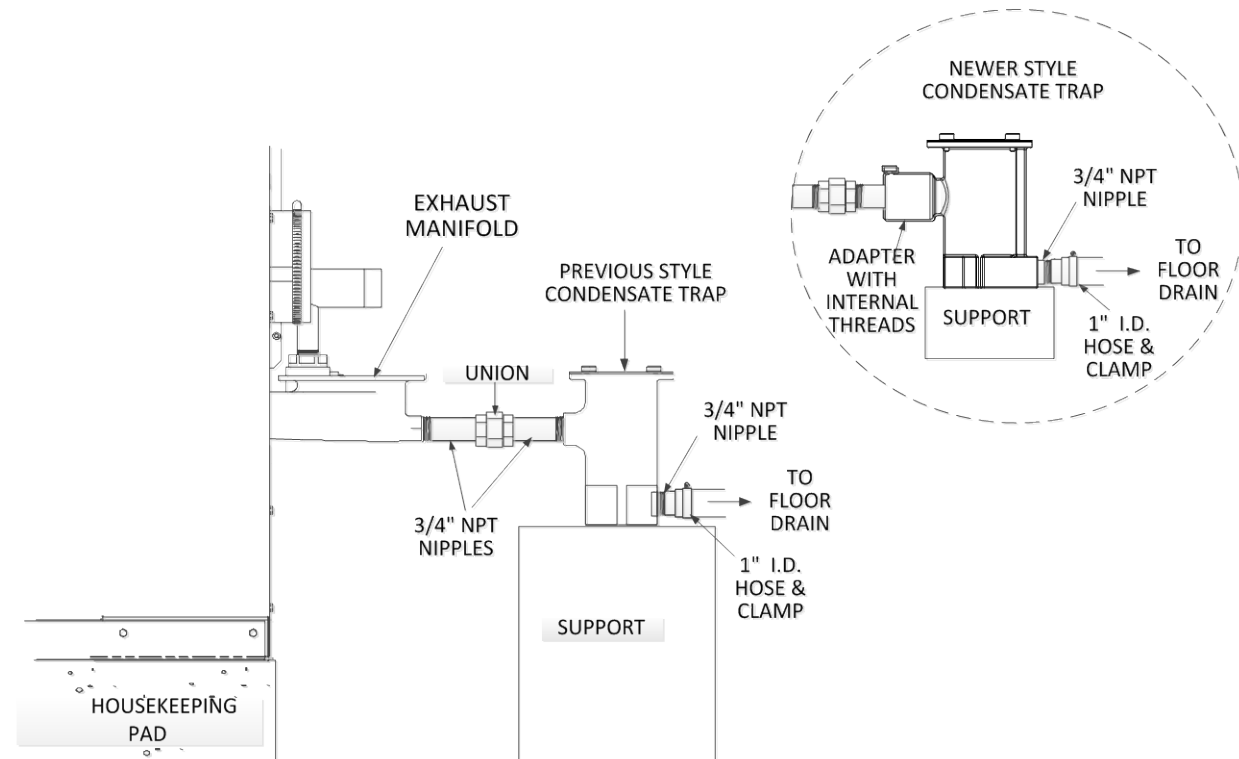

**Figure 2-7. Sample Condensate Trap Installation**

## 2.10 GAS SUPPLY PIPING

The AERCO Innovation Gas Components and Supply Design Guide, GF-5030 must be consulted prior to designing or installing any gas supply piping.

### **WARNING**

NEVER USE MATCHES, CANDLES, FLAMES OR OTHER SOURCES OF IGNITION TO CHECK FOR GAS LEAKS.

### **CAUTION**

Many soaps used for gas pipe leak testing are corrosive to metals. Therefore, piping must be rinsed thoroughly with clean water after leak checks have been completed.

### **NOTE**

All gas piping must be arranged so that it does not interfere with removal of any covers, inhibit service/maintenance, or restrict access between the unit and walls, or another unit.

Innovation units contain a 1 inch NPT gas inlet connection on the rear of the unit as shown in Figure 2-3.

Prior to installation, all pipes should be de-burred and internally cleared of any scale, metal chips or other foreign particles. Do Not install any flexible connectors or unapproved gas fittings. Piping must be supported from the floor, ceiling or walls only and must not be supported by the unit.

A suitable piping compound, approved for use with natural gas, should be used. Any excess must be wiped off to prevent clogging of components.

To avoid unit damage when pressure testing gas piping, isolate the unit from the gas supply piping. At no time should the gas pressure applied to the unit exceed 14" W.C.. Leak test all external piping thoroughly using a soap and water solution or suitable equivalent. The gas piping used must meet all applicable codes.

### 2.10.1 Gas Supply Specifications.

The gas supply input specifications to the unit for Natural Gas are as follows:

- The maximum static pressure to the unit must not exceed 14" W.C. The gas supply pressure to the unit must be of sufficient capacity to provide 1060 cfh while maintaining the gas pressure at 7 inches W.C. for FM gas trains.

### 2.10.2 Manual Gas Shutoff Valve

A manual shut-off valve must be installed in the gas supply line upstream of the Heater as shown in Figure 2-8. Maximum allowable gas pressure to the Heater is 14" W.C.

### **NOTE**

Paragraph 2.10.3 applies only to water heater installations within the Commonwealth of Massachusetts.



### 2.10.3 External Gas Supply Regulator

For Massachusetts installations, a mandatory external gas supply regulator must be positioned as shown in Figure 2-6. The gas supply regulator must be properly vented to outdoors. Consult the local gas utility for detailed requirements concerning venting of the the supply gas regulator.

#### NOTE

The external regulator must be capable of regulating 40,000 – 1,060,000 BTU/HR of natural gas while maintaining a gas pressure of 7.0" W.C. to the unit.

#### **⚠ CAUTION ⚠**

A lock-up style regulator **MUST** be used when gas supply pressure will exceed 14" W.C.

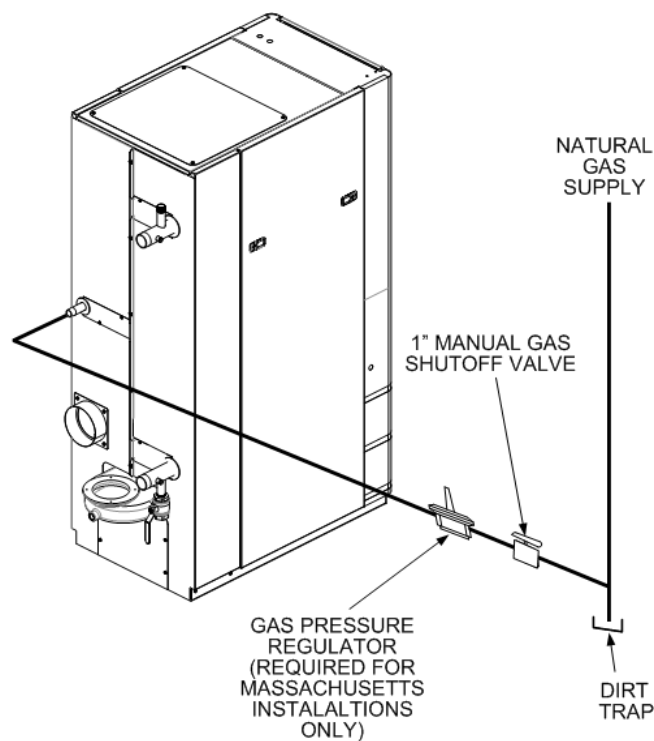

**Figure 2-8. Manual Gas Shut-Off Valve Location**

### 2.11 AC ELECTRICAL POWER WIRING

The AERCO Innovation Electrical Power Wiring Guide, GF-5060, must be consulted prior to connecting any AC power wiring to the unit. External AC power connections are made to the unit inside the Power Box on the front panel of the unit. Remove the front door of the unit to access the Power Box mounted directly above the Control Box. Loosen the four Power Box cover screws and remove cover to access the AC terminal connections inside the Power Box (Figure 2-9).

#### NOTE

All electrical conduit and hardware must be installed so that it does not interfere with the removal of any unit covers, inhibit service/maintenance, or prevent access between the unit and walls or another unit.

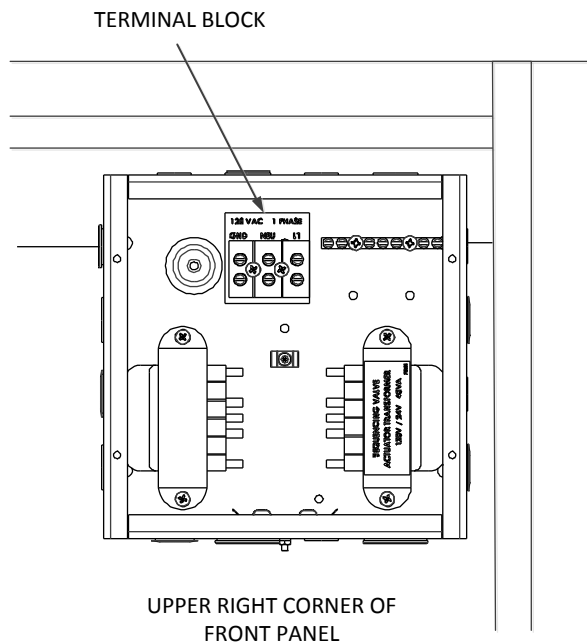

**Figure 2-9. Power Box With Cover Removed**

### 2.11.1 Electrical Power Requirements

The AERCO Innovation Heater accepts 120 VAC, single-phase, 60 Hz @ 20A. The Power Box contains a terminal block as shown in Figure 2-8. In addition, a wiring diagram showing the required AC power connections is provided on the front cover of the Power Box.

Each unit must be connected to a dedicated electrical circuit. NO OTHER DEVICES SHOULD BE ON THE SAME ELECTRICAL CIRCUIT AS THE HEATER.

A double-pole switch must be installed on the electrical supply line in an easily accessible location to quickly and safely disconnect electrical service. DO NOT attach the switch to sheet metal enclosures of the unit.

After placing the unit in service, the ignition safety shutoff device must be tested. If an external electrical power source is used, the installed boiler must be electrically bonded to ground in accordance with the requirements of the authority having jurisdiction. In the absence of such requirements, the installation shall conform to National Electrical Code (NEC), ANSI/NFPA 70 and/or the Canadian Electrical Code (CEC) Part I, CSA C22.1 Electrical Code.

For electrical power wiring diagrams, see the AERCO Innovation Electrical Power Wiring Guide, (GF-5060).

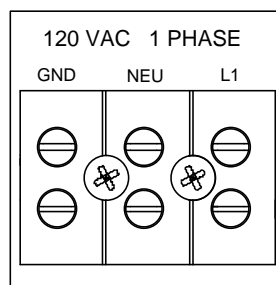
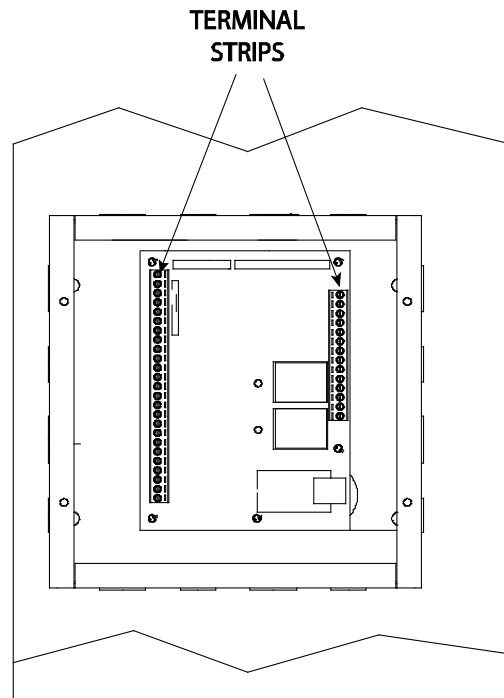

**Figure 2-10. AC Terminal Block Configurations**

## 2.12 FIELD CONTROL WIRING

Each unit is fully wired from the factory with an internal operating control system. No field control wiring is required for normal operation. However, the C-More control system used with all Innovation Heaters does allow for some control and monitoring features. Wiring connections for these features are made in the Input/Output (I/O) Box. The I/O Box is located on the upper-left portion of the unit front panel (Figure 2-11) behind the removable front panel door. To access the I/O Box terminal strips shown in Figure 2-11, loosen the four cover screws and remove the cover. All field wiring is installed from the rear of the panel by routing the wires through one of the four bushings provided.

Refer to the wiring diagram provided on the cover of the I/O Box (Figure 2-12) when making all wiring connections.

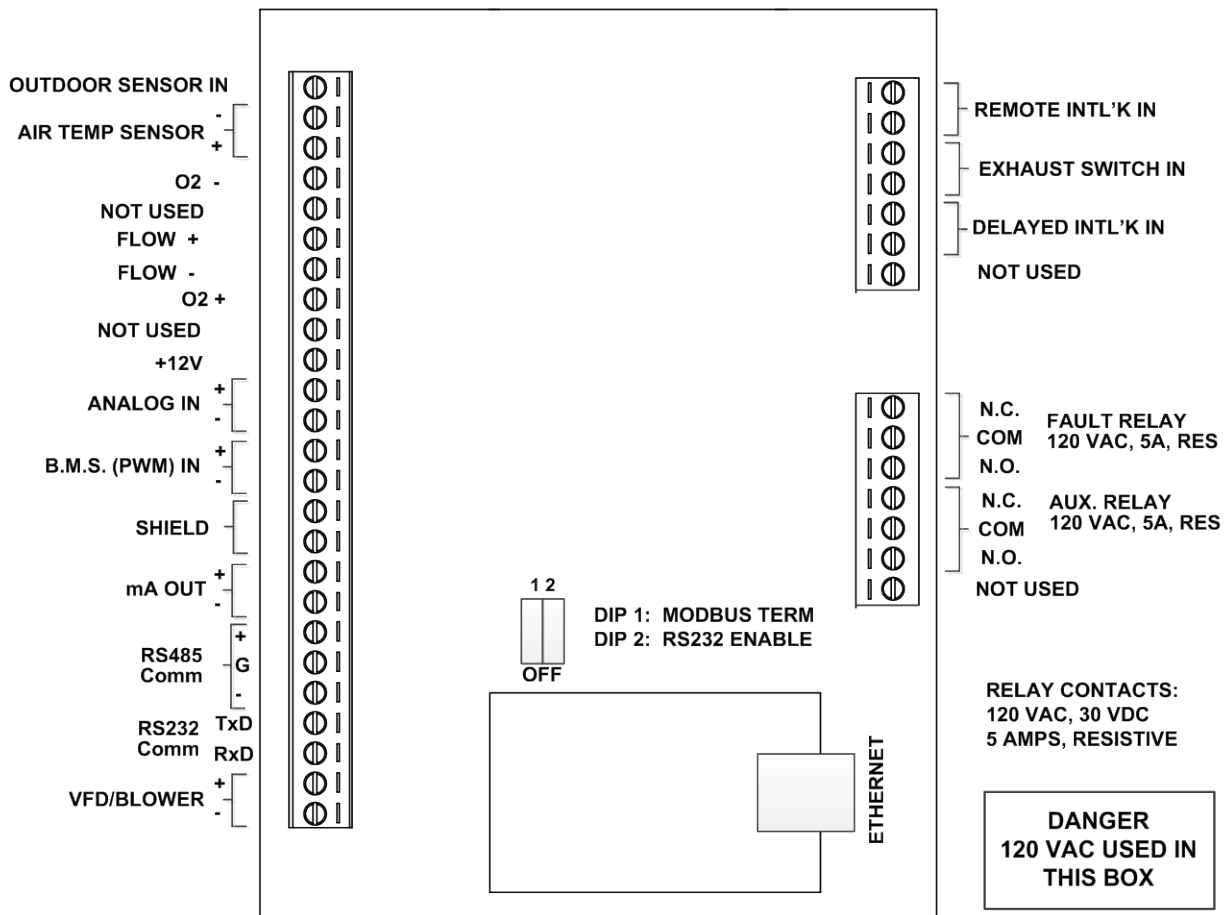

**Figure 2-11. Input/Output (I/O) Box Location**

Since identical I/O Boxes are used with both AERCO gas-fired boilers and water heaters, some of the input and output connections apply only to boilers while others are common to both boilers and heaters. These I/O Box connections are noted in the following paragraphs.

### **⚠ CAUTION ⚠**

DO NOT make any connections to the I/O Box terminals labeled “NOT USED”. Attempting to do so may cause equipment damage.



**Figure 2-12. I/O Box Terminal Strips**

### 2.12.1 OUTDOOR SENSOR IN

Not Applicable to Water Heaters.

### 2.12.2 AIR TEMP SENSOR

The AIR TEMP SENSOR terminals can be used to add an additional temperature sensor for monitoring purposes. This input is always enabled and is a view only input that can be seen in the operating menu. The sensor must be wired to the AIR TEMP SENSOR - and + terminals and must be similar to AERCO BALCO wire sensor P/N 12449. A resistance chart for this sensor is located in APPENDIX C.

### 2.12.3 O2 Sensor Terminals

The terminals labeled O2 – and O2 + are not currently used for Innovation Water Heaters.

### 2.12.4 Flow +/Flow –

These terminals are not currently used for Innovation Water Heaters.

### 2.12.5 ANALOG IN

The ANALOG IN + and – terminals are used when an external signal is supplied to change the setpoint (Remote Setpoint Mode) of the heater.

Either a 4 to 20 mA / 1 to 5 VDC or a 0 to 20 mA / 0 to 5 VDC signal may be used to vary the setpoint or air/fuel valve position. The factory default setting is for 4 to 20 mA / 1 to 5 VDC, however this may be changed to 0 to 20 mA / 0 to 5 VDC using the Configuration Menu described in Chapter 3.

If voltage rather than current is selected as the drive signal, a DIP switch must be set on the PMC Board located inside the C-More Control Box. Refer to Appendix D in C-More Manual GF-112 for information on setting DIP switches.

All supplied signals must be floating (ungrounded) signals. Connections between the source and the Heater's I/O Box must be made using twisted shielded pair of 18–22 AWG wire such as Belden 9841 (see Figure 2-12). Polarity must be maintained and the shield must be connected only at the source end and must be left floating (not connected) at the Heater's I/O Box.

Whether using voltage or current for the drive signal, they are linearly mapped to a 40°F to 240°F setpoint or a 0% to 100% air/fuel valve position. No scaling for these signals is provided

### **2.12.6 B.M.S. (PWM) IN**

Not Applicable to Water Heaters

### **2.12.7 SHIELD**

The SHIELD terminals are used to terminate any shields used on sensor wires connected to the unit. Only shields must be connected to these terminals.

### **2.12.8 mA OUT**

These terminals provide a 4 to 20 mA output which is primarily used when multiple Innovation Heaters are being controlled by the C-More Water Heater Management (WHM) system. When the WHM is set up and enabled, these terminals provide control signals to open or close the sequencing inlet valve associated with each heater based on the Domestic Hot Water (DHW) load. When the WHM system is not being utilized, these terminals can be used to monitor setpoint temperature, outlet temperature or air/fuel valve position.

### **2.12.9 RS485 Comm**

The RS485 communication terminals are used when the Innovation water heaters are being controlled by an Energy Management System (EMS) or the C-More Water Heater Management (WHM) system using Modbus (RS485) communication. The WHM software required to control up to 8 AERCO Innovation Water Heaters is included in the C-More Control System used with each Innovation unit.

### **2.12.10 RS232 Comm (TxD/RxD)**

The RS232 communication terminals (TxD, RxD) are enabled by setting DIP switch 2 (DIP2) on the I/O Board to RS232 ENABLE position. When enabled these RS232 terminals permit a laptop computer or other suitable terminal to be connected to the unit. This RS232 communication feature permits viewing or changing of control panel menu options. In addition, it provides access to data logs showing: Event Time Line, Fault Log and Sensor Log displays.

### **2.12.11 VFD/Blower**

These terminals send an analog signal to control the blower speed.

### **2.12.12 INTERLOCKS**

The unit offers two interlock circuits for interfacing with Energy Management Systems and auxiliary equipment such as pumps or louvers or other accessories. These interlocks are called the Remote Interlock and Delayed Interlock (Figure 2-12). The wiring terminals for these interlocks are located inside the I/O Box on the left side of the unit. The I/O Box cover contains a wiring diagram which shows the terminal strip locations for these interlocks (REMOTE INTL'K IN and DELAYED INTL'K IN). Both interlocks, described below, are factory wired in the closed position.

**NOTE:**

Both the Remote Interlock and Delayed Interlock must be in the closed position for the unit to fire.

**2.12.12.1 REMOTE INTERLOCK IN**

The remote interlock circuit is provided to remotely start (enable) and stop (disable) the unit if desired. The circuit is labeled REMOTE INTL'K IN and is located inside the I/O Box on the left side of the unit. The circuit is 24 VAC and comes factory pre-wired closed (jumped).

**2.12.12.2 DELAYED INTERLOCK IN**

The delayed interlock is typically used in conjunction with the auxiliary relay described in paragraph 2.12.10. This interlock circuit is located in the purge section of the start string. It can be connected to the proving device (end switch, flow switch etc.) of an auxiliary piece of equipment started by the unit's auxiliary relay. The delayed interlock must be closed for the heater to fire. If the delayed interlock is connected to a proving device that requires time to close (make), a time delay (Aux Start On Dly) that holds the start sequence of the unit long enough for a proving switch to make (close) can be programmed.

Should the proving switch not prove within the programmed time frame, the unit will shut down. The Aux Start On Dly can be programmed from 0 to 120 seconds. This option is located in the Configuration Menu (Chapter 3).

**2.12.13 FAULT RELAY**

The fault relay is a single pole double throw (SPDT) relay having a normally open and normally closed set of relay contacts that are rated for 5 amps at 120 VAC and 5 amps at 30 VDC. The relay energizes when any fault condition occurs and remains energized until the fault is cleared and the **CLEAR** button is depressed. The fault relay connections are shown in Figure 2-12.

**2.12.14 AUXILIARY (AUX) RELAY CONTACTS**

Each unit is equipped with a single pole double throw (SPDT) auxiliary relay that is energized when there is a demand for heat and de-energized after the demand for heat is satisfied. The relay is provided for the control of auxiliary equipment, such as pumps and louvers, or can be used as a unit status indicator (firing or not firing). Its contacts are rated for 120 VAC @ 5 amps. Refer to Figure 2-12 to locate the AUX RELAY terminals for wiring connections.

**2.13 FLUE GAS VENT INSTALLATION**

AERCO Gas Fired Venting and Combustion Air Guide, GF-5050 must be consulted before any flue or combustion air venting is designed or installed. Suitable, U/L approved, positive pressure, watertight vent materials **MUST** be used for safety and UL certification. Because the unit is capable of discharging low temperature exhaust gases, the flue must be pitched back towards the unit a minimum of 1/4" per foot to avoid any condensate pooling and to allow for proper drainage.

While there is a positive flue pressure during operation, the combined pressure drop of vent and combustion air systems must not exceed 140 equivalent feet of 1.9" W.C. Fittings as well as pipe lengths must be calculated as part of the equivalent length. For a natural draft installation the draft must not exceed - 0.10" W.C. These factors must be planned into the vent installation. If the maximum allowable equivalent lengths of piping are exceeded, the unit will not operate properly or reliably.

For Massachusetts installations, the Heatfab Division of the Selkirk Corporation provides vent systems which conform to all applicable requirements for installations within the Commonwealth of Massachusetts. Contact information for this supplier is as follows:

Selkirk Corporation  
Heatfab Division  
130 Industrial Blvd.  
Turners Falls, MA 01376  
Phone: 1-800-772-0739  
[www.heat-fab.com](http://www.heat-fab.com)

## **2.14 COMBUSTION AIR**

The AERCO Gas-Fired Heater Venting and Combustion Air Guide, GF-5050 MUST be consulted before any flue or inlet air venting is designed or installed. Air supply is a direct requirement of ANSI 223.1, NFPA-54, CSA B149.1 and local codes. These codes should be consulted before a permanent design is determined.

The combustion air must be free of chlorine, halogenated hydrocarbons or other chemicals that can become hazardous when used in gas-fired equipment. Common sources of these compounds are swimming pools, degreasing compounds, plastic processing, and refrigerants. Whenever the environment contains these types of chemicals, combustion air MUST be supplied from a clean area outdoors for the protection and longevity of the equipment and warranty validation.

The more common methods of combustion air supply are outlined in the following paragraphs. For combustion air supply from ducting, consult the AERCO GF-5050, Gas Fired Venting and Combustion Air Guide.

### **2.14.1 Combustion From Outside the Building**

Air supplied from outside the building must be provided through two permanent openings. For each unit these two openings must have a free area of not less than one square inch for each 4000 BTUs input of the equipment or 250 square inches of free area. The free area must take into account restrictions such as louvers and bird screens. For Canada installations, refer to the requirements specified in CSA B149.1-10, 8.4.1 and 8.4.3.

### **2.14.2 Combustion Air from Inside the Building**

When combustion air is provided from within the building, it must be supplied through two permanent openings in an interior wall. Each opening must have a free area of not less than one square inch per 1000 BTUH of total input or 1000 square inches of free area. The free area must take into account any restrictions, such as louvers.

## **2.15 SEALED COMBUSTION**

The AERCO Innovation Water Heater is UL listed for 100%-sealed combustion. For sealed combustion installations, the screen inlet air ductwork must then be attached directly to the unit's air inlet.

In a sealed combustion air application, the combustion air ducting pressure losses must be taken into account when calculating the total maximum allowable venting run. See the AERCO Innovation Venting and Combustion Air Guide, GF-5050. When using the heater in a sealed combustion air configuration, each unit must have a minimum 6 inch diameter connection at the unit.

This Page Is Intentionally Blank



## CHAPTER 3 OPERATION

### 3.1 INTRODUCTION

The information in this Chapter provides a guide to the operation of the Innovation Water Heater using the Control Panel mounted on the front of the unit. It is imperative that the initial startup of this unit be performed by factory trained personnel. Operation prior to initial startup by factory trained personnel will void the equipment warranty. In addition, the following WARNINGS and CAUTIONS must be observed at all times.

 **CAUTION** 

All of the installation procedures in Chapter 2 must be completed before attempting to start the unit.

 **WARNING** 

ELECTRICAL VOLTAGES IN THIS SYSTEM INCLUDE 120 AND 24 VOLTS AC. IT MUST BE SERVICED ONLY BY FACTORY CERTIFIED SERVICE TECHNICIANS

 **WARNING** 

DO NOT ATTEMPT TO DRY FIRE THE UNIT. STARTING THE UNIT WITHOUT A FULL WATER LEVEL CAN SERIOUSLY DAMAGE THE UNIT AND MAY RESULT IN INJURY TO PERSONNEL OR PROPERTY DAMAGE. THIS SITUATION WILL VOID ANY WARRANTY.

### 3.2 CONTROL PANEL DESCRIPTION

The Innovation Control Panel shown in Figure 3-1 contains all of the controls, indicators and displays necessary to operate, adjust and troubleshoot the Innovation Water Heater. These operating controls, indicators and displays are listed and described in Table 3-1. Additional information on these items is provided in the individual operating procedures provided in this Chapter.

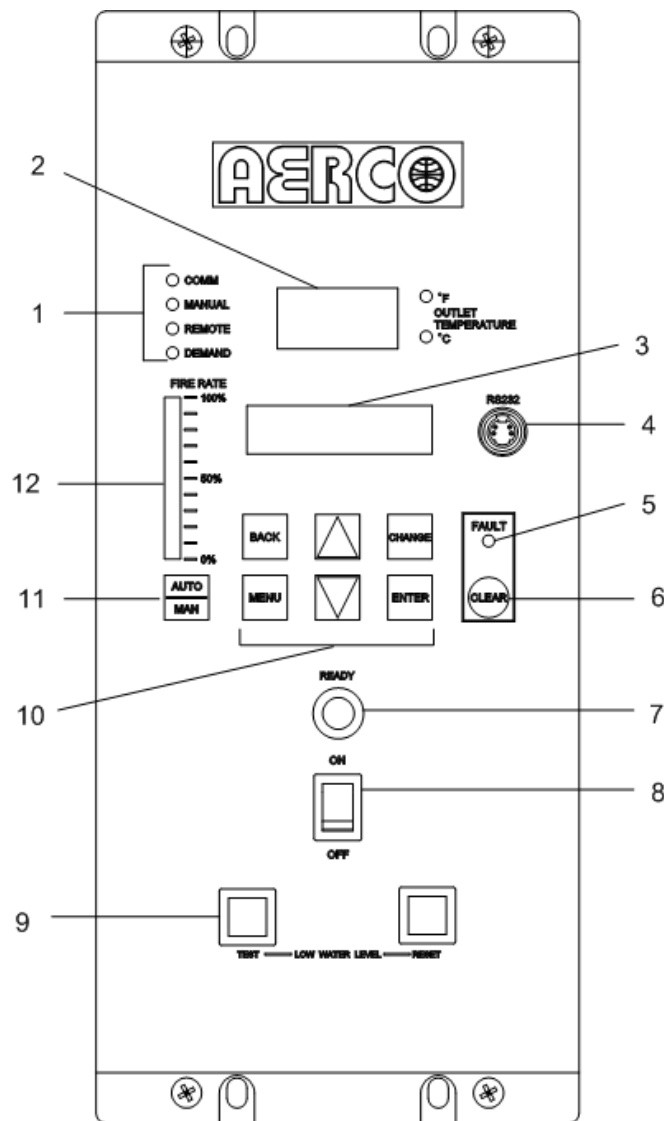

**Figure 3-1. Control Panel Front View**

**Table 3-1 Operating Controls, Indicators and Displays**

ITEM NO.	CONTROL, INDICATOR OR DISPLAY	FUNCTION
1	<b><u>LED Status Indicators</u></b>  <b>COMM</b>  <b>MANUAL</b>  <b>REMOTE</b>  <b>DEMAND</b>	Four Status LEDs indicate the current operating status as follows:  Lights when RS-232 communication is occurring  Lights when the unit is being controlled using the front panel keypad.  Lights when the unit is being controlled by an external signal from an Energy Management System  Lights when there is a demand for heat.
2	<b>OUTLET TEMPERATURE</b> Display	3-Digit, 7-Segment LED display continuously displays the outlet water temperature. The °F or °C LED next to the display lights to indicate whether the displayed temperature is in degrees Fahrenheit or degrees Celsius. The °F or °C blinks when operating in the Deadband Mode.
3	VFD Display	Vacuum Fluorescent Display (VFD) consists of 2 lines each capable of displaying up to 16 alphanumeric characters. The information displayed includes:  Startup Messages Fault Messages Operating Status Messages Menu Selection
4	<b>RS-232</b> Port	Port permits a Laptop Computer or External Modem to be connected to the unit's Control Panel.
5	<b>FAULT</b> Indicator	Red <b>FAULT</b> LED indicator lights when a heater alarm condition occurs. An alarm message will appear in the VFD.
6	<b>CLEAR</b> Key	Turns off the <b>FAULT</b> indicator and clears the alarm message if the alarm is no longer valid. Lockout type alarms will be latched and cannot be cleared by simply pressing this key. Troubleshooting may be required to clear these types of alarms.
7	<b>READY</b> Indicator	Lights <b>ON/OFF</b> switch is set to <b>ON</b> and all Pre-Purge conditions have been satisfied.
8	<b>ON/OFF</b> Switch	Enables and disables heater operation.
9	<b>LOW WATER LEVEL</b> <b>TEST/RESET</b> Switches	Allows operator to test operation of the water level monitor. Pressing <b>TEST</b> opens the water level probe circuit and simulates a Low Water Level alarm. Pressing <b>RESET</b> resets the water level monitor circuit. Pressing the <b>CLEAR</b> key (item 6) resets the display.

**Table 3-1 Operating Controls, Indicators and Displays – Continued**

ITEM NO.	CONTROL, INDICATOR OR DISPLAY	FUNCTION
10	<p><b><u>MENU Keypad</u></b></p> <p><b>MENU</b></p> <p><b>BACK</b></p> <p><b>▲ (UP) Arrow</b></p> <p><b>▼ (DOWN) Arrow</b></p> <p><b>CHANGE</b></p> <p><b>ENTER</b></p>	<p>Consists of 6 keys which provide the following functions for the Control Panel Menus:</p> <p><b>MENU</b> Steps through the main menu categories shown in Figure 3-2. The Menu categories wrap around in the order shown.</p> <p><b>BACK</b> Allows you to go back to the previous menu level without changing any information. Continuously pressing this key will bring you back to the default status display in the VFD. Also, this key allows you to go back to the top of a main menu category.</p> <p><b>▲ (UP) Arrow</b> When in one of the main menu categories (Figure 3-2), pressing the ▲ arrow key will select the displayed menu category. If the <b>CHANGE</b> key was pressed and the menu item is flashing, pressing the ▲ arrow key will increment the selected setting.</p> <p><b>▼ (DOWN) Arrow</b> When in one of the main menu categories (Figure 3-2), pressing this key will select the displayed menu category. If the <b>CHANGE</b> key was pressed and the menu item is flashing, pressing the ▼ arrow key will decrement the selected setting.</p> <p><b>CHANGE</b> Permits a setting to be changed (edited). When the <b>CHANGE</b> key is pressed, the displayed menu item will begin to flash. Pressing the ▲ or ▼ arrow key when the item is flashing will increment or decrement the displayed setting.</p> <p><b>ENTER</b> Saves the modified menu settings in memory. The display will stop flashing.</p>
11	<p><b>AUTO/MAN Switch</b></p>	<p>This switch toggles the heater between the Automatic and Manual modes of operation. When in the Manual (<b>MAN</b>) mode, the front panel controls are enabled and the <b>MANUAL</b> status LED lights.</p> <p>When in the Automatic (<b>AUTO</b>) mode, the <b>MANUAL</b> status LED will be off and the front panel controls disabled.</p>
12	<p><b>VALVE POSITION Bargraph</b></p>	<p>20 segment red LED bargraph continuously shows the Air/Fuel Valve position in 5% increments from 0 to 100%</p>

### 3.3 CONTROL PANEL MENUS

The Control Panel incorporates an extensive menu structure which permits the operator to set up, and configure the unit. The menu structure consists of five major menu categories which are applicable to this manual. These categories are shown in Figure 3-2. Each of the menus shown, contain options which permit operating parameters to be viewed or changed. The menus are protected by a password levels to prevent unauthorized use.

Prior to entering the correct password, the options contained in the Operation, Setup, Configuration and Tuning Menu categories can be viewed. However, with the exception of Internal Setpoint Temperature (Configuration Menu), none of the viewable menu options can be changed.

Once the valid level 1 password (159) is entered, the options listed in the Setup, Configuration, Water Heater Management (WHM) and Tuning Menus can be viewed and changed, if desired.

#### 3.3.1 Menu Processing Procedure

Accessing and initiating each menu and option is accomplished using the Menu Keys shown in Figure 3-1. Therefore, it is imperative that you be thoroughly familiar with the following basic steps before attempting to perform specific menu procedures.

##### **Menu Processing Procedure**

1. The Control Panel will normally be in the Operating Menu and the VFD will display the current unit status. Pressing the ▲ or ▼ arrow key will display the other available data items in the Operating Menu.
2. Press the MENU key. The display will show the Setup Menu, which is the next menu category shown in Figure 3-2. This menu contains the Password option which must be entered if other menu options will be changed.
3. Continue pressing the MENU key until the desired menu is displayed.
4. With the desired menu displayed, press the ▲ or ▼ arrow key. The first option in the selected menu will be displayed.
5. Continue to press the ▲ or ▼ arrow key until the desired menu option is displayed. Pressing the ▲ arrow key will display the available menu options in the Top-Down sequence. Pressing the ▼ arrow key will display the options in the Bottom-Up sequence. The menu options will wrap-around after the first or last available option is reached.
6. To change the value or setting of a displayed menu option, press the CHANGE key. The displayed option will begin to flash. Press the ▲ or ▼ arrow key to scroll through the available menu option choices for the option to be changed. The menu option choices do not wrap around.
7. To select and store a changed menu item, press the ENTER key.

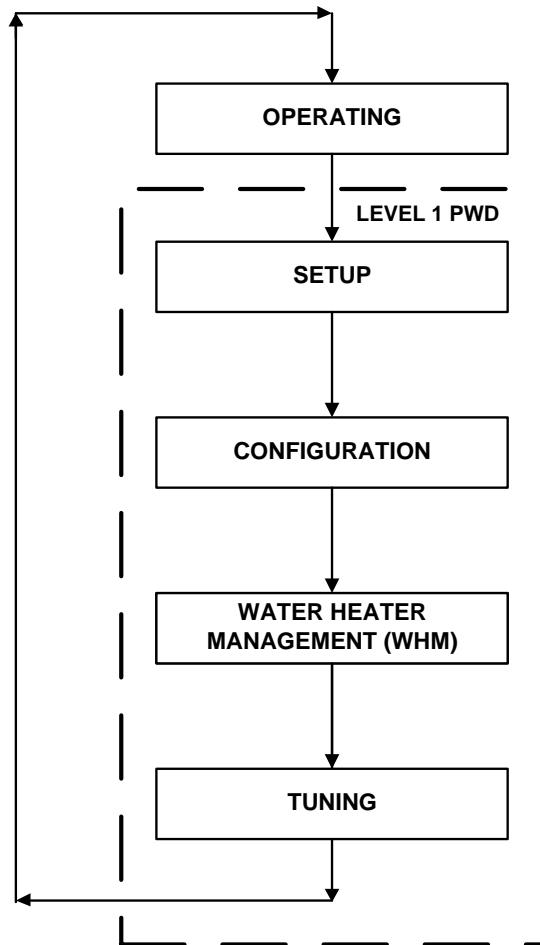

**NOTE:**  
WHM MENU IS ONLY DISPLAYED  
WHEN THE UNIT TYPE OPTION  
IN THE CONFIGURATION MENU  
IS SET TO INNOVATION WH.

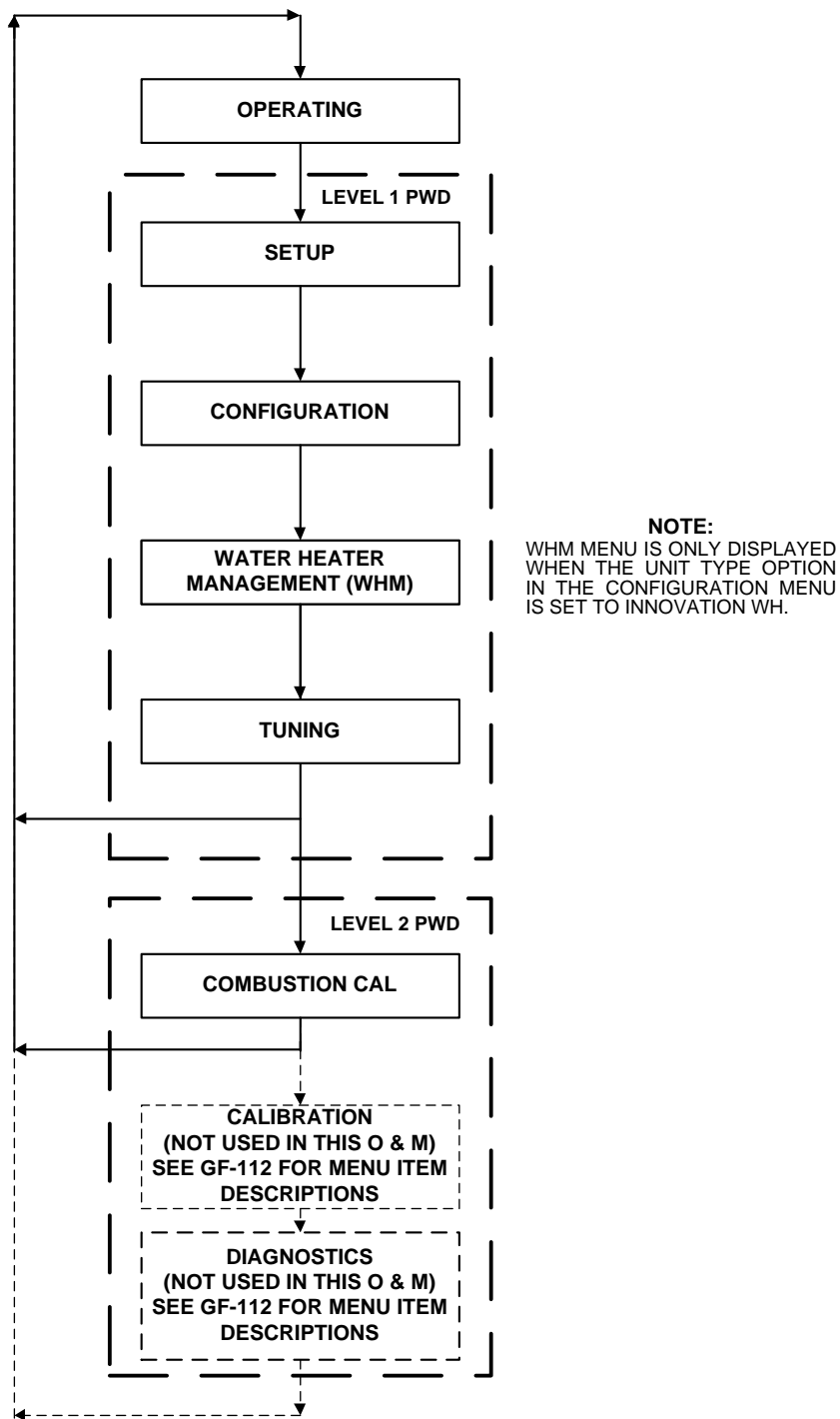

Figure 3-2. Menu Structure

**NOTE**

The following paragraphs provide brief descriptions of the options contained in each menu. Refer to Appendix A for detailed descriptions of each menu option. Refer to Appendix B for listings and descriptions of displayed startup, status and error messages.

**3.4 OPERATING MENU**

The Operating Menu displays a number of key operating parameters for the unit as listed in Table 3-2. This menu is “Read-Only” and does not allow personnel to change or adjust any displayed items. Since this menu is “Read-Only”, it can be viewed at any time without entering a password. Pressing the ▲ arrow key to display the menu items in the order listed (Top-Down). Pressing the ▼ arrow key will display the menu items in reverse order (Bottom-Up).

**Table 3-2. Operating Menu**

Menu Item Display	Available Choices or Limits		Default
	Minimum	Maximum	
Status Message			
Active Setpoint	40°F	240°F	
Inlet Temp	40°F	140°F	
Air Temp	-70°F	245°F	
Outdoor Temp*	-70°F	130°F	
Valve Position In	0%	100%	
Valve Position Out	0%	100%	
FFWD Temp	80°F	160°F	
Flame Strength	0%	100%	
Run Cycles	0	999,999,999	
Run Hours	0	999,999,999	
Fault Log	0	19	0

**NOTE**

The Outdoor Temp display item shown with an asterisk in Table 3-2 will not be displayed unless the Outdoor Sensor function has been enabled in the Configuration Menu (Table 3-4).

**3.5 SETUP MENU**

The Setup Menu (Table 3-3) permits the operator to enter the unit password (159) which is required to change the menu options. To prevent unauthorized use, the password will time-out after 1 hour. Therefore, the correct password must be reentered when required. In addition to permitting password entries, the Setup Menu is also used to enter date and time, units of temperature measurements and entries required for external communication and control of the unit via the RS-232 port. A view-only software version display is also provided to indicate the current Control Box software version.



**Table 3-3. Setup Menu**

Menu Item Display	Available Choices or Limits		Default
	Minimum	Maximum	
Passsword	0	9999	0
Language	English		English
Time	12:00 am	11:59 pm	
Date	01/01/00	12/31/99	
Unit of Temp	Fahrenheit or Celsius		Fahrenheit
Comm Address	0	127	0
Baud Rate	2400, 4800, 9600, 19.2K		9600
Software	Ver 0.00	Ver 9.99	

### 3.6 CONFIGURATION MENU

The Configuration Menu shown in Table 3-4 permits adjustment of the Internal Setpoint (Setpt) temperature regardless of whether the valid password has been entered. Setpt is required for operation in the Constant Setpoint mode. The remaining options in this menu require the valid password to be entered, prior to changing existing entries. This menu contains a number of other configuration settings which may or may not be displayed, depending on the current operating mode setting.

#### NOTE

The Configuration Menu settings shown in Table 3-4 are Factory-Set in accordance with the requirements specified for each individual order. Therefore, under normal operating conditions, no changes will be required.

**Table 3-4. Configuration Menu**

Menu Item Display	Available Choices or Limits		Default
	Minimum	Maximum	
Internal Setpt	Lo Temp Limit	Hi Temp Limit	130°F
Unit Type	KC Boiler, KC Boiler LN, BMK Boiler, BMK Boiler LN, BMK Boiler Dual, KC Water Heater, KC Water Heater LN, Innovation WH		Innovation WH
Unit Size (Only if Unit Type is Innovation WH)	600 MBH, 800 MBH, 1060 MBH, 1350 MBH		600, 800 or 1060 or 1350 MBH
Fuel Type	Natural Gas, Propane		Natural Gas
Water Heater Mode	Constant Setpoint, Remote Setpoint,		Constant Setpoint

**Table 3-4. Configuration Menu - Continued**

Menu Item Display	Available Choices or Limits		Default
	Minimum	Maximum	
Remote Signal (If Mode = Remote Setpoint, Direct Drive or Combination)	4 – 20 mA/1 – 5V 0 -20 mA/0 – 5V PWM Input (BMS) Network		4 – 20 mA, 1-5V
Bldg Ref Temp (If Mode = Outdoor Reset)	40°F	230°F	70°F
Reset Ratio (If Mode = Outdoor Reset)	0.1	9.9	1.2
Outdoor Sensor	Enabled or Disabled		Disabled
System Start Tmp (If Outdoor Sensor = Enabled)	30°F	100°F	60°F
Setpt Lo Limit	40°F	Setpt Hi Limit	60°F
Setpt Hi Limit	Setpt Lo Limit	220°F	140°F
Temp Hi Limit	40°F	240°F	160°F
Max Valve Position	40%	100%	100%
Pump Delay Timer	0 min.	30 min.	0 min.
Aux Start On Dly	0 sec.	120 sec.	0 sec.
Failsafe Mode	Shutdown or Constant Setpt		Shutdown
*Analog Output (See <b>CAUTION</b> at end of Table 3-4 )	Off, Setpoint, Outlet Temp, Valve Position 4-20 mA, Valve Position 0-10V		*Valve Position 0-10V
Low Fire Timer	2 sec.	600 sec.	2 sec.
Setpt Limiting	Enabled or Disabled		Disabled
Setpt Limit Band	0°F	10°F	0
Network Timeout	5 Sec	999 Sec	30 Sec
HI DB Setpt EN	0%	100%	30%
Demand Offsert	0	25	0
Deadband High	0	25	0
Deadband Low	0	25	0

**\* ⚠ CAUTION ⚠**

DO NOT CHANGE the Analog Output Menu Item from its Default setting (Valve Position 0-10V).

### 3.7 WATER HEATER MANAGEMENT (WHM) MENU

The WHM Menu in each C-More can only be viewed when the *Unit Type* option in the Configuration Menu is set to *Innovation WH*. Most of the options in this menu are preset at the factory and cannot be altered by the user. Therefore, the WHM Menu contains only eight (8) user-selectable menu options. These menu options are listed in Table 3-5. Descriptions for each of these menu items are included in Appendix A.

**Table 3-5. WHM Menu**

Menu Item Display	Available Choices or Limits		Default
	Minimum	Maximum	
WHM Mode	Off, WHM Slave, WHM Master		Off
WHM Setpoint	40°F	200°F	130°F
WHM Nxt On FR	16%	100%	75%
WHM Nxt Off FR	16%	100%	35%
Lead/Lag Hours	25	225	72
Setback Setpoint	40°F	220°F	130°F
Setback Start	12:00am	11:59pm	12:00am
Setback End	12:00am	11:59pm	12:00am
*WHM Auto Mstr	Yes or No		No
*WHM Auto Timer	10 sec.	120 sec.	30 sec.

**\*NOTE**

The Level 2 Password (6817) in the Setup Menu must be entered to view or change the WHM Auto Mstr and WHM Auto Timer options.

### 3.8 TUNING MENU

The Tuning Menu items in Table 3-6 are Factory set for each individual unit. Do not change these menu entries unless specifically requested to do so by Factory-Trained personnel.

**Table 3-6. Tuning Menu**

Menu Item Display	Available Choices or Limits		Default
	Minimum	Maximum	
Prop Band	1°F	120°F	8°F
Integral Gain	0.00	2.00	1.6
Derivative Time	0.0 min	2.00 min	0.10 min
Reset Defaults?	Yes, No, Are You Sure?		No

### 3.9 START SEQUENCE

When the Control Box **ON/OFF** switch is set to the ON position, it checks all pre-purge safety switches to ensure they are closed. These switches include:

- Safety Shut-Off Valve Proof of Closure (POC) switch
- Low Water Level switch
- High Water Temperature switch
- High Gas Pressure switch
- Low Gas Pressure switch
- Blower Proof switch

If all of the above switches are closed, the **READY** light above the **ON/OFF** switch will light and the unit will be in the Standby mode.

When there is a demand for hot water, the following events will occur:

#### NOTE

If any of the Pre-Purge safety device switches are open, the appropriate fault message will be displayed. Also, the appropriate messages will be displayed throughout the start sequence, if the required conditions are not observed.

The DEMAND LED status indicator will light.

The unit checks to ensure that the Proof of Closure (POC) switch in the downstream Safety Shut-Off Valve (SSOV) is closed. See Figure 3-3 for SSOV location.

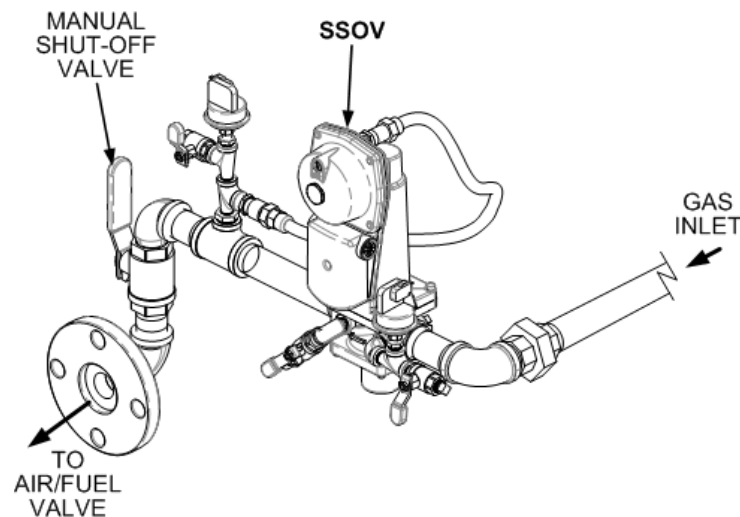

**Figure 3-3. SSOV Location (INN1060 Gas Train)**

With all required safety device switches closed, a purge cycle will be initiated and the following events will occur:

- (a) The Blower relay energizes and turns on blower.
- (b) The Air/Fuel Valve rotates to the full-open purge position and closes purge position switch. The dial on the Air/Fuel Valve (Figure 3-4) will read 100 to indicate that it is full-open (100%).
- (c) The VALVE POSITION bargraph will show 100%.

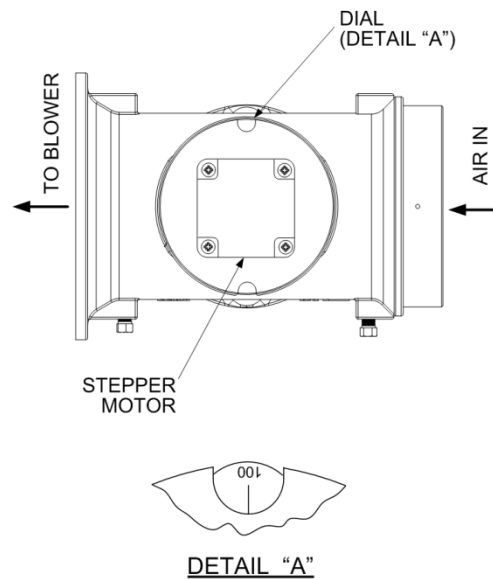

**Figure 3-4. Air/Fuel Valve In Purge Position**

Next, the blower proof switch on the Air/Fuel Valve (Figure 3-5) closes. The display will show *Purging* and indicate the elapsed time of the purge cycle in seconds.

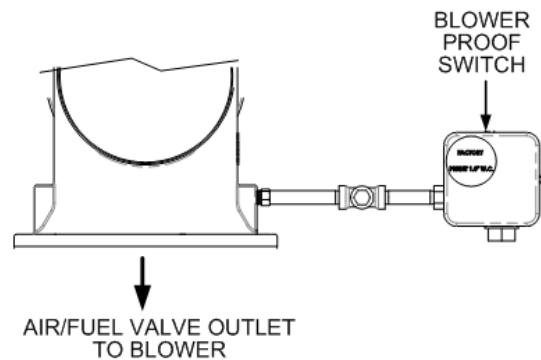

**Figure 3-5. Blower Proof Switch**

Upon completion of the purge cycle, the Control Box initiates an ignition cycle and the following events occur:

- (a) The Air/Fuel Valve rotates to the low-fire ignition position and closes the ignition switch. The dial on the Air/Fuel Valve (Figure 3-6) will read between 25 and 35 to indicate that the valve is in the low-fire position.
- (b) The igniter relay is activated and provides ignition spark.
- (c) The gas Safety Shut-Off Valve (SSOV) is energized (opened) allowing gas to flow into the Air/Fuel Valve.

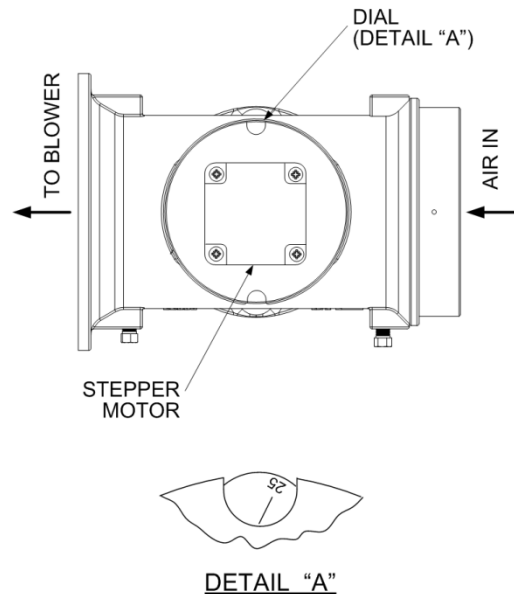

**Figure 3-6. Air/Fuel Valve In Ignition Position**

Up to 7 seconds will be allowed for ignition to be detected. The igniter relay will be turned off one second after flame is detected.

After 2 seconds of continuous flame, *Flame Proven* will be displayed and the flame strength will be indicated. After 5 seconds, the current date and time will be displayed in place of the flame strength.

With the unit firing properly, it will be controlled by the temperature controller circuitry. The heater's VALVE POSITION will be continuously displayed on the front panel bar-graph.

Once the demand for hot water has been satisfied, the Control Box will turn off the SSOV gas valve. The blower relay will be deactivated and the Air/Fuel Valve will be closed. *Standby* will be displayed.

### 3.10 START/STOP LEVELS

The start and stop levels are the Air/Fuel Valve positions (% open) that start and stop the unit, based on load. These levels are Factory preset as follows:

Start Level: 25%

Stop Level: 16%

Normally, these settings should not require adjustment.

Note that the energy input is not linearly related to the Air/Fuel Valve position. Refer to Table 3-7 for the relationship between the energy input and Air/Fuel Valve position for a unit running on natural gas.

**Table 3-7. Relationship Between Air/Fuel Valve Position and Energy Input For Unit Running On Natural Gas**

Air/Fuel Valve Position (% Open)	Innovation Water Heater Model: Energy Input (BTU/Hr.)			
	INN600	INN800	INN1060	INN1350
16%	45,000	45,000	45,000	45,000
20%	87,000	97,000	97,000	181,000
30%	174,000	192,000	222,000	370,000
40%	243,000	330,000	416,000	665,000
50%	36,000	424,000	520,000	870,000
60%	370,000	486,000	715,000	1,001,000
80%	483,000	615,000	845,000	1,203,000
100%	600,000	800,000	1,060,000	1,350,000

This Page Is Intentionally Blank



## CHAPTER 4 INITIAL START-UP

### 4.1 INITIAL START-UP REQUIREMENTS

The requirements for the initial start-up of the Innovation Water Heater consists of the following:

- Complete installation (Chapter 2)
- Set proper controls and limits (Chapter 3)
- Perform combustion calibration
- Test safety devices (Chapter 5)

All applicable installation procedures in Chapter 2 must be fully completed prior to performing the initial start-up of the unit. The initial start-up must be successfully completed prior to putting the unit into service. Starting a unit without the proper piping, venting, or electrical systems can be dangerous and may void the product warranty. The following start-up instructions should be followed precisely in order to operate the unit safely and at a high thermal efficiency, with low flue gas emissions.

Initial unit start-up must be performed ONLY by AERCO factory trained start-up and service personnel. After performing the start-up procedures in this Chapter, it will be necessary to perform the Safety Device Testing procedures specified in Chapter 5 to complete all initial unit start-up requirements.

An AERCO Gas Fired Startup Sheet, included with each Innovation Heater, must be completed for each unit for warranty validation and a copy must be returned promptly to AERCO at:

**AERCO International, Inc.**  
**100 Oritani Drive**  
**Blauvelt, New York 10913**



DO NOT ATTEMPT TO DRY FIRE THE HEATER. STARTING THE UNIT WITHOUT A FULL WATER LEVEL CAN SERIOUSLY DAMAGE THE UNIT AND MAY RESULT IN INJURY TO PERSONNEL OR PROPERTY DAMAGE. THIS SITUATION WILL VOID ANY WARRANTY.

### 4.2 TOOLS AND INSTRUMENTATION FOR COMBUSTION CALIBRATION

To properly perform combustion calibration, the proper instruments and tools must be used and correctly attached to the unit. The following paragraphs outline the necessary tools and instrumentation as well as their installation.

#### 4.2.1 Required Tools & Instrumentation

The following tools and instrumentation are necessary to perform combustion calibration of the unit:

- Digital Combustion Analyzer: Oxygen accuracy to  $\pm 0.4\%$ ; Carbon Monoxide (CO) and Nitrogen Oxide (NO<sub>x</sub>) resolution to 1PPM.
- 16 inch W.C. manometer or equivalent gauge and plastic tubing.
- Multimeter (Capable of measuring 0 – 10  $\mu$ A)
- 1/8 inch NPT-to-barbed fittings for use with gas supply manometer or gauge.
- Small and large flat blade screwdrivers.
- Tube of silicone adhesive

#### 4.2.2 Installing Gas Supply Manometer

The gas supply manometer is installed in the gas train as follows:

##### Installing Gas Supply Manometer

1. Close the main manual gas supply shut-off valve upstream of the unit.
2. Remove the front door and left side panels from the heater to access the gas train components.
3. Remove the 1/4 inch NPT pipe plug from the leak detection ball valve on the downstream side of the Safety Shut Off Valve (SSOV) as shown in Figure 4-1.
4. Install a NPT-to-barbed fitting into the tapped plug port.
5. Attach one end of the plastic tubing to the barbed fitting and the other end to the 16 inch W.C. manometer.

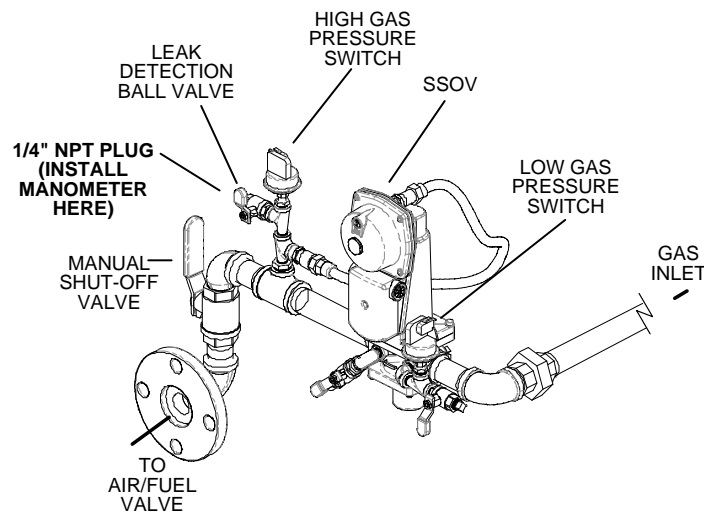

**Figure 4-1. 1/4 Inch Gas Plug Location (INN1060 Gas Train)**

#### 4.2.3 Accessing the Analyzer Probe Port

The unit contains a 1/8" NPT port at the rear of the exhaust manifold. This port is located above the condensate drain connection as shown in Figure 4-2. Prepare the port for the combustion analyzer probe as follows:

##### Accessing Analyzer Probe Port

1. Refer to Figure 4-2 and remove the 1/8" NPT plug from the rear of the exhaust manifold.
2. If necessary, adjust the stop on the combustion analyzer probe so it will extend mid-way into the flue gas flow. DO NOT install the probe at this time

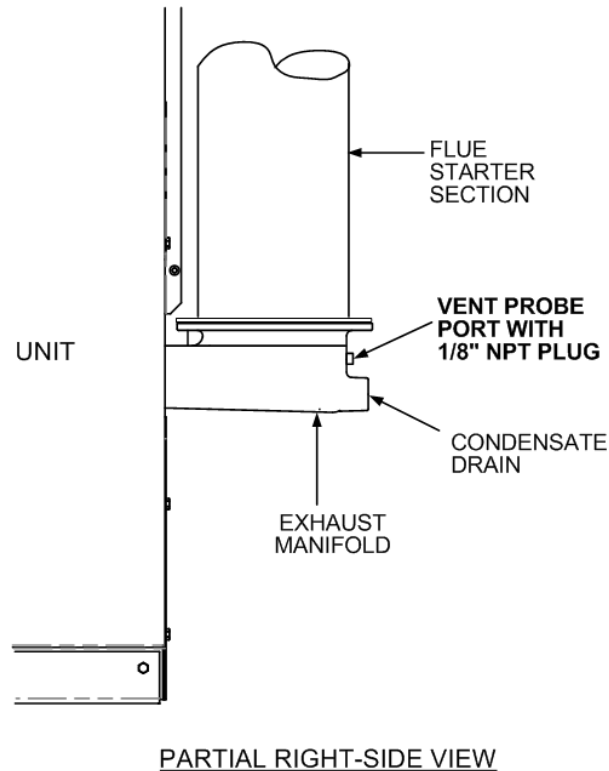

**Figure 4-2 Analyzer Probe Hole Location**

**IMPORTANT**

For Innovation Water Heater installations in Korea, refer to the Natural Gas Combustion Calibration procedures in Appendix .

**4.2.4 Connecting Multimeter to Flame Detector**

During Combustion Calibration, the flame strength generated by the flame detector is measured using a multimeter set to the  $\mu\text{A}$  scale. The flame detector is mounted on the flange of the blower side intake manifold as shown in Figure 4-3.

Proceed as follows to set up the multimeter to measure the flame strength current:

**Connecting Multimeter to Measure Flame Strength**

1. Refer to Figure 4-3 and remove the right side panel from the unit to access the flame detector.
2. Disconnect the flame detector wire lead 135 from the detector and connect the multimeter in series with the wire lead using alligator clips as shown in Figure 4-3.
3. Ensure that the multimeter is set to the  $\mu\text{A}$  scale.

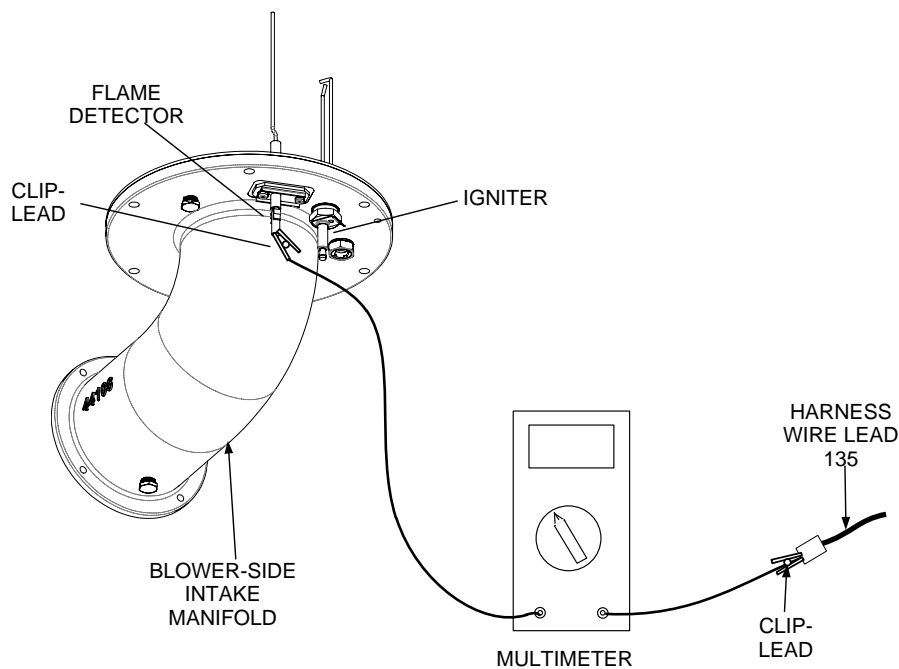

**Figure 4-3 Flame Strength Set-Up Using Multimeter**

### 4.3 NATURAL GAS COMBUSTION CALIBRATION

The Innovation Heater is combustion calibrated at the factory prior to shipping. However, recalibration as part of initial start-up is necessary due to changes in the local altitude, gas BTU content, gas supply piping and supply regulators. Start-Up & Registration Test Data sheets are shipped with each unit. These sheets must be filled out and returned to AERCO for proper Warranty Validation.

It is important to perform the calibration procedure as outlined in the following steps. This will keep readjustments to a minimum and provide optimum performance.

**Natural Gas Combustion Calibration**

1. Open the water supply and return valves to the unit and ensure that the system pumps are running.
2. Open the natural gas supply valve(s) to the unit.
3. Set the control panel **ON/OFF** switch to the **OFF** position.
4. Turn on external AC power to the unit. The display will show **LOSS OF POWER** and the time and date.
5. Set the unit to the Manual Mode by pressing the **AUTO/MAN** key. A flashing Manual Valve Position message will be displayed with the present position in %. Also, the **MANUAL** LED will light.
6. Adjust the air/fuel valve position to 0% by pressing the ▼ arrow key.
7. Ensure that the leak detection ball valve downstream of the SSOV is open.
8. Set the ON/OFF switch to the ON position.
9. Change the valve position to 29% using the ▲ arrow key. The unit should begin its start sequence and fire.
10. Next, verify that the gas pressure downstream of the SSOV is within the appropriate range shown below for the Innovation Model being tested. If gas pressure adjustment is required, remove the brass hex nut on the SSOV actuator to access the gas pressure adjustment screw (Figure 4-4). Make gas pressure adjustments using a flat-tip screwdriver to obtain a gas pressure reading within the required range for the INN model being tested.

<b>INNOVATION MODEL</b>	<b>GAS PRESSURE RANGE DOWNSTREAM OF SSOV</b>
INN 1350	3.0" – 3.2" W.C.
INN1060	2.6" – 2.8" W.C.
INN800	1.5" – 1.7" W.C.
INN600	0.9" – 1.1" W.C.

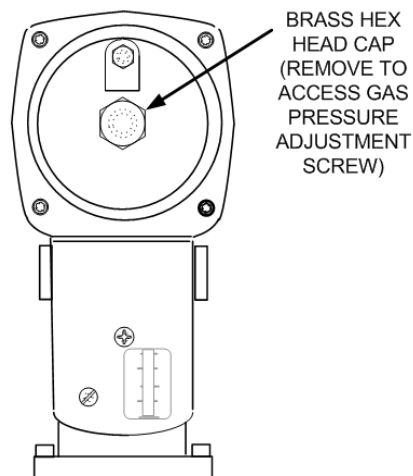

TYPICAL SSOV ACTUATOR WITH REGULATOR

**Figure 4-4. Gas Pressure Adjustment Screw Location**

**Natural Gas Combustion Calibration - Continued**

11. Next, decrease the valve open position to 16% using the ▼ arrow key. Verify that the gas pressure at the inlet of the SSOV is 11.0" W.C. Readjust the inlet gas pressure if necessary.
12. Insert the combustion analyzer probe into the 1/8" port at the rear of the exhaust manifold. Allow enough time for the combustion analyzer to settle.
13. Verify that the oxygen (O<sub>2</sub>) level is within the range shown below. Also, ensure that the carbon monoxide (CO), nitrogen oxide (NO<sub>x</sub>) and flame strength readings are within the values shown.

**Combustion Oxygen Level at 16% Valve Position**

Oxygen % ± 0.5	Carbon Monoxide	NO <sub>x</sub>	Flame Strength
6.5 %	<50 ppm	<15 ppm	>2.0 μA

14. If the oxygen level is not within the required tolerance, the gas pressure on the downstream side of the SSOV must be adjusted using the adjustment screw on the SSOV regulator (Figure 4-3). Slowly rotate the gas pressure adjustment (approximately 1/4-turn increments). Allow the combustion analyzer to stabilize following each adjustment. Clockwise rotation reduces the oxygen level, while counterclockwise rotation increases the oxygen level.
15. Once the oxygen level is within the required range listed in step 13, the gas pressure on the downstream side of the SSOV should be within the appropriate range shown below for the Innovation Model being tested.

INNOVATION MODEL	GAS PRESSURE RANGE DOWNSTREAM OF SSOV
INN 1350	3.0" – 3.2" W.C.
INN1060	2.6" – 2.8" W.C.
INN800	1.5" – 1.7" W.C.
INN600	0.9" – 1.1" W.C.

16. Replace the brass cap on the SSOV gas pressure adjustment if it was previously removed.
17. Following combustion calibration at the 16% valve position, check the combustion readings at each of the valve positions listed below and record the readings on the Start-Up & Registration data sheets provided with the unit. During these checks, **DO NOT** attempt to adjust the downstream gas pressure using the SSOV gas pressure adjustment screw.

**NOTE**

Based on the water heater load, it may not be possible to obtain data at all of the points listed without encountering an Over-Temp condition.

18. Valve Positions to be checked:

- 20%,
- 30%,
- 40%,
- 50%,
- 60%,
- 80%,
- 100%

19. This completes the combustion calibration procedures.

#### 4.4 REASSEMBLY

Once the combustion calibration adjustments are properly set, the unit can be reassembled for service operation.

##### **Reassembly**

1. Set the ON/OFF switch in the OFF position.
2. Disconnect AC power from the unit.
3. Shut off the gas supply to the unit.
4. Remove the manometer and barbed fittings and reinstall the NPT plug using a suitable pipe thread compound.
5. Remove the combustion analyzer probe from the 1/8" vent hole in the exhaust manifold. Replace the 1/8" NPT plug in the manifold.
6. Replace the unit's side panels and front door.

#### 4.5 TEMPERATURE CONTROL CALIBRATION

The unit normally comes factory set and calibrated for a 130°F setpoint (default value). However, if a different setpoint temperature is desired, it can be changed using the procedure in paragraph 4.5.1. If the setpoint is changed, it must be done prior to temperature control calibration.

There are two primary adjustments for performing temperature calibration. These are *Min Load Adj* and *Max Load Adj* (minimum and maximum load adjustment).

Adjustments to these settings are made at minimum and maximum load conditions and should be made in small increments from 1 to 3 degrees. After making an adjustment, the outlet water temperature must be allowed to settle for several minutes prior to making any further adjustments.

When calibrating temperature control, observe the following:

##### **Temperature Control Calibration**

1. The unit must be in the Auto mode of operation.
2. The Outlet Feedback option in the Tuning Menu must be set to DISABLED while performing calibration. Upon completion of calibration, the Outlet Feedback must be set back to ENABLE.
3. Monitor the OUTLET TEMPERATURE display and VALVE POSITION bar-graph to set load conditions and observe the effect of adjustments.
4. Perform the calibration using the Tuning Menu of the C-More Control Box.
5. Make small adjustments and allow time between adjustments for the outlet water temperature to stabilize.
6. Maintain water flow as constant as possible during these adjustments.
7. Ensure that recirculation loops are operational while the calibration is being performed.

Temperature control calibration is accomplished by performing the Minimum and Maximum Load Adjustment procedures in paragraphs 4.5.2 and 4.5.3, respectively.

#### 4.5.1 Setting the Outlet Water Temperature Setpoint

The setpoint temperature of the unit may be changed using the following steps. However, once a setpoint has been changed, recalibration may be necessary. The temperature calibration procedures are provided in paragraphs 4.5.2 and 4.5.3.

To adjust the unit's setpoint, proceed as follows:

##### Setting Outlet Water Temperature Setpoint

1. Press the MENU key until Configuration Menu is displayed.
2. Press the ▲ or ▼ arrow key until Internal Setpt is displayed along with the present setpoint temperature.
3. To change the setpoint, press the CHANGE key. The display will begin to flash.
4. Press the ▲ or ▼ arrow key until the desired setpoint is displayed.
5. Press the ENTER key to save the change.

#### 4.5.2 Minimum Load Adjustment

With the unit in operation, check the temperature control at minimum load as follows:

##### Minimum Load Adjustment

1. While monitoring the VALVE POSITION bar-graph, create a minimum load on the system that will yield a steady valve position between 25% and 35%.

##### NOTE

It may be desirable to shut off the outlet valve and use the hose bib (see Figure 2-4) to simulate a minimum flow load condition.

2. Wait several minutes to allow the outlet temperature to stabilize under load conditions.
3. Once stabilized, the **OUTLET TEMPERATURE** display should read no more than 2 to 3 degrees above the unit's setpoint.
4. If the outlet temperature is stabilized, proceed to the Maximum Load Adjustment procedure in paragraph 4.5.3. If the temperature is not stabilized, proceed to step 5.
5. Press the **MENU** key and select the *Tuning Menu*.
6. Press the ▲ or ▼ arrow key until *Min Load Adj* is displayed.
7. Press the **CHANGE** key. The display will begin to flash.
8. Raise or lower the minimum load adjustment in increments of one or two using the ▲ or ▼ arrow key. Increasing this value will increase outlet water temperature, while decreasing it will decrease outlet water temperature.
9. Press **ENTER** to save the change. Allow time for the system to stabilize between adjustments
10. Repeat steps 5 through 9 as needed until the temperature is stabilized at no more than 2 to 3 degrees above the unit's setpoint.



### 4.5.3 Maximum Load Adjustment

Check the temperature control at maximum load as follows:

#### Maximum Load Adjustment

1. While monitoring the VALVE POSITION bar-graph, create a maximum load on the system that will yield a steady valve position between 80% and 90%.

#### NOTE

It may be necessary to open the outlet valve if it was closed during minimum load adjustment to obtain a sufficient flow rate for maximum adjustment.

2. Wait several minutes to allow the outlet water temperature to stabilize under load conditions.
3. Once stabilized, the OUTLET TEMPERATURE display should read no more than 2 to 3 degrees below the unit's setpoint.
4. If the outlet temperature is stabilized, no adjustment is necessary. If the temperature is not stabilized, proceed to step 5.
5. Press the MENU key and select the Tuning Menu.
6. Press the ▲ or ▼ arrow key until Max Load Adj is displayed.
7. Press the CHANGE key. The display will begin to flash.
8. Raise or lower the maximum load adjustment using the ▲ or ▼ arrow key. Increasing this value will increase outlet water temperature, while decreasing it will decrease water temperature.
9. Press ENTER to save the change. Allow time for the system to stabilize between adjustments.
10. Repeat steps 5 through 9 as needed until the temperature is stabilized 2 to 3 degrees below the unit's setpoint.

If the outlet temperature does not maintain setpoint after a reasonable amount of time and adjustment, contact your local AERCO representative.

#### NOTE:

After performing Temperature Calibration and prior to placing the water heater into service, be sure to set the *Outlet Feedback* option in the *Tuning Menu* back to ON.

#### 4.6 OVER-TEMPERATURE LIMIT SWITCHES

The unit contains both automatic and manual reset over-temperature limit switches. These switches are mounted on a plate as shown in Figure 4-5. The switches can be accessed by opening the front panel door of the unit. The manual reset switch is not adjustable and is permanently fixed at 210°F. This switch will shut down and lock out the heater if the water temperature exceeds 210°F. Following an over-temperature condition, it must be manually reset by pressing the RESET button before the heater can be restarted. The automatic reset over-temperature switch is adjustable and allows the unit to restart, once the temperature drops below its temperature setting. Set the automatic over-temperature switch to the desired setting.

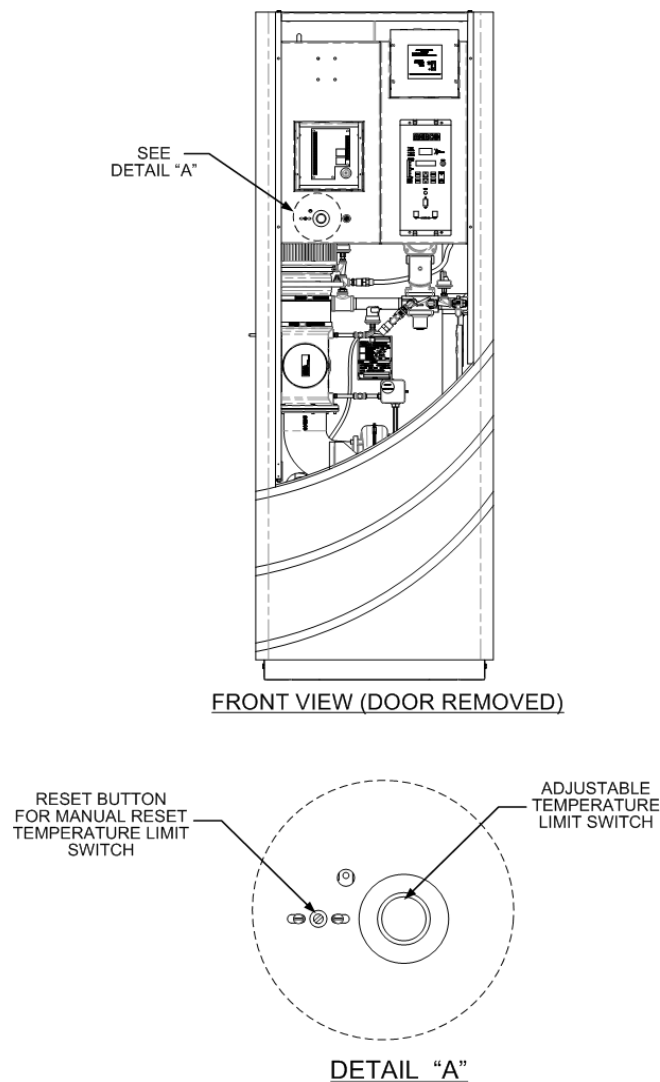

**Figure 4-5. Over Temperature Limit Switch Location**

## CHAPTER 5 SAFETY DEVICE TESTING

### 5.1 TESTING OF SAFETY DEVICES

Periodic safety device testing is required to ensure that the control system and safety devices are operating properly. The heater control system comprehensively monitors all combustion-related safety devices before, during and after the start sequence. The following tests check to ensure that the system is operating as designed.

Operating controls and safety devices should be tested on a regular basis or following service or replacement. All testing must conform to local codes such as ASME CSD-1.

**NOTE:**

MANUAL and AUTO modes of operation are required to perform the following tests. For a complete explanation of these modes, see Chapter 3.

**NOTE:**

It will be necessary to remove the front door and side panels from the unit to perform the following tests.



ELECTRICAL VOLTAGES IN THIS SYSTEM MAY INCLUDE 120 AND 24 VOLTS AC. POWER MUST BE REMOVED PRIOR TO PERFORMING WIRE REMOVAL OR OTHER TEST PROCEDURES THAT CAN RESULT IN ELECTRICAL SHOCK.

### 5.2 LOW GAS PRESSURE FAULT TEST

Refer to Figure 5-1 and ensure that the leak detection ball valve located at the high gas pressure switch is closed.

#### Low Gas Pressure Fault Test

1. Remove the 1/8" plug from the ball valve at the low gas pressure switch shown in the lower portion of Figure 5-1.
2. Install a 0 – 16" W.C. manometer or a W.C. gauge where the 1/8" plug was removed.
3. Slowly open the ball valve near the low gas pressure switch.
4. Place the unit in Manual Mode and adjust the air/fuel valve position (% open) between 25 and 30%.
5. While the unit is firing, slowly close the external manual gas shut-off valve.
6. The unit should shut down and display a *LOW GAS PRESSURE* fault message at approximately 2.6" W.C. The **FAULT** indicator should also start flashing.
7. Fully open the external manual gas shut-off valve and press the **CLEAR** button on the Control Box.
8. The fault message should clear and the **FAULT** indicator should go off. The unit should restart.
9. Upon test completion, close the ball valve and remove the manometer. Replace the 1/8" plug removed in step 1.

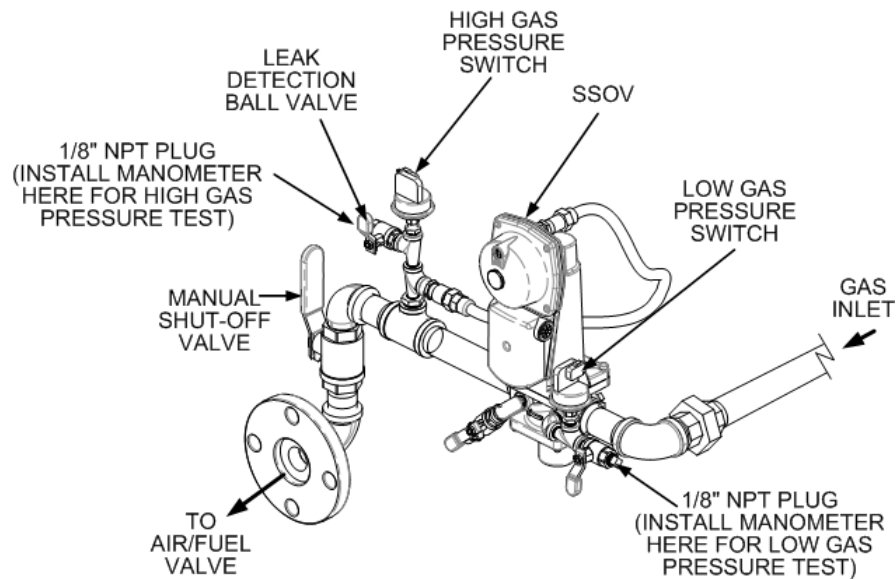

**Figure 5-1. Low & High Gas Pressure Testing (INN1060 Gas Train)**

### 5.3 HIGH GAS PRESSURE FAULT TEST

To simulate a high gas pressure fault, refer to Figure 5-1 and proceed as follows:

#### High Gas Pressure Fault

1. Remove the 1/8" plug from the leak detection ball valve shown in Figure 5-1.
2. Install a 0 – 16" W.C. manometer (or W.C. gauge) where the 1/8" plug was removed.
3. Slowly open the leak detection ball valve
4. Start the unit in Manual mode at a valve position (firing rate) of 25%.
5. Slowly increase the gas pressure using the adjustment screw on the SSOV.
6. The unit should shut down and display a HIGH GAS PRESSURE fault message when the gas pressure exceeds 4.0" W.C. The FAULT indicator should also start flashing.
7. Reduce the gas pressure back to 2.8" W.C.
8. Press the CLEAR button on the Control Box to clear the fault.
9. The fault message should clear and the FAULT indicator should go off. The unit should restart.
10. Upon test completion, close the ball valve and remove the manometer. Replace the 1/8" plug removed in step 1.

## 5.4 LOW WATER LEVEL FAULT TEST

To simulate a low water level fault:

### Low Water Level Fault Test

1. Set the ON/OFF switch to the OFF position
2. Close the water shut-off valves in the supply and return piping to the unit.
3. Slowly open the drain valve on the rear of the unit. If necessary the unit's relief valve may be opened to aid in draining.
4. Continue draining the unit until a LOW WATER LEVEL fault message is displayed and the FAULT indicator flashes.
5. Place the unit in the Manual Mode and raise the valve position above 30%.
6. Set the ON/OFF switch to the ON position. The READY light should remain off and the unit should not start. If the unit does start, shut the unit off immediately and refer fault to qualified service personnel.
7. Close the drain and pressure relief valve used in draining the unit.
8. Open the water shut-off valve in the return piping to the unit.
9. Open the water supply shut-off valve to the unit to refill.
10. After the shell is full, press the LOW WATER LEVEL RESET button to reset the low water cutoff.
11. Press the CLEAR button to reset the FAULT LED and clear the displayed error message.
12. Set the ON/OFF switch to the ON position. The unit is now ready for operation.

## 5.5 WATER TEMPERATURE FAULT TEST

A high water temperature fault is simulated by adjusting the automatic over-temperature switch. This switch is accessible from the front of the unit as shown in Figure 5-2.

### Water Temperature Fault Test

1. Start the unit in the normal operating mode. Allow the unit to stabilize at its setpoint.
2. Lower the adjustable over-temperature switch setting to match the displayed OUTLET TEMPERATURE.
3. Once the adjustable over-temperature switch setting is approximately at, or just below, the actual outlet water temperature, the unit should shut down. The **FAULT** indicator should start flashing and a *HIGH WATER TEMP SWITCH OPEN* fault message should be displayed. It should not be possible to restart the unit.
4. Reset the adjustable over-temperature switch to its original setting.
5. The unit should start once the adjustable temperature limit switch setting is above the actual outlet water temperature.
6. Once the adjustable over-temperature switch setting is approximately at, or just below, the actual outlet water temperature, the unit should shut down. The **FAULT** indicator should start flashing and a *HIGH WATER TEMP SWITCH OPEN* fault message should be displayed. It should not be possible to restart the unit.
7. Reset the adjustable over-temperature switch to its original setting. The unit should start once the adjustable temperature limit switch setting is above the actual outlet water temperature.

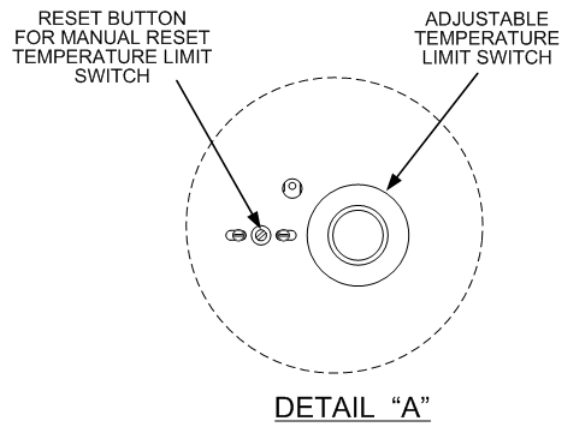
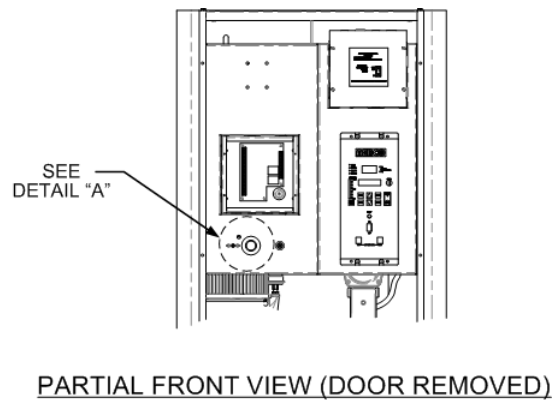

**Figure 5-2. Temperature Limit Switch Setting**

## 5.6 INTERLOCK TESTS

The unit is equipped with two interlock circuits called the Remote Interlock and Delayed Interlock. Terminal connections for these circuits are located in the I/O Box (Figure 2-9) and are labeled REMOTE INTL'K IN and DELAYED INTL'K IN. These circuits can shut down the unit in the event that an interlock is opened. These interlocks are shipped from the factory jumpered (closed). However, each of these interlocks may be utilized in the field as a remote stop and start, an emergency cut-off, or to prove that a device such as a pump, gas booster, or louver is operational.

### 5.6.1 Remote Interlock

#### Remote Interlock

1. Remove the cover from the I/O Box and locate the REMOTE INTL'K IN terminals.
2. Start the unit in the Manual Mode and set the valve position between 25% and 30%.
3. If there is a jumper across the REMOTE INTL'K IN terminals, remove one side of the jumper. If the interlock is being controlled by an external device, either open the interlock via the external device or disconnect one of the wires leading to the external device.
4. The unit should shut down and display INTERLOCK OPEN.
5. Once the interlock connection is reconnected, the INTERLOCK OPEN message should automatically clear and the unit should restart.

### 5.6.2 Delayed Interlock

#### Delayed Interlock

1. Remove the cover from the I/O Box and locate the DELAYED INTL'K IN terminals (see Figure 2-12).
2. Start the unit in the Manual Mode at a valve position between 25% and 30%.
3. If there is a jumper across the DELAYED INTL'K IN terminals, remove one side of the jumper. If the interlock is connected to a proving switch of an external device, disconnect one of the wires leading to the proving switch.
4. The unit should shut down and display a DELAYED INTERLOCK OPEN fault message. The FAULT LED should be flashing.
5. Reconnect the wire or jumper removed in step 3 to restore the interlock.
6. Press the CLEAR button to reset the fault.
7. The unit should start.

### 5.7 FLAME FAULT TESTS

Flame faults can occur during ignition or while the unit is already running. To simulate each of these fault conditions, proceed as follows:

#### Flame Fault Tests

1. Set the ON/OFF switch to the OFF position.
2. Place the unit in the Manual Mode and set the valve position between 25% and 30%.
3. Close the manual gas shutoff valve located between the Safety Shut-Off Valve (SSOV) and the Air/Fuel Valve (see Figure 5-3).
4. Set the ON/OFF switch to the ON position to start the unit.
5. The unit should shut down after reaching the Ignition cycle and display FLAME LOSS DURING IGN.
6. Open the valve previously closed in step 3 and press the CLEAR button.
7. Restart the unit and allow it to prove flame.
8. Once flame is proven, close the 1" manual gas shut-off valve located between the SSOV (Figure 5-3) and the Air/Fuel Valve.
9. The unit should shut down and execute an IGNITION RETRY cycle by performing the following:
  - (a) The unit will execute a shutdown purge cycle for a period of 15 seconds and display WAIT FAULT PURGE.
  - (b) The unit will execute a 30 second re-ignition delay and display WAIT RETRY PAUSE.
  - (c) The unit will then execute a standard ignition sequence and display WAIT IGNITION RETRY
10. Since the manual gas shutoff valve is still closed, the unit will shut down and display FLAME LOSS DURING IGNITION following the IGNITION RETRY cycle.
11. Open the valve previously closed in step 8.
12. Press the CLEAR button. The unit should restart and fire.

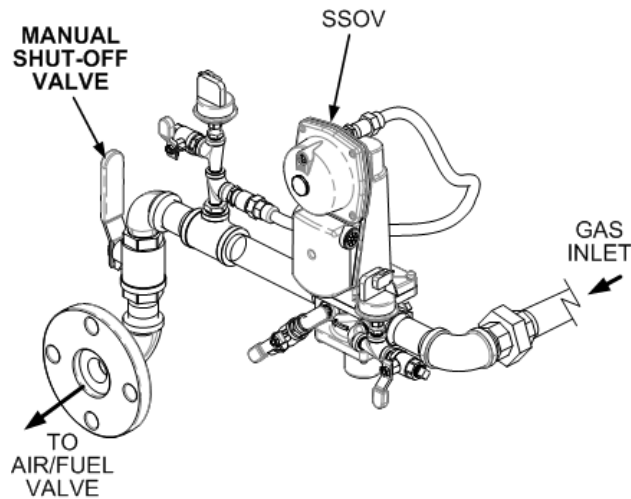

**Figure 5-3. Manual Gas Shut-Off Valve Location (INN1060 Gas Train)**

## 5.8 AIR FLOW FAULT TESTS

These tests check the operation of the Blower Proof Switch and Blocked Inlet Switch shown in Figure 5-4.

### Air Flow Fault Tests

1. Disable the blower output drive voltage as follows:
  - (a) Press the MENU key until CONFIGURATION MENU is displayed.
  - (b) Press the ▲ arrow key until the ANALOG OUTPUT function is displayed, then press the CHANGE key.
  - (c) Press the ▼ arrow key until OFF is displayed, then press the ENTER key.
2. Start the unit in the Manual Mode at a valve position of 25%.
3. The unit should shut down and execute an IGNITION RETRY cycle by performing the following steps:
  - (a) The unit will execute a 30 second re-ignition delay and display WAIT RETRY PAUSE.
  - (b) The unit will then execute a standard ignition sequence and display WAIT IGNITION RETRY.
4. The unit should perform two IGNITION RETRY cycles and then shut down on the third successive ignition attempt. The unit will display AIRFLOW FAULT DURING PURGE.
5. Re-enable the blower output drive voltage by performing the following steps:
  - (a) Press the MENU key until CONFIGURATION MENU is displayed.
  - (b) Press the ▲ arrow key until the ANALOG OUTPUT function is displayed, then press the CHANGE key.
  - (c) Press the ▲ arrow key until VALVE POSITION 0-10V is displayed, then press the ENTER key.
6. Once the unit has proved flame, turn off the blower by going to the Configuration Menu, Analog Output menu item and select OFF.



**Air Flow Fault Tests - Continued**

1. The Blower Proof Switch will open and the blower should stop. The unit should shut down and display AIRFLOW FAULT DURING RUN.
2. Go to the Configuration Menu, Analog Output item and select VALVE POSITION 0-10v.
3. Press the CLEAR button. The unit should restart.
4. Next, check the operation of the Blocked Inlet Switch located on the inlet side of the Air/Fuel Valve (Figure 5-4).
5. Ensure that the sheet metal panels are securely installed on the water heater and the unit is running.
6. At the rear of the unit, partially block the air inlet (Figure 5-5) with a plywood sheet or metal plate.
7. The unit should shut down and again display AIRFLOW FAULT DURING RUN.
8. Unblock the air inlet and press the CLEAR button. The unit should restart.

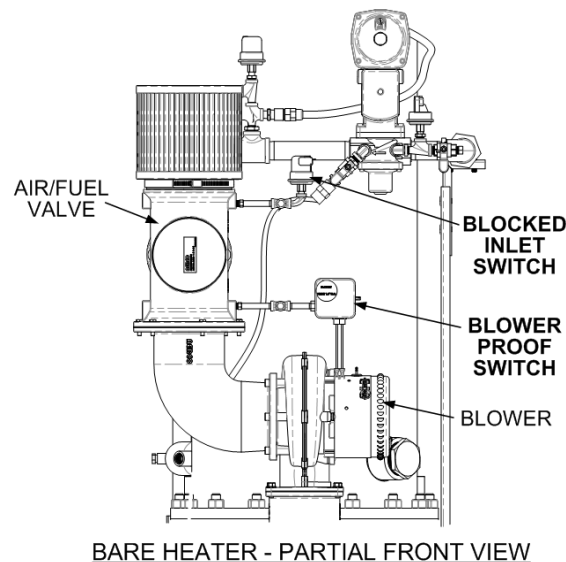

**Figure 5-4. Blower Proof & Blocked Inlet Switch Locations**

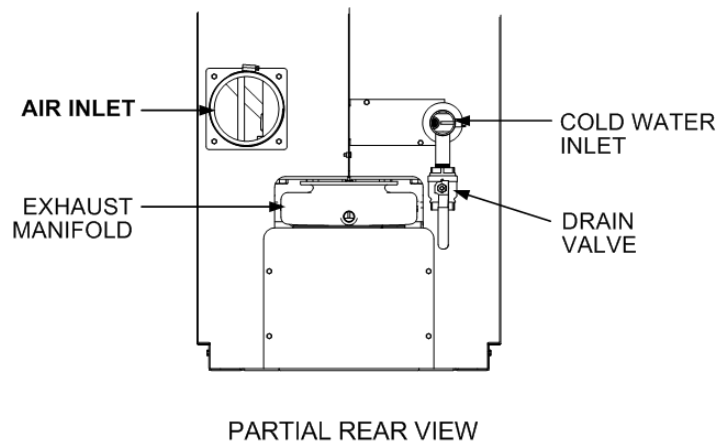

**Figure 5-5. Water Heater Rear View Showing Air Inlet Location**

## 5.9 SSOV PROOF OF CLOSURE SWITCH

The SSOV shown in Figure 5-1 contains the proof of closure switch. The proof of closure switch circuit is checked as follows:

### SSOV Proof of Closure Switch

1. Set the unit's ON/OFF switch to the OFF position.
2. Place the unit in Manual Mode and set the valve position between 25% and 30%.
3. Refer to Figure 5-1 and locate the SSOV.
4. Remove the cover from the SSOV by loosening the screw shown in Figure 5-6. Lift off the cover to access the terminal wiring connections.
5. Disconnect wire #148 from the SSOV to "open" the proof of closure switch circuit.
6. The unit should fault and display SSOV SWITCH OPEN.
7. Replace wire #148 and press the CLEAR button.
8. Set the ON/OFF switch to ON to start the unit.
9. Remove the wire again when the unit reaches the purge cycle and PURGING is displayed.
10. The unit should shut down and display SSOV FAULT DURING PURGE.
11. Replace the wire on the SSOV and press the CLEAR button. The unit should restart.

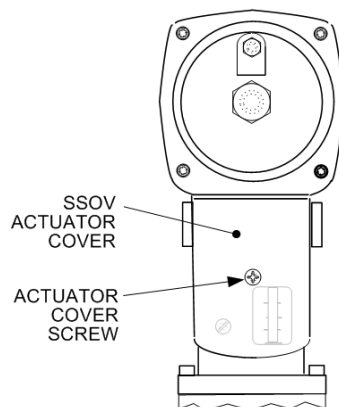

**Figure 5-6. SSOV Actuator Cover Location**

### 5.10 PURGE SWITCH OPEN DURING PURGE

The Purge Switch (and Ignition Switch) is located on the Air/Fuel Valve. To check the switch, proceed as follows:

#### Purge Switch Open During Purge

1. Set the unit's ON/OFF switch to the OFF position. Place the unit in manual mode and set the valve position between 25% and 30%.
2. Remove the Air/Fuel Valve cover by rotating the cover counterclockwise to unlock it (see Figure 5-7).
3. Remove one of the two wires (#171 or #172) from the Purge Switch (Figure 5-8).
4. Initiate a unit start sequence.
5. The unit should begin its start sequence, then shut down and display PRG SWITCH OPEN DURING PURGE.
6. Replace the wire on the Purge Switch and depress the CLEAR button. The unit should restart.

### 5.11 IGNITION SWITCH OPEN DURING IGNITION

The Ignition Switch (and the Purge Switch) is located on the Air/Fuel Valve. To check the switch, proceed as follows:

#### Ignition Switch Open During Ignition

1. Set the unit's ON/OFF switch to the OFF position.
2. Place the unit in Manual Mode and set the valve position between 25% and 30%.
3. Remove the Air/Fuel Valve cover (Figure 5-5) by rotating the cover counterclockwise to unlock and lift up to remove.
4. Remove one of the two wires (#169 or #170) from the Ignition Switch (Figure 5-8).
5. Initiate a unit start sequence.
6. The unit should begin its start sequence and then shut down and display IGN SWITCH OPEN DURING IGNITION.
7. Replace the wire on the Ignition Switch and press the CLEAR button. The unit should restart.

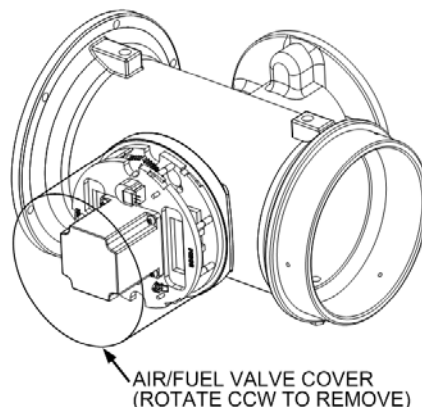

**Figure 5-7. Typical Air/Fuel Valve Cover Location**

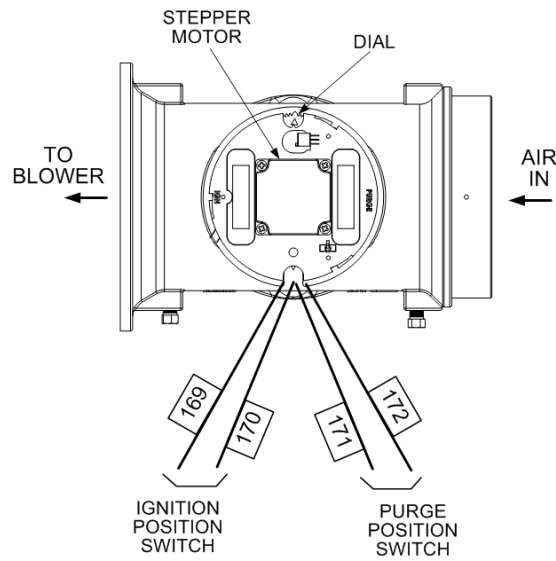

**Figure 5-8. Air/Fuel Valve Purge and Ignition Switch Locations**

### 5.12 SAFETY PRESSURE RELIEF VALVE TEST

Test the safety Pressure Relief Valve in accordance with ASME Pressure Vessel Code, Section VI.

## CHAPTER 6 MAINTENANCE

### 6.1 MAINTENANCE SCHEDULE

The Innovation Water Heater requires regular routine maintenance to ensure continued reliable operation throughout the service life of the unit. For optimum operation, AERCO recommends that the following routine maintenance procedures be performed in the time periods specified in Table 6-1.

Appendix I contains a list of the recommended spare parts for maintenance of the Innovation Heater.

### **WARNING**

TO AVOID PERSONAL INJURY, PRIOR TO SERVICING ENSURE THAT THE FOLLOWING GUIDELINES ARE STRICTLY OBSERVED:

- DISCONNECT THE AC SUPPLY BY TURNING OFF THE SERVICE SWITCH AND AC SUPPLY CIRCUIT BREAKER.
- SHUT OFF THE GAS SUPPLY AT THE MANUAL SHUT-OFF VALVE PROVIDED WITH THE UNIT
- ALLOW THE UNIT TO COOL TO A SAFE WATER TEMPERATURE TO PREVENT BURNING OR SCALDING

**TABLE 6-1 - MAINTENANCE SCHEDULE**

PARAGRAPH	ITEM	6 Mos.	12 Mos.	24 Mos.	Labor Time
6.2	Igniter-Injector (58023)	* Inspect	Inspect	Replace	15 mins.
6.3	Flame Detector (66018)	* Inspect	Inspect	Replace	15 mins.
6.4	Combustion Calibration	* Check	Check		1 hr.
6.5	Testing of Safety Devices		Test		20 mins.
6.6	Fireside Inspection			Inspect & Clean	2 hrs.
6.7	Waterside Inspection	* Inspect		Inspect	1 hr.
6.8	Heat Exchanger Cleaning		Inspect & Clean (as required)		2 hrs.
6.9	Condensate Drain Trap	* Inspect	Inspect & Clean		30 mins.
6.10	Air Filter (59138)		Clean or Replace		5 mins.

\* Only performed after initial 6 month period after initial startup.

## 6.2 IGNITER-INJECTOR

Currently, two different types of igniters are used with Innovation Water Heaters. Heater Models INN600, INN800 and INN1060 utilize igniter-injector part no. 58023. However Innovation Heater Model INN1350 utilizes igniter, part no. 66023.

Since differences exist in the removal/replacement of these two igniters, separate procedures are provided for each type. For Model INN600, INN800 and INN1060 units, refer to paragraph 6.2.1 (igniter-injector part no. 58023). For Model INN1350 units, refer to paragraph 6.2.2 (igniter part no. 66023).

### 6.2.1 Igniter-Injector Part No. 58023

The igniter-injector (part no. 58023) is currently used on all IN600, INN800 and INN1060 units. The igniter-injector is located on the flange of the blower-side intake manifold located at the bottom of the unit's heat exchanger. In addition to providing the ignition spark required to light the burner, the igniter-injector also contains a gas injector tube which connects to the staged ignition assembly. Figure 6-1 shows the blower-side intake manifold removed from the heater and indicates the locations of the igniter-injector, flame detector and other related components.

The igniter-injector may be hot, therefore, care should be exercised to avoid burns. It is easier to remove the igniter-injector from the unit after the unit has cooled to room temperature. Inspect/replace the Igniter-Injector as described below.

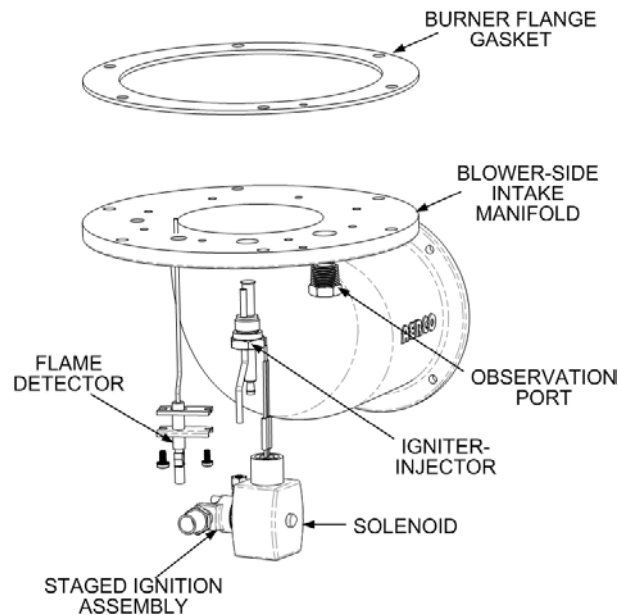
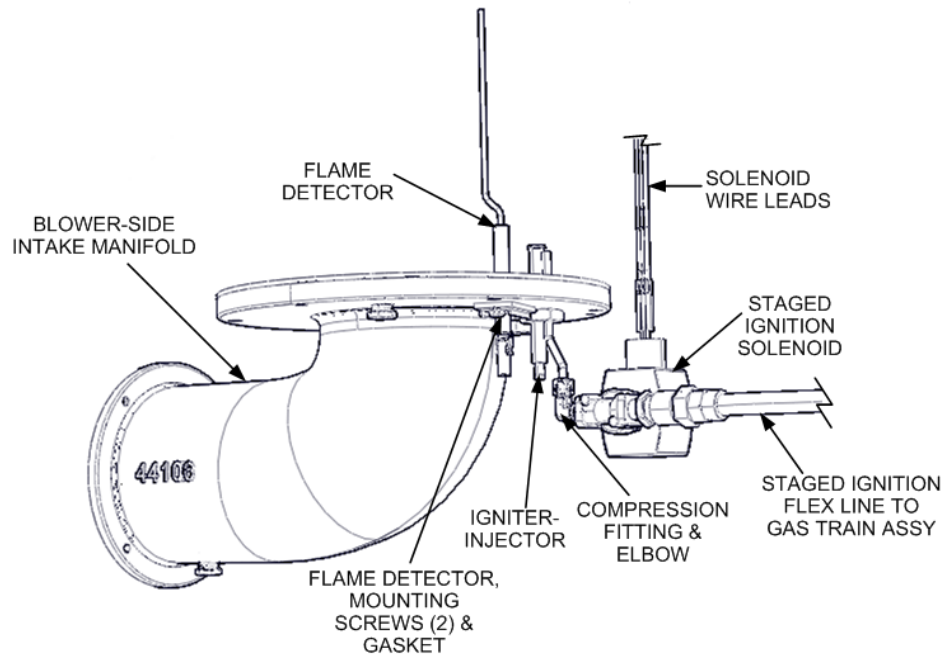

**Figure 6-1. Blower-Side Intake Manifold (With Igniter-Injector Part No. 58023)**

#### **58023 Igniter-Injector Inspection/Replacement**

1. Set the ON/OFF switch on the control panel, to the OFF position. Disconnect AC power from the unit
2. Remove the side and rear panels from the unit.
3. Disconnect the cable from the igniter-injector (Figure 6-1).
4. Refer to the partial exploded view in Figure 6-1 and Figure 6-2. Using a 7/16" open-end wrench, disconnect the compression nut securing the gas injector tube of the igniter-injector to the elbow of the staged ignition solenoid assembly. Disconnect the staged ignition assembly from the igniter-injector.

**58023 Igniter-Injector Inspection/Replacement - Continued**



**Figure 6-2. Igniter-Injector (58023) & Flame Detector Mounting Details**

5. Next, loosen and remove the igniter-injector from the intake manifold flange using a 1" open-end wrench.
6. Check the igniter-injector for evidence of erosion or carbon build-up. If there is evidence of substantial erosion or carbon build-up, the igniter-injector should be replaced. If carbon build-up is present, clean the component using fine emery cloth. Repeated carbon build-up is an indication that the combustion settings of the unit should be checked. Refer to Chapter 4 for combustion calibration procedures.
7. Prior to reinstalling the igniter-injector, a high temperature, conductive, anti-seize compound must be applied to the threads.

**NOTE**

If a replacement igniter-injector (part no. 58023) is being installed, a compression nut containing a built-in ferrule will be included with the replacement part. If needed, 3 indexing washers are also included. These washers may be needed to properly position the gas injector tube of the igniter-injector so it does not contact other components or assemblies of the unit.

8. Reinstall the igniter-injector on the intake manifold flange. Torque to 15 ft-lbs. Do not over tighten.
9. Connect the staged ignition assembly to the gas injector tube of the igniter-injector by securing the compression nut to the elbow of the staged ignition assembly.
10. Reconnect the igniter-injector cable.
11. Reinstall the side and rear panels on the unit.

### 6.2.2 Igniter Part No. 66023

The igniter (66023) used on Innovation Model INN1350 units is also located on the flange of the blower-side intake manifold located at the bottom of the unit's heat exchanger. Figure 6-3 shows the blower-side intake manifold removed from the heater and indicates the locations of the igniter, flame detector and other related components.

The igniter may be hot, therefore, care should be exercised to avoid burns. It is easier to remove the igniter from the unit after the unit has cooled to room temperature.

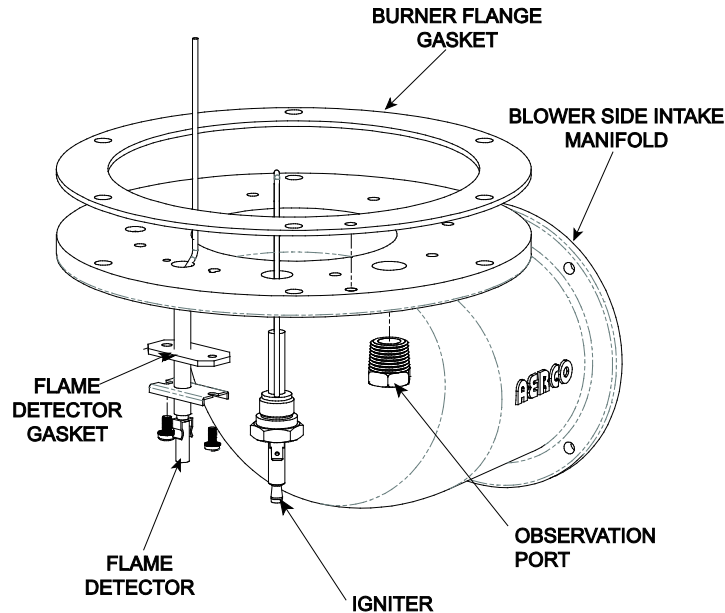

**Figure 6-3. Blower-Side intake Manifold (With Igniter Part No. 66023)**

To inspect/replace the Igniter:

#### 66023 Igniter Inspection/Replacement

1. Set the ON/OFF switch on the control panel, to the OFF position. Disconnect AC power from the unit.
2. Remove the side and rear panels from the unit.
3. Disconnect the cable from the igniter.
4. Next, loosen and remove the igniter from the intake manifold flange using a 1" open-end wrench.
5. Check the igniter for evidence of erosion or carbon build-up. If there is evidence of substantial erosion or carbon build-up, the igniter should be replaced. If carbon build-up is present, clean the component using fine emery cloth. Repeated carbon build-up is an indication that the combustion settings of the unit should be checked. Refer to Chapter 4 for combustion calibration procedures.
6. Prior to reinstalling the igniter, a high temperature, conductive, anti-seize compound must be applied to the threads.



**68023 Igniter Inspection/Replacement - Continued**

7. Refer to Figure 6-4 and reinstall the igniter on the intake manifold flange. Torque to 15 ft-lbs. Do not over tighten.

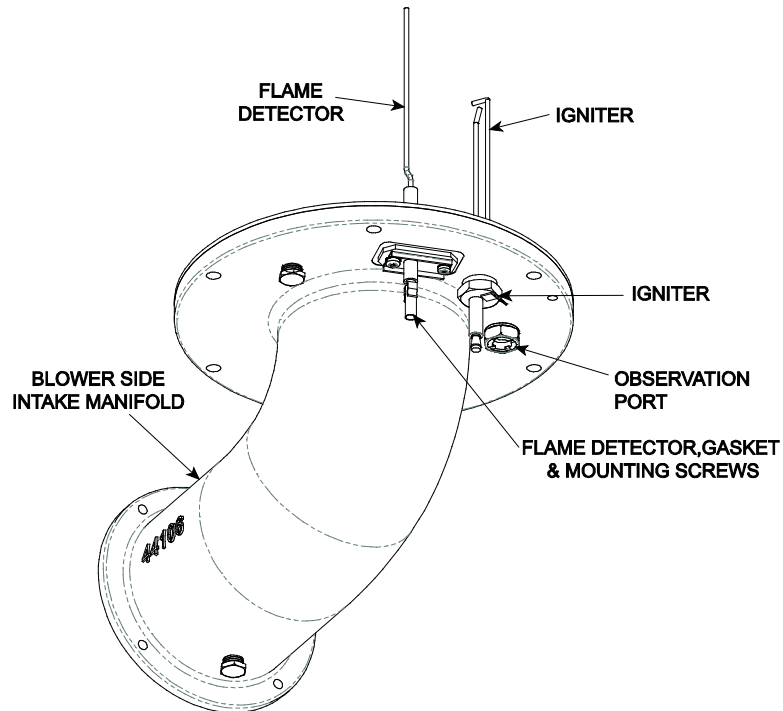

**Figure 6-4. Igniter & Flame Detector Mounting Details**

8. Reconnect the igniter-injector cable.
9. Reinstall the side and rear panels on the unit.

### 6.3 FLAME DETECTOR

Flame detector (part no. 66018) is used on ALL Innovation Water Heater Models. The flame detector is also located on the flange of the blower-side intake manifold as shown in Figures 6-1 through and 6-4. The flame detector may be hot. Allow the unit to cool sufficiently before removing the flame detector. To inspect or replace the flame detector:

#### 66018 Flame Detector Inspection/Replacement

1. Set the ON/OFF switch on the control panel, to the OFF position. Disconnect AC power from the unit.
2. Remove the side and rear panels from the unit.
3. Disconnect the flame detector lead wire.
4. Remove the two (2) screws securing the flame detector to the intake manifold (Figures 6-1 through 6-4). The flame detector is secured to the burner intake manifold with one (1) #10-32 screw and one (1) #8-32 screw.
5. Remove the flame detector and gasket from the manifold flange.
6. Thoroughly inspect the flame detector. If eroded, the detector should be replaced. Otherwise, clean the detector with a fine emery cloth.
7. Reinstall the flame detector and flame detector gasket.
8. Reconnect the flame detector lead wire.
9. Reinstall the side and rear panels on the unit.

### 6.4 COMBUSTION CALIBRATION

Combustion settings must be checked at the intervals shown in Table 6-1 as part of the maintenance requirements. Refer to Chapter 4 for combustion calibration instructions.

### 6.5 SAFETY DEVICE TESTING

Systematic and thorough tests of the operating and safety devices should be performed to ensure that they are operating as designed. Also, certain code requirements specify that these tests be performed on a scheduled basis. Test schedules must conform to local jurisdictions. The results of the tests should be recorded in a log book. See Chapter 5 for Safety Device Test Procedures.

### 6.6 FIRESIDE INSPECTION

Fireside inspection of the Innovation Water Heater will include removal of the exhaust manifold, Blower-side intake manifold, and the burner assembly from the Innovation Water Heater.

The purpose of this inspection is to check for the formation of deposits on the inside of the heat exchanger tubes, exhaust manifold, and/or the burner assembly. These deposits can be caused by the presence of even trace amounts of chlorides and/or sulfur, in the combustion air and fuel sources. Such deposits can be influenced by the extent of the condensing operation and the chloride and sulfur levels that can vary significantly from application to application.

Since the fireside inspection will include removal of the exhaust manifold, burner assembly and blower-side intake manifold from the Innovation Water Heater, the following replacement gaskets will be necessary for reassembly upon completion of the inspection:

<u>Part No.</u>	<u>Description</u>
18899	Burner Flange Gasket
81048	Flame Detector Gasket
18899	Burner Gasket
124749	Fiber Frax Gasket
161151	Combustion Chamber Liner (If damaged)

The blower-side intake manifold may be hot. Therefore, allow the unit to cool sufficiently before starting the removal process described in the following steps

### **Fireside Inspection**

1. Set the **ON/OFF** switch on the control panel, to the **OFF** position. Disconnect AC power from the unit and turn off the gas supply.
2. Remove the side and rear panels from the unit.
3. Refer to Figures 6-5 and 6-6 to locate the blower-side intake manifold (part no. 44106) at the bottom of the unit's heat exchanger.
4. Disconnect the lead wire from the flame detector installed on the intake manifold flange (Figure 6-2).
5. Remove the two (2) screws securing the flame detector to the blower-side intake manifold (24234). The flame detector is secured to the manifold with one (1) #10-32 screw and one (1) #8-32 screw.
6. Remove the flame detector and gasket from the blower side intake manifold flange.
7. Disconnect the cable from the igniter-injector which is also installed on the blower-side intake manifold flange.
8. For INN 600, 800 and 1060 units, the gas injector tube must be disconnected from the igniter-injector. Using a 7/16" open-end wrench, disconnect the compression nut securing the gas injector tube of the igniter-injector to the elbow of the staged ignition assembly (see Figure 6-2). Disconnect the staged ignition assembly from the igniter-injector.
9. Next, loosen and remove the igniter-injector (or igniter 66023) from the intake manifold flange using a 1" open-end wrench.
10. Refer to Figure 6-5. Loosen and remove the four (4) 1/4-20 cap screws securing the blower side of the intake manifold (44106). **DO NOT REMOVE** the two 1/4-20 screws and nuts securing the manifold support bracket.

**Fireside Inspection - Continued**

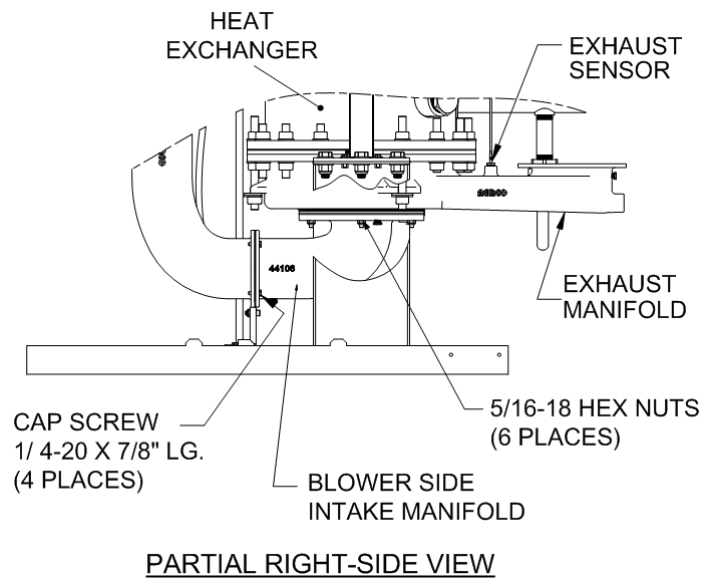
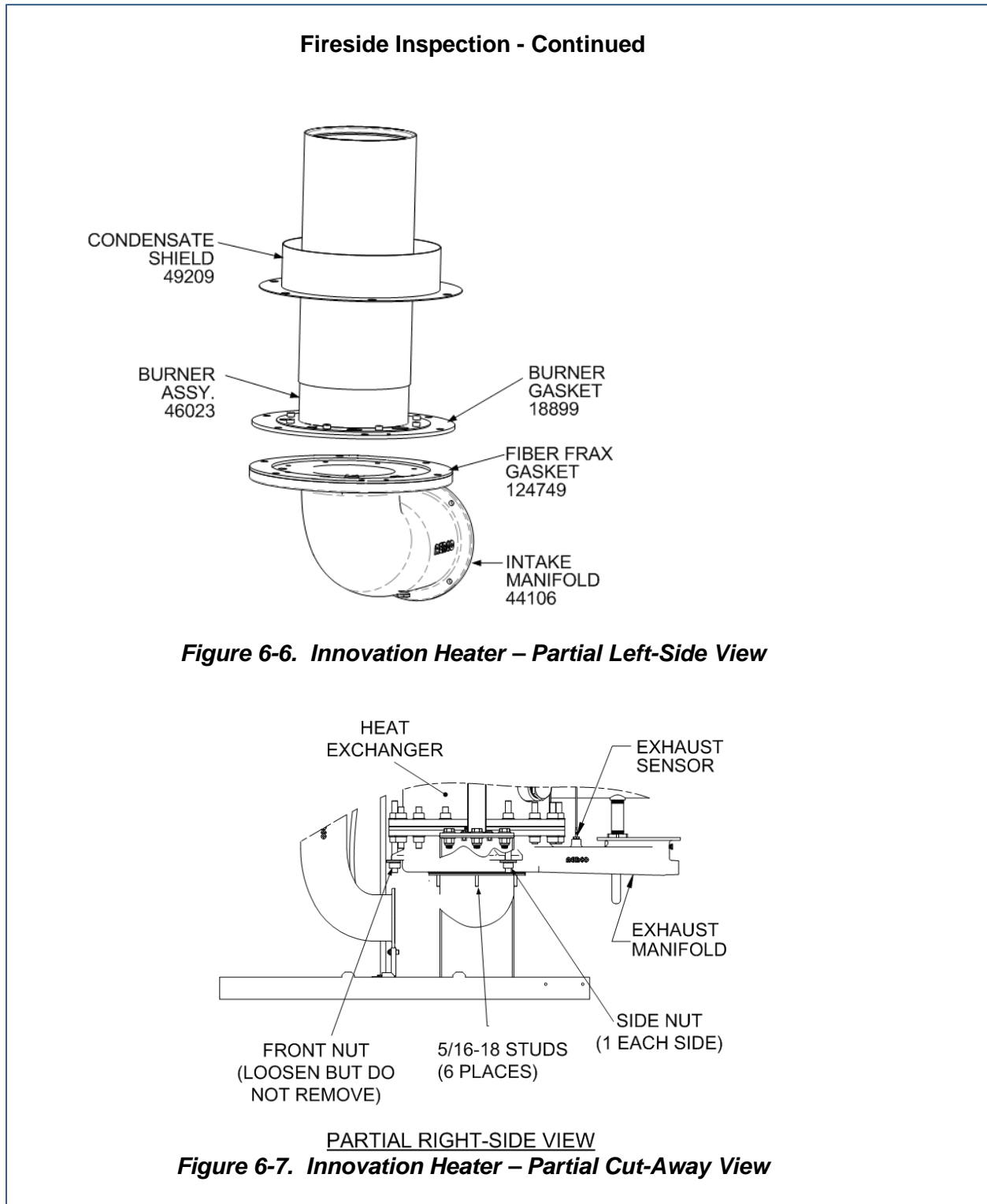

**Figure 6-5. Blower-Side Intake Manifold & Exhaust Manifold Locations**

**⚠ CAUTION ⚠**

The intake manifold, burner and exhaust manifold assemblies weigh approximately 25 pounds. Use care when removing these assemblies in the following steps.

11. While supporting the blower-side intake manifold, loosen and remove the six (6) 5/16-18 hex nuts securing it to the studs protruding from the exhaust manifold.
12. Carefully lower and remove the blower side intake manifold (44106), burner assembly (46023), burner gasket (18899) and fiber frax gasket (124749) from the unit. See Figures 6-3 and 6-4.
13. Disconnect the exhaust temperature sensor (Figure 6-3) by unscrewing it from the exhaust manifold.
14. While supporting the exhaust manifold, remove the two (2) side nuts (Figure 6-7) securing the manifold to the heat exchanger. Loosen, but **DO NOT REMOVE** the third nut nearest to the front of the unit.
15. Remove the exhaust manifold (44085) from the unit.
16. Inspect the exhaust manifold and burner assemblies for debris. Clean out debris as necessary.
17. Using a flashlight, inspect the combustion chamber liner (161151) shown in Figure 6-8. Replace the liner if there is evidence of cracking or warping.
18. This completes the fireside inspection of the unit. Proceed to step 19 and reassemble the unit as indicated.



**Fireside Inspection – Continued**

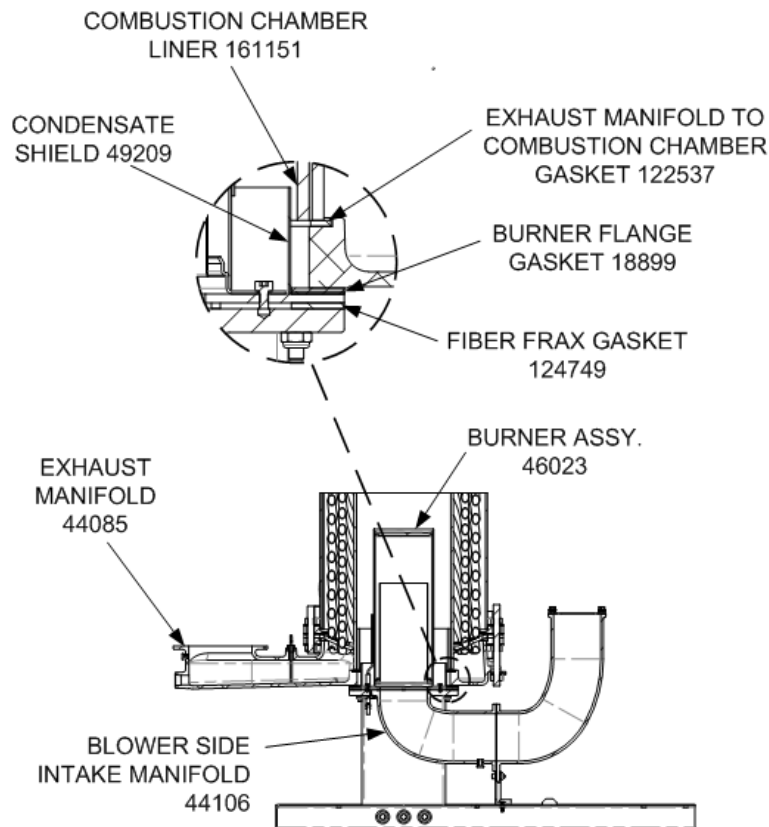

**Figure 6-8. Combustion Chamber Liner & Gasket Locations**

**IMPORTANT**

Prior to reassembly, ensure that the combustion chamber liner is installed before reinstalling the exhaust manifold.

During reassembly, apply high-temperature, anti-seize lubricant to the threads of the igniter-injector and grounding screw. Also, ensure that the igniter-injector and staged ignition assembly are properly positioned and are not contacting other components. Torque the igniter-injector to 15 ft-lbs.

19. Beginning with the exhaust manifold assembly removed in step 15, reinstall all the components in the reverse order that they were removed.

## 6.7 WATERSIDE INSPECTION

The waterside of the heating surfaces may be inspected by removal of the top heater head. (See Figure 6-9). Prior to performing the inspection, ensure that the following replacement gaskets are available:

- GP-18556 Release Gasket
- GP-18532 Shell Gasket

To inspect the waterside of the heat exchanger, proceed as follows:

### **Waterside Inspection**

1. Disconnect the electrical power to the unit.
2. Close the water inlet, outlet, and recirculation shut-off valves to the unit.
3. Carefully open the drain valve while opening the relief valve on the rear of the unit to relieve pressure and allow air into the shell.
4. Remove the wing nut from the top center of the shell cap and remove the cap.
5. Remove the nuts and cap screws from the upper head. Remove the upper head and upper head-liner, (See Figure 6-9).
6. Inspect and clean the heat exchanger tubes of scale and all gasket surfaces thoroughly before reassembling the upper head. AERCO recommends that NEW gaskets be used when reassembling.
7. Place a shell head gasket on top of the shell ring first, then place the release gasket on top of the shell head gasket. Align the gasket holes with those in the shell ring.
8. Place the upper head liner on top of the gaskets.
9. Place the upper head on next aligning the holes.
10. Reassemble the cap screws and nuts through the upper head and shell ring. Cross tighten the nuts to approximately 75 ft.-lb. torque to obtain a uniform seating, then progressively tighten the nuts to 150 ft.-lb.
11. Replace the unit Cap. Close the drain valve and reopen the inlet, outlet, and recirculation valve.

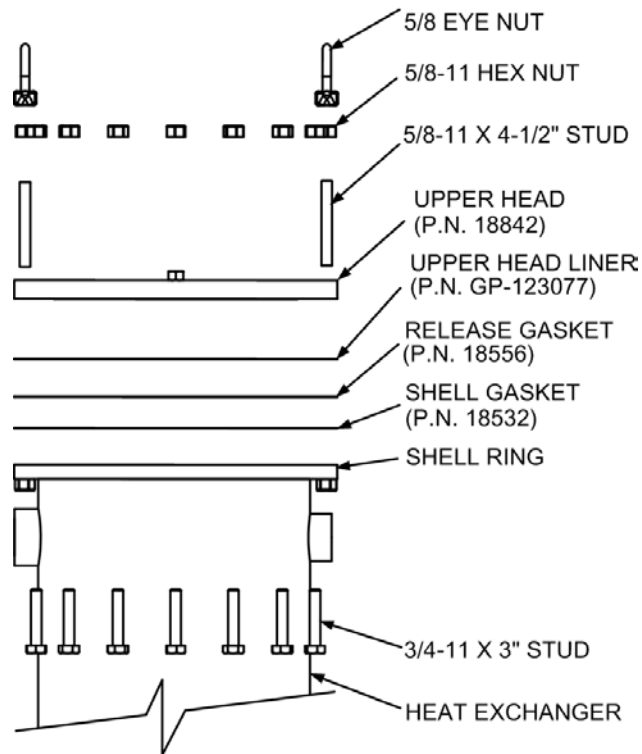

**Figure 6-9. Flat Style Head Configuration**



## 6.8 HEAT EXCHANGER CLEANING

AERCO recommends that the heat exchanger of the unit be cleaned annually to maintain maximum heat transfer efficiencies using a solution of Hydroskrub and water. Hydroskrub is distributed by AERCO International, Inc. and is designed to dissolve the toughest water scale, lime, mud and rust deposits from virtually any type of water-based equipment.



Please review MSDS, specifications, and our website ([www.aerco.com](http://www.aerco.com)) for additional information, or call technical service at (800) 526-0288.



Do not drain the unit without venting the shell! A vacuum in the unit may displace the head liner causing serious damage not covered by warranty.

### 6.8.1 Pumping System Set-Up Instructions

A sample pumping set-up diagram is shown in Figure 6-8 for an Innovation Water Heater. As this diagram shows, heat exchanger cleaning is accomplished by pumping the HydroSkrub solution from a large circulating bucket to the heat exchanger drain valve, through the heat exchanger and then out through the output connection of the heater. Set up the pumping system as follows:

#### Set-Up Instructions

1. Turn off the water heater and close the inlet and outlet isolation valves.
2. Open the drain valve at the rear of the heater and drain at least half of the heat exchanger water-side volume. When full Innovation models hold approximately the gallons of water listed below:
  - INN600: 24.5 gallons (drain at least 12.25 gallons)
  - INN800 24.5 gallons (drain at least 12,25 gallons)
  - INN1060: 23 gallons (drain at least 11.5 gallons)
  - INN1350 20.6 gallons (drain at least 10.3 gallons)

For the Innovation model being cleaned, drain at least the amount of eater shown in parentheses.

3. Prepare a 50% solution of Hydroskrub and clean water. The amount of the solution should be approximately equal to the full volume of water that the heat exchanger holds.
4. Mix 11 gallons of HydroSkrub with 11 gallons of water to provide a 50% solution.
5. Close the unit drain valve and connect a suitable size bucket and pump to the unit drain as shown in Figure 6-8.
6. Install a "T", ball valve and hose connection in the outlet piping of the heater (Figure 6-8). Route the hose back to the top of the circulation bucket.

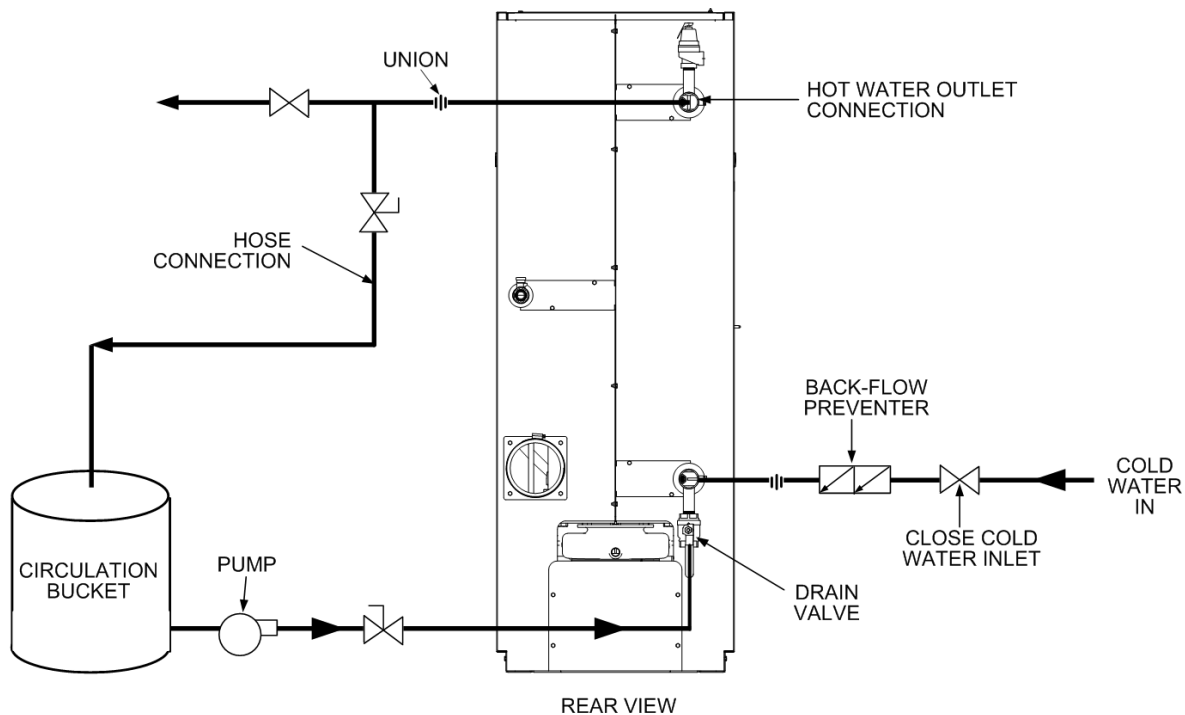

**Figure 6-8. Sample Heat Exchanger Cleaning Set-Up**

## 6.8.2 Cleaning Procedure

### Cleaning Procedure

1. Slowly add the prescribe amount of the Hydroskrub solution to the circulating bucket.
2. Open the drain valve, outlet hose connection valve and turn on the pump. Periodically check for leaks and maintain the liquid level in the bucket. A lowering volume level is an indication that there is an open drain in the system.
3. Check the cleaning circuit to ensure that the HydroSkrub solution is flowing from the circulation bucket, through the pump and the heater and back to the top of the top of the bucket.
4. Return discharge foaming indicates an active HydroSkrub solution and the presence of mineral deposits in the equipment.
5. Additional HydroSkrub and/or water may be required to maintain circulation and to prevent the pump from cavitating.
6. Circulate the cleaning solution through the heat exchanger and piping for 1 to 3 hours. Estimate the circulation period based on the time in service and water hardness. When the foaming action stops, HydroSkrub strength is depleted (two pounds of deposits removed per gallon used) or the equipment is free from calcium and other water-formed mineral deposits.
7. Periodically test the solution for effectiveness to determine if more HydroSkrub is needed. Refer to "Testing HydroSkrub Effectiveness" in the next paragraph for details. If the cleaning solution is expended before circulation time is up, additional HydroSkrub will be needed and circulation time may be extended to complete the cleaning.
8. Upon completion of the cleaning process, begin flushing the solution by adding clean water to the circulation bucket, then disconnect the return valve and hose connection from the top of the circulating bucket and thoroughly flush. Continue water flushing the equipment for a minimum of 10 minutes or until discharge runs clear.

**Cleaning Procedure - Continued**

9. HydroSkrub is biodegradable, and in most instances may be purged down sewers. Check with local authorities before disposing of any complex compositions
10. Turn off water, shut off the pump and immediately close discharge valves to prevent backflow.
11. Completely drain pump bucket. Disconnect the hoses from equipment and thoroughly rinse the bucket, pump, and associated hoses used.

**6.8.3 Testing HydroSkrub Effectiveness**

There are two methods of testing the effectiveness of HydroSkrub during cleaning: the calcium carbonate spot test of the circulating solution and the charting of a trend in the pH of the cleaning solution.

**Calcium Carbonate Spot Test**

A calcium carbonate spot test is performed by exposing a form of calcium carbonate to the HydroSkrub solution. Samples of the deposit, a Tums or Roloids tablet, or bare concrete can be used. Observe the reaction of the HydroSkrub solution on the calcium carbonate. Foaming and bubbling indicates the solution is still active. Little or no reaction indicates that the solution is expended. This test should be performed near the end of the circulating time. If the solution has been expended, more HydroSkrub will be required to complete the job. If the solution is still active at the end of the time, all the scale has been dissolved.

**pH Trend Charting**

The initial pH of the cleaning solution will measure between 1-3 (See pH sheet on HydroSkrub packaging). To test the effectiveness of the circulating solution as a function of pH, take readings at regular intervals and chart as a trend. Note that the deposits can cause a premature jump in the pH. After circulating for approximately 75% of the cycle time, begin testing the pH at 10-15 minute intervals. Once the solution's pH reads 6.0-7.0 on three or more consecutive readings, the solution is expended. If the pH reads below 6.0 after the circulating time, the application is clean.

**6.9 CONDENSATE DRAIN TRAP**

The Innovation Water Heater contains a condensate trap as shown in Chapter 2, Figure 2-7. The trap is located external to the unit and attached to the drain connection from the exhaust manifold. This trap should be inspected and, if necessary, cleaned to ensure proper operation.

Currently, two styles of the condensate traps are in use. Both styles perform the same functions and contain identical internal floats. However, the older style has a separate inlet adapter and the newer style contains a built-in adapter. Refer to Figure 6-9. Maintenance tasks for both styles are basically identical, however the newer style does not require an orifice gasket.

To inspect and clean the trap, proceed as follows:

**Condensate Trap Inspection and Cleaning**

1. Disconnect the external condensate trap by loosening the union pipe connection between the trap and the exhaust manifold drain.
2. Remove the connections on the inlet and outlet sides of the condensate trap shown in Figure 6-9.
3. Loosen the four (4) thumbscrews securing the cover on the condensate trap. Remove the cover.
4. Remove the float from the condensate trap.
5. For older style condensate traps, remove the orifice gasket shown in Figure 6-9.

**Condensate Trap Inspection and Cleaning - Continued**

6. Thoroughly clean the trap, float and orifice gasket (if so equipped). Also inspect the drain piping for blockage. If the trap cannot be thoroughly cleaned, replace the trap.
7. After the above items have been thoroughly cleaned and inspected, replace the orifice gasket (older style only) and the float in the condensate trap and replace the trap cover.
8. Reassemble all piping and hose connections to the condensate trap inlet and outlet. Reconnect the trap to exhaust manifold drain.

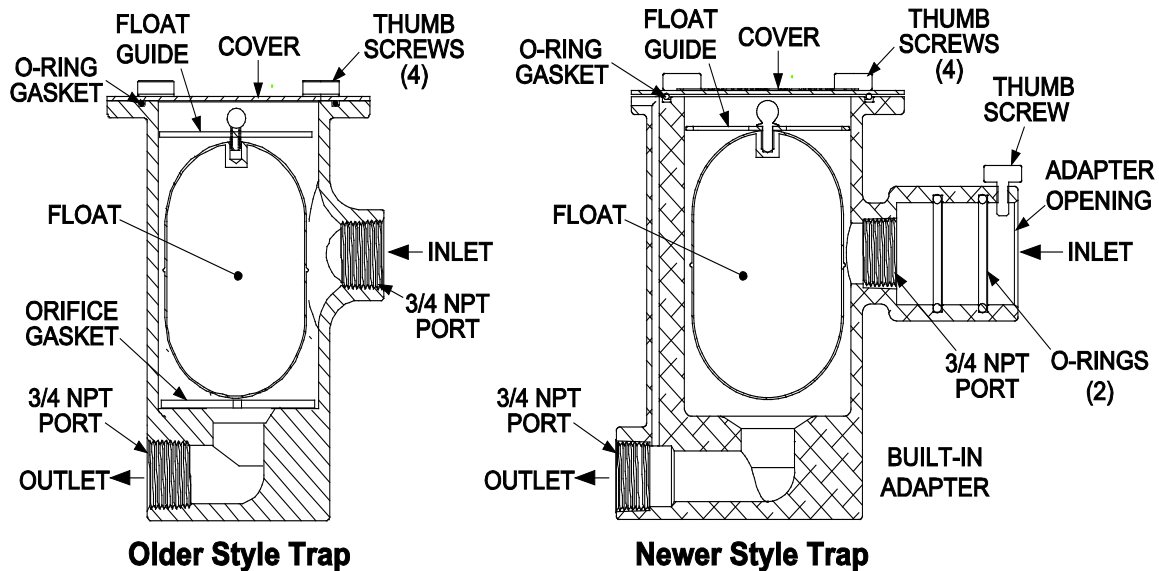

**Figure 6-9. External Condensate Trap**

**6.10 AIR FILTER REPLACEMENT**

The Innovation heater is equipped with an air filter (part no. 59138) which should be cleaned or replaced every 12 months. The air filter is located at the inlet of the air fuel valve as shown in Figure 6-10.

To inspect/replace the air filter, proceed as follows:

**Air Filter Replacement**

1. Set the ON/OFF switch on the control panel, to the OFF position. Disconnect AC power from the unit
2. Remove the side panels from the unit.
3. Refer to Figure 6-10 and locate the air filter attached to the air/fuel valve inlet.
4. Using a flat-tip screwdriver or 5/16" nut driver, loosen the clamp securing the filter to the inlet flange of the air/fuel valve. Remove the filter and clamp.
5. Each replacement air filter is equipped with its own clamp. Therefore, simply install the replacement air filter on inlet flange of the air fuel valve and tighten the clamp with a flat-tip screwdriver or 5/16" nut driver.
6. Replace the side panels on the unit and return heater to service use.

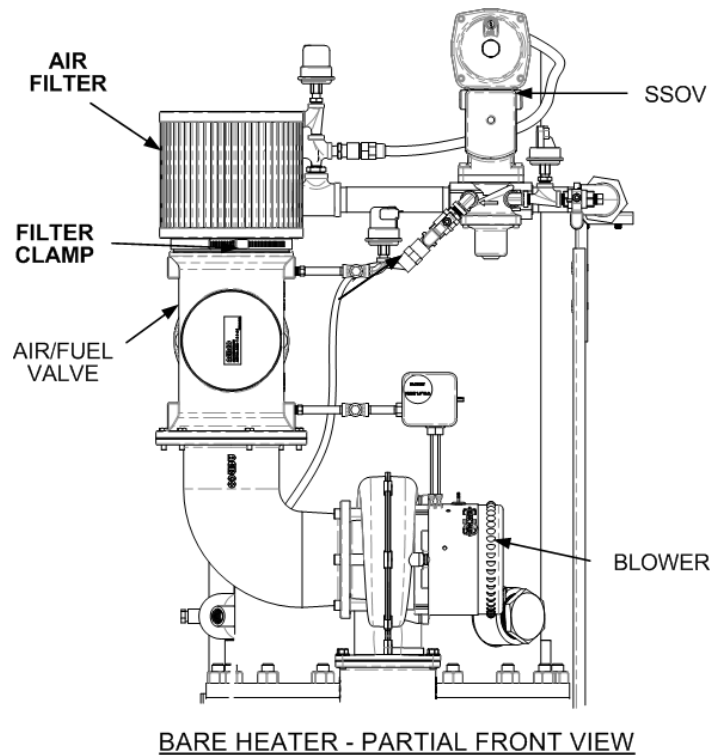

**Figure 6-10. Air Filter Mounting Location**

### 6.11 SHUTTING THE WATER HEATER DOWN FOR AN EXTENDED PERIOD OF TIME

If the heater is to be taken out of service for an extended period of time (one year or more), the following instructions must be followed.

#### **Extended Period Shut-Down**

1. Set ON/OFF switch on the front panel to the OFF position to shut down the heater's operating controls.
2. Disconnect AC power from the unit.
3. Close the water inlet and outlet valves to isolate unit.
4. Close external gas supply valve.
5. Open relief valve to vent water pressure.

## **6.12 PLACING THE HEATER BACK IN SERVICE AFTER A PROLONGED SHUTDOWN**

After a prolonged shutdown (one year or more), the following procedures must be followed:

### **Placing Heater Back In Service After Prolonged Shutdown**

1. Review installation requirements included in Chapter 2.
2. Inspect all piping and connections to the unit.
3. Inspect exhaust vent, air duct (if applicable).
4. Perform initial startup per Chapter 4.
5. Perform safety device testing and scheduled maintenance procedures per Chapters 5 and 6 of this manual.

## CHAPTER 7 TROUBLESHOOTING GUIDE

### 7.1 INTRODUCTION

This troubleshooting guide is intended to aid service/maintenance personnel in isolating the cause of a fault in a Innovation Water Heater. The troubleshooting procedures contained herein are presented in tabular form on the following pages. These tables are comprised of three columns labeled: Fault Indication, Probable Cause and Corrective Action. The numbered items in the Probable Cause and Corrective Action columns correspond to each other. For example, Probable Cause No. 1 corresponds to Corrective Action No. 1, etc.

#### NOTE:

The front panel of the C-More Control Box contains an RS232 port which can be interfaced to a laptop computer or other suitable device. This RS232 communication feature permits service personnel to view menu items and data logs which can be useful in isolating faults. Refer to Chapter 7 of this manual for detailed RS232 communication set-up and procedures.

When a fault occurs in the unit, proceed as follows to isolate and correct the fault:

#### General Troubleshooting Instructions

1. Observe the fault messages displayed in the Control Box display.
2. Refer to the Fault Indication column in Troubleshooting Table 7-1 which follows and locate the Fault that best describes the existing conditions.
3. Proceed to the Probable Cause column and start with the first item (1) listed for the Fault Indication.
4. Perform the checks and procedures listed in the Corrective Action column for the first Probable Cause candidate.
5. Continue checking each additional Probable Cause for the existing fault until the fault is corrected.
6. Paragraph 7.2 and Table 7-2 contain additional troubleshooting information which may apply when no fault message is displayed.

If the fault cannot be corrected using the information provided in the Troubleshooting Tables, contact your local AERCO Representative.

This Page Is Intentionally Blank



**TABLE 7-1. WATER HEATER TROUBLESHOOTING**

FAULT INDICATION	PROBABLE CAUSES	CORRECTIVE ACTION
AIRFLOW FAULT DURING IGNITION	<ol style="list-style-type: none"> <li>1. Blower stopped running due to thermal or current overload</li> <li>2. Blocked Blower inlet or inlet ductwork</li> <li>3. Blocked Blower proof switch</li> <li>4. Blocked blocked-air inlet switch</li> <li>5. Defective Blower proof switch</li> <li>6. Defective blocked-air inlet switch</li> <li>7. Loose temperature to AUX connection in I/O Box</li> <li>8. Defective temperature sensor</li> <li>9. Loose wire connection between the 0-10V signal from I/O box to the Blower Motor input</li> <li>10. Defective I/O box</li> <li>11. Wrong 0-10V output selection on the control box</li> <li>12. Defective Air-Fuel Valve potentiometer</li> </ol>	<ol style="list-style-type: none"> <li>1. Check combustion blower for signs of excessive heat or high current drain that may trip thermal or current overload devices.</li> <li>2. Inspect the inlet to the combustion blower including any ductwork leading up to the combustion blower for signs of blockage.</li> <li>3. Remove the Blower proof switch and inspect for signs of blockage, clean or replace as necessary.</li> <li>4. Remove the blocked-air inlet switch and inspect for signs of blockage, clean or replace as necessary.</li> <li>5. Measure the Blower proof switch for continuity with the combustion blower running. If there is an erratic resistance reading or the resistance reading is greater than zero ohms, replace the switch.</li> <li>6. Measure the blocked-air inlet switch for continuity with the combustion blower running. If there is an erratic resistance reading or the resistance reading is greater than zero ohms, replace the switch.</li> <li>7. Check the actual inlet air temperature and measure voltage at AUX input in the I/O Box. Verify that the voltage conforms to the values shown in the tabular listing provided in Appendix C.</li> <li>8. Refer to CORRECTIVE ACTION 7 and verify that the voltage conforms to the values shown in Appendix C.</li> <li>9. Check wire connection from I/O Box 0-10V signal to the Blower Motor.</li> <li>10. Measure voltage at the I/O box 0-10V output. A voltage of 8.2V equates to a 100% open valve position.</li> <li>11. Check the <i>Analog Out</i> option on the C-More Configuration Menu. <i>Valve Position 0-10V</i> should be selected.</li> <li>12. Check Air/Fuel Valve position at 0%, 50% and 100% open positions. The positions on the VALVE POSITION bargraph should match the dial readings on the Air/Fuel Valve dial.</li> </ol>

**TABLE 7-1. WATER HEATER TROUBLESHOOTING – Continued**

FAULT INDICATION	PROBABLE CAUSES	CORRECTIVE ACTION
<p>AIRFLOW FAULT DURING PURGE</p>	<ol style="list-style-type: none"> <li>1. Blower not running or running too slow</li> <li>2. Defective Air Flow Switch</li> <li>3. Blocked Air flow Switch</li> <li>4. Blocked Blower inlet or inlet ductwork.</li> <li>5. No voltage to switch from control box.</li> <li>6. PROBABLE CAUSES from 3 to 12 for AIRFLOW FAULT DURING IGNITION applies for this fault</li> </ol>	<ol style="list-style-type: none"> <li>1. Start the unit. If the blower does not run check the blower solid state relay for input and output voltage. If the relay is okay, check the blower.</li> <li>2. Start the unit. If the blower runs, check the airflow switch for continuity. Replace the switch if there is no continuity.</li> <li>3. Remove the air flow switch and inspect for signs of blockage, clean or replace as necessary.</li> <li>4. Inspect the inlet to the combustion blower including any ductwork leading up to the combustion blower for signs of blockage.</li> <li>5. Measure for 24 VAC during start sequence from each side of the switch to ground. If 24VAC is not present refer to qualified service personnel.</li> <li>6. See CORRECTIVE ACTIONS from 3 to 12 for AIRFLOW FAULT DURING IGNITION.</li> </ol>
<p>AIRFLOW FAULT DURING RUN</p>	<ol style="list-style-type: none"> <li>1. Blower stopped running due to thermal or current overload</li> <li>2. Blocked Blower inlet or inlet ductwork</li> <li>3. Blocked airflow switch</li> <li>4. Defective airflow switch</li> <li>5. Combustion oscillations</li> <li>6. PROBABLE CAUSES from 3 to 16 for AIRFLOW FAULT DURING IGNITION applies for this fault</li> </ol>	<ol style="list-style-type: none"> <li>1. Check combustion blower for signs of excessive heat or high current draw that may trip thermal or current overload devices.</li> <li>2. Inspect the inlet to the combustion blower including any ductwork leading up to the combustion blower for signs of blockage.</li> <li>3. Remove the airflow switch and inspect for signs of blockage, clean or replace as necessary.</li> <li>4. Measure the airflow switch for continuity with the combustion blower running. If there is an erratic resistance reading or the resistance reading is greater than zero ohms, replace the switch.</li> <li>5. Run unit to full fire. If the unit rumbles or runs rough, perform combustion calibration.</li> <li>6. See CORRECTIVE ACTIONS from 3 to 16 for AIRFLOW FAULT DURING IGNITION.</li> </ol>

**TABLE 7-1. WATER HEATER TROUBLESHOOTING – Continued**

FAULT INDICATION	PROBABLE CAUSES	CORRECTIVE ACTION
<p>DELAYED INTERLOCK OPEN</p>	<ol style="list-style-type: none"> <li>1. Delayed Interlock Jumper not installed or removed.</li> <li>2. Device proving switch hooked to interlocks is not closed</li> </ol>	<ol style="list-style-type: none"> <li>1. Check for a jumper properly installed across the delayed interlock terminals in the I/O box.</li> <li>2. If there are 2 external wires on these terminals, check to see if an end switch for a device such as a pump, louver, etc. is tied these interlocks. Ensure that the device and or its end switch are functional. (jumper may be temporarily installed to test interlock)</li> </ol>
<p>FLAME LOSS DURING IGN</p>	<ol style="list-style-type: none"> <li>1. Burner Ground Screw not installed or loose.</li> <li>2. Worn flame detector</li> <li>3. No spark from Spark Plug</li> <li>4. Defective Ignition Transformer</li> <li>5. Defective Ignition/Stepper (IGST) Board</li> <li>6. Defective SSOV</li> <li>7. Carbon or other debris on Burner.</li> <li>8. Staged ignition ball valve closed.</li> <li>9. Staged ignition solenoid valve doesn't open.</li> <li>10. Clogged staged ignition piece.</li> </ol>	<ol style="list-style-type: none"> <li>1. Inspect and install/retighten Burner Ground Screw.</li> <li>2. Remove and inspect the flame detector for signs of wear. Replace if necessary.</li> <li>3. Close the internal gas valve in the unit. Install and arc a spark ignitor outside the unit.</li> <li>4. If there is no spark, check for 120VAC at the primary side to the ignition transformer during the ignition cycle.</li> <li>5. If 120VAC is not present, the IGST Board in the Control Box may be defective. Refer fault to qualified service personnel.</li> <li>6. While externally arcing the spark ignitor, observe the open/close indicator in the Safety Shut-Off Valve to ensure it is opening. If the valve does not open, check for 120VAC at the valves input terminals. If 120VAC is not present, the IGST board in the Control Box may be defective. Refer fault to qualified service personnel.</li> <li>7. Remove the burner and inspect for any carbon or debris. Clean and reinstall.</li> <li>8. Open ball valve downstream of SSOV (see Figure 7-1).</li> <li>9. When unit goes to ignition, listen to the solenoid valve for a clicking sound to ensure it is opening.</li> <li>10. Remove and inspect staged ignition piece for blockage.</li> <li>11.</li> </ol>

**TABLE 7-1. WATER HEATER TROUBLESHOOTING – Continued**

FAULT INDICATION	PROBABLE CAUSES	CORRECTIVE ACTION
FLAME LOSS DURING RUN	<ol style="list-style-type: none"> <li>1. Worn Flame Detector or cracked ceramic.</li> <li>2. Defective Regulator.</li> <li>3. Poor combustion calibration.</li> <li>4. Debris on burner.</li> <li>5. Blocked condensate drain.</li> </ol>	<ol style="list-style-type: none"> <li>1. Remove and inspect the Flame Detector for signs of wear or cracked ceramic. Replace if necessary.</li> <li>2. Check gas pressure readings using a gauge or manometer into and out of the Air/Fuel Valve to ensure that the gas pressure into and out of the valve is correct.</li> <li>3. Check combustion calibration. Adjust as necessary.</li> <li>4. Remove the burner and inspect for any carbon or debris. Clean and reinstall.</li> <li>5. Remove blockage in condensate drain.</li> </ol>
HEAT DEMAND FAILURE	<ol style="list-style-type: none"> <li>1. The Heat Demand Relays on the Ignition/Stepper board failed to activate when commanded.</li> <li>2. Relay is activated when not in Demand</li> </ol>	<ol style="list-style-type: none"> <li>1. Press CLEAR button and restart the unit. If the fault persists, replace Ignition/Stepper (IGST) Board.</li> <li>2. Defective relay. Replace IGST Board.</li> </ol>
HIGH EXHAUST TEMPERATURE	<ol style="list-style-type: none"> <li>1. Poor combustion calibration</li> <li>2. Heat exchanger has scale.</li> </ol>	<ol style="list-style-type: none"> <li>1. Check combustion calibration using procedures in Chapter 4.</li> <li>2. Clean heat exchanger using procedures in Chapter 6.</li> </ol>
HIGH GAS PRESSURE	<ol style="list-style-type: none"> <li>1. Incorrect supply gas pressure.</li> <li>2. Defective SSOV Actuator.</li> <li>3. Defective High Gas Pressure Switch</li> </ol>	<ol style="list-style-type: none"> <li>1. Check to ensure gas pressure at inlet of SSOV is 2 psig maximum.</li> <li>2. If gas supply pressure downstream of SSOV Actuator cannot be lowered, to below 3.0" W.C. using the gas pressure adjustment screw (see para. 4.3, step 10), the SSOV Actuator may be defective.</li> <li>3. Remove the leads from the high gas pressure switch and measure continuity across the common and normally closed terminals with the unit not firing. Replace the switch if it does not show continuity.</li> </ol>

**TABLE 7-1. WATER HEATER TROUBLESHOOTING – Continued**

FAULT INDICATION	PROBABLE CAUSES	CORRECTIVE ACTION
HIGH WATER TEMP SWITCH OPEN	1. Faulty Water temperature switch. 2. Incorrect PID settings. 3. Faulty shell temperature sensor. 4. Unit in Manual mode 5. Unit setpoint is greater than Over Temperature Switch setpoint. 6. System flow rate changes are occurring faster than units can respond.	1. Test the temperature switch to insure it trips at its actual water temperature setting. 2. Check PID settings against Menu Default settings in the Appendix. If the settings have been changed, record the current readings then reset them to the default values. 3. Using the resistance charts in the Appendix C, Measure the resistance of Shell sensor and BTU sensor at a known water temperature. 4. If unit is in Manual Mode switch to Auto Mode. 5. Check setpoint of unit and setpoint of Temperature Switch; Ensure that the temperature switch is set higher than the unit's setpoint. 6. If the system is a variable flow system, monitor system flow changes to ensure that the rate of flow change is not faster than what the units can respond to.
HIGH WATER TEMPERATURE	1. See HIGH WATER TEMPERATURE SWITCH OPEN. 2. Temp HI Limit setting is too low.	1. See HIGH WATER TEMPERATURE SWITCH OPEN. 2. Check Temp HI Limit setting.
IGN BOARD COMM FAULT	1. Communication fault has occurred between the PMC board and Ignition/Stepper (IGST) board	1. Press CLEAR button and restart unit. If fault persists, contact qualified Service Personnel.
IGN SWTCH CLOSED DURING PURGE	1. Air/Fuel Valve not rotating 2. Defective or shorted switch	1. Start the unit. The Air/Fuel Valve should rotate to the purge (open) position. If the valve does not rotate at all or does not rotate fully open, check the Air/Fuel Valve calibration. If calibration is okay, the problem may be in the Air-Fuel Valve or the Control Box. Refer to qualified service personnel 2. .If the Air/Fuel Valve does rotate to purge, check the ignition switch for continuity between the N.O. and COM terminals. If the switch shows continuity when not in contact with the cam replace the switch.

**TABLE 7-1. WATER HEATER TROUBLESHOOTING – Continued**

FAULT INDICATION	PROBABLE CAUSES	CORRECTIVE ACTION
(continued)	<ol style="list-style-type: none"> <li>3. Switch wired incorrectly</li> <li>4. Defective Power Supply Board or fuse</li> <li>5. Defective IGST Board</li> </ol>	<ol style="list-style-type: none"> <li>3. Check to ensure that the switch is wired correctly (correct wire numbers on the normally open terminals). If the switch is wired correctly, replace the switch</li> <li>4. Check DS1 &amp; DS2 LEDs on Power Supply Board. If they are not steady ON, replace Power Supply Board.</li> <li>5. Check “Heartbeat” LED DS1 and verify it is blinking ON &amp; OFF every second. If not, replace IGST Board</li> </ol>
IGN SWTCH OPEN DURING IGNITION	<ol style="list-style-type: none"> <li>1. Air/Fuel Valve not rotating to ignition position.</li> <li>2. Defective ignition switch</li> <li>3. Defective Power Supply Board or fuse</li> <li>4. Defective IGST Board</li> </ol>	<ol style="list-style-type: none"> <li>1. Start the unit. The Air/Fuel Valve should rotate to the purge (open) position, then back to ignition position (towards closed) during the ignition cycle. If the valve does not rotate back to the ignition position, check the Air/Fuel Valve calibration. If calibration is okay, the problem may be in the Air/Fuel Valve or the Control Box. Refer fault to qualified service personnel.</li> <li>2. If the Air/Fuel Valve does rotate to the ignition position, check the ignition position switch for continuity between the N.O. and COM terminals when in contact with the cam.</li> <li>3. Check DS1 &amp; DS2 LEDs on Power Supply Board. If they are not steady ON, replace Power Supply Board.</li> <li>4. Check “Heartbeat” LED DS1 and verify it is blinking ON &amp; OFF every second. If not, replace IGST Board.</li> </ol>
INTERLOCK OPEN	<ol style="list-style-type: none"> <li>1. Interlock jumper not installed or removed</li> <li>2. Energy Management System does not have unit enabled.</li> <li>3. Device proving switch hooked to interlocks is not closed.</li> </ol>	<ol style="list-style-type: none"> <li>1. Check for a jumper properly installed across the interlock terminals in the I/O box.</li> <li>2. If there are two external wires on these terminals check any Energy Management system to see if they have the units disabled (a jumper may be temporarily installed to see if the interlock circuit is functioning).</li> <li>3. Check that proving switch for any device hooked to the interlock circuit is closing and that the device is operational.</li> </ol>

**TABLE 7-1. WATER HEATER TROUBLESHOOTING – Continued**

FAULT INDICATION	PROBABLE CAUSES	CORRECTIVE ACTION
LINE VOLTAGE OUT OF PHASE	1. Line and Neutral switched in AC Power Box. 2. Incorrect power supply transformer wiring.	1. Check hot and neutral in AC Power Box to ensure they are not reversed 2. Check transformer wiring, in AC Power Box, against the power box transformer wiring diagram to ensure it is wired correctly
LOW GAS PRESSURE	1. Incorrect supply gas pressure. 2. Defective Low Pressure Gas Switch	1. Measure gas pressure upstream of the SSOV Actuator(s) with the unit firing. For FM gas trains, ensure it is between 4.0" W.C. and 14" W.C.. For DBB gas trains, ensure it is between 4.0" W.C. and 14" W.C. (see para. 2.7.1). 2. Measure gas pressure at the low gas pressure switch. If it is greater than 2.6" W.C., measure continuity across the switch and replace if necessary.
LOW WATER LEVEL	1. Insufficient water level in system 2. Defective water level circuitry. 3. Defective water level probe.	1. Check system for sufficient water level. 2. Test water level circuitry using the Control Box front panel LOW WATER TEST and RESET buttons. Replace water level circuitry if it does not respond. 3. Check continuity of probe end to the shell, change probe if there is no continuity.
MODBUS COMM FAULT	Unit not seeing information from Modbus network	Check network connections. If fault persists, contact qualified Service Personnel.
PRG SWTCH CLOSED DURING IGNITION	1. A/F Valve rotated open to purge and did not rotate to ignition position. 2. Defective or shorted switch.	1. Start the unit. The Air/Fuel Valve should rotate to the purge (open) position, then back to ignition position (towards closed) during the ignition cycle. If the valve does not rotate back to the ignition position, check the Air/Fuel Valve calibration. If calibration is okay, the problem may be in the Air/Fuel Valve or the Control Box. Refer fault to qualified service personnel. 2. If the Air/Fuel Valve does rotate to the ignition position, check the purge switch for continuity between the N.O. and COM terminals. If the switch shows continuity when not in contact with the cam, check to ensure that the switch is wired correctly (correct wire numbers on the normally open terminals)

**TABLE 7-1. WATER HEATER TROUBLESHOOTING – Continued**

FAULT INDICATION	PROBABLE CAUSES	CORRECTIVE ACTION
(continued)	<ol style="list-style-type: none"> <li>3. Switch wired incorrectly.</li> <li>4. Defective Power Supply Board or fuse</li> <li>5. Defective IGST Board</li> </ol>	<ol style="list-style-type: none"> <li>3. If the switch is wired correctly, replace the switch.</li> <li>4. Check DS1 &amp; DS2 LEDs on Power Supply Board. If they are not steady ON, replace Power Supply Board.</li> <li>5. Check “Heartbeat” LED DS1 and verify it is blinking ON &amp; OFF every second. If not, replace IGST Board.</li> </ol>
PRG SWTCH OPEN DURING PURGE	<ol style="list-style-type: none"> <li>1. Defective purge switch.</li> <li>2. No voltage present at switch.</li> <li>3. Switch wired incorrectly.</li> <li>4. Defective Power Supply Board or fuse</li> <li>5. Defective IGST Board</li> </ol>	<ol style="list-style-type: none"> <li>1. If the air-fuel valve does rotate, check purge switch for continuity when closing. Replace switch if continuity does not exist.</li> <li>2. Measure for 24 VAC from each side of the switch to ground. If 24VAC is not present, refer fault to qualified service personnel.</li> <li>3. Check to ensure that the switch is wired correctly (correct wire numbers on the normally open terminals).</li> <li>4. Check DS1 &amp; DS2 LEDs on Power Supply Board. If they are not steady ON, replace Power Supply Board.</li> <li>5. Check “Heartbeat” LED DS1 and verify it is blinking ON &amp; OFF every second. If not, replace IGST Board.</li> </ol>
OUTDOOR TEMP SENSOR FAULT	<ol style="list-style-type: none"> <li>1. Loose or broken wiring.</li> <li>2. Defective Sensor.</li> <li>3. Incorrect Sensor.</li> </ol>	<ol style="list-style-type: none"> <li>1. Inspect Outdoor Temperature sensor for loose or broken wiring.</li> <li>2. Check resistance of sensor to ensure it is within specification.</li> <li>3. Ensure that the correct sensor is installed.</li> </ol>
RECIRC PUMP FAILURE	<ol style="list-style-type: none"> <li>1. Internal recirculation pump failed.</li> </ol>	<p>Replace recirculation pump.</p>
REMOTE SETPT SIGNAL FAULT	<ol style="list-style-type: none"> <li>1. Remote setpoint signal not present: Not yet installed. Wrong polarity. Signal defective at source. Broken or loose wiring.</li> <li>2. Signal is not isolated (floating) if 4 to 20 mA.</li> <li>3. Control Box signal type selection switches not set for correct signal type (voltage or current).</li> </ol>	<ol style="list-style-type: none"> <li>1. Check I/O Box to ensure signal is hooked up. Hook up if not installed. If installed, check polarity. Measure signal level. Check continuity of wiring between source and unit.</li> <li>2. Check signal at source to ensure it is isolated.</li> <li>3. Check DIP switch on PMC board to ensure it is set correctly for the type of signal being sent. Check control signal type set in Configuration Menu.</li> </ol>



**TABLE 7-1. WATER HEATER TROUBLESHOOTING – Continued**

FAULT INDICATION	PROBABLE CAUSES	CORRECTIVE ACTION
RESIDUAL FLAME	1. SSOV not fully closed.  2. Defective Flame Detector	1. Check open/close indicator window of Safety Shut-Off Valve (SSOV) and ensure that the SSOV is fully closed. If not fully closed, replace the valve and or actuator. Close the 1" Gas Shut-Off Valve downstream of SSOV (Figure 7-1). Install a manometer or gauge at the leak detection port between the SSOV and Gas Shut Off Valve. If a gas pressure reading is observed replace the SSOV Valve and/or Actuator. 2. Replace Flame Detector.
SSOV FAULT DURING PURGE	See SSOV SWITCH OPEN	
SSOV FAULT DURING RUN	SSOV switch closed for 15 seconds during run.	Replace or adjust microswitch in SSOV actuator. If fault persists, replace actuator.
SSOV RELAY FAILURE	1. SSOV relay failed on IGST board.  2. Floating Neutral.  3. Hot and Neutral reversed at SSOV.	1. Press CLEAR button and restart unit. If fault persists, replace Ignition/Stepper (IGST) Board. 2. The Neutral and Earth Ground are not connected at the source and therefore there is a voltage measured between the two. This measurement should be near zero or no more than a few millivolts. 3. Check SSOV power wiring.
SSOV SWITCH OPEN	1. Actuator not allowing for full closure of gas valve  2. SSOV powered when it should not be  3. Defective Switch or Actuator  4. Incorrectly wired switch.	1. Observe operation of the Safety Shut-Off Valve (SSOV) through indicator on the Valve actuator and ensure that the valve is fully and not partially closing. 2. If the SSOV never closes, it may be powered continuously. Close the gas supply and remove power from the unit. Refer fault to qualified service personnel. 3. Remove the electrical cover from the SSOV and check switch continuity. If the switch does not show continuity with the gas valve closed, either adjust or replace the switch or actuator. 4. Ensure that the SSOV Proof of Closure switch is correctly wired.

**TABLE 7-1. WATER HEATER TROUBLESHOOTING – Continued**

<p>STEPPER MOTOR FAILURE</p>	<ol style="list-style-type: none"> <li>1. Air/Fuel Valve out of calibration.</li> <li>2. Air/Fuel Valve unplugged.</li> <li>3. Loose wiring connection to the stepper motor.</li> <li>4. Defective Air/Fuel Valve stepper motor.</li> <li>5. Defective Power Supply Board or fuse</li> <li>6. Defective IGST Board</li> </ol>	<ol style="list-style-type: none"> <li>1. Perform Stepper Test per GF-112 (para. 6.3.5) to ensure stepper motor rotates properly from 0% (fully closed) to 100% (fully open) positions. Verify VALVE POSITION bargraph and dial on the Air/Fuel Valve track each other to indicate proper operation. If operation is not correct, perform the Stepper Feedback Calibration (GF-112, para. 6.2.1).</li> <li>2. Check that the Air/Fuel Valve is connected to the Control Box.</li> <li>3. .Inspect for loose connections between the Air/Fuel Valve motor and the wiring harness.</li> <li>4. Replace stepper motor.</li> <li>5. Check DS1 &amp; DS2 LEDs on Power Supply Board. If they are not steady ON, replace Power Supply Board.</li> <li>6. Check “Heartbeat” LED DS1 and verify it is blinking ON &amp; OFF every second. If not, replace IGST Board.</li> </ol>
<p>WARNING EXHAUST TEMP HIGH (Flashing WARNING)</p>	<ol style="list-style-type: none"> <li>1. Poor combustion calibration</li> <li>2. Heat exchanger has scale.</li> </ol>	<ol style="list-style-type: none"> <li>1. Check combustion calibration using procedures in Chapter 4.</li> <li>2. Clean heat exchanger using procedures in Chapter 6.</li> </ol>

**7.2 ADDITIONAL FAULTS WITHOUT SPECIFIC FAULT MESSAGES**

Refer to Table 7-2 to troubleshoot faults which may occur without a specific fault message being displayed.

**TABLE 7-2. WATER HEATER TROUBLESHOOTING WITH NO FAULT MESSAGE DISPLAYED**

OBSERVED INCIDENT	PROBABLE CAUSES	CORRECTIVE ACTION
Hard Light-Off	1. Staged Ignition Ball Valve closed. 2. Clogged/damaged Gas Injector on Igniter-Injector (Figure 7-2). 3. Defective Staged Ignition Solenoid (Figure 7-2)	1. Open the 1/4" Staged Ignition Ball Valve on the downstream side of the SSOV (Figure 7-1). 2. Disconnect the Staged Ignition Assembly from the Igniter-Injector and inspect Gas Injector to ensure it is not clogged or damaged. 3. Close the 1" Manual Shutoff Valve and the 1/4" Ball Valve that connects to the flex hose of the Staged Ignition Assy. (Figure 7-1). Attempt to start the unit and listen for a "clicking" sound that the Staged Ignition Solenoid makes during Ignition Trial. If "clicking" sound is not heard after 2 or 3 attempts, replace the Staged Ignition Solenoid.
Fluctuating Gas Pressure	1. Gas pressure going into unit is fluctuating. 2. Damping Orifice not installed.	1. Stabilize gas pressure going into unit. If necessary, troubleshoot Building Supply Regulator. 2. Check to ensure that the Damping Orifice is installed in the SSOV Actuator shown in Figure 7-3. (For DBB Gas Trains, the Damping Orifice is installed in the downstream SSOV Actuator).
Air/Fuel Valve "hunting" at the 80% Valve Position	1. IGST and Power Supply Boards in Control Box are outdated.	1. Check to ensure that the IGST and Power Supply Boards are Rev. E or higher.

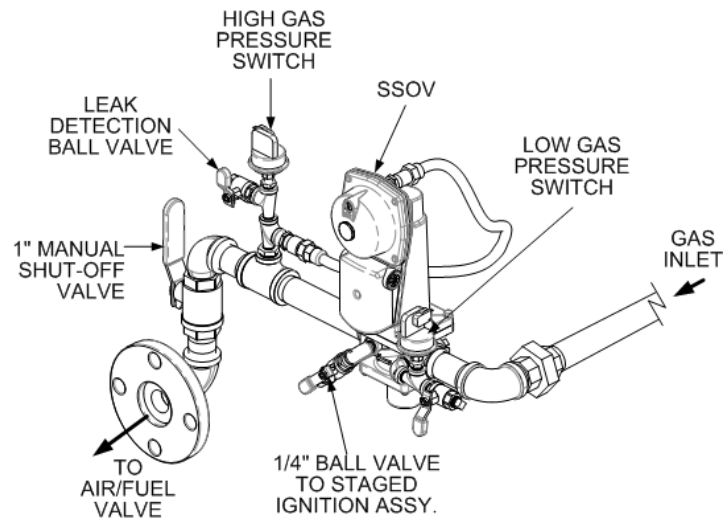

Figure 7-1. Gas Train Component Locations

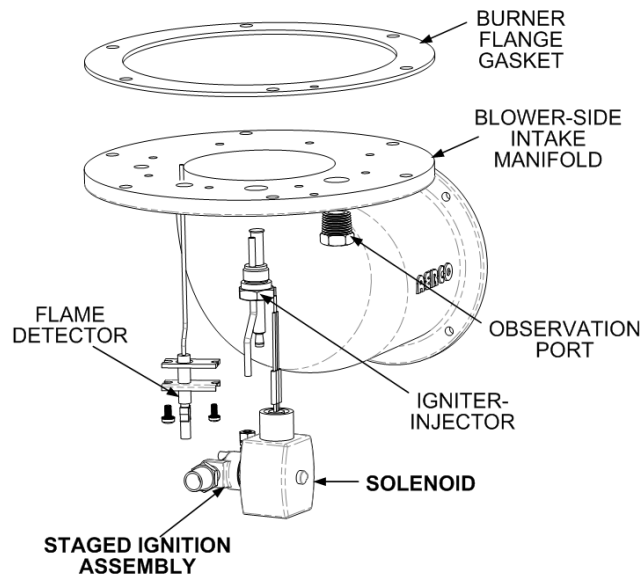
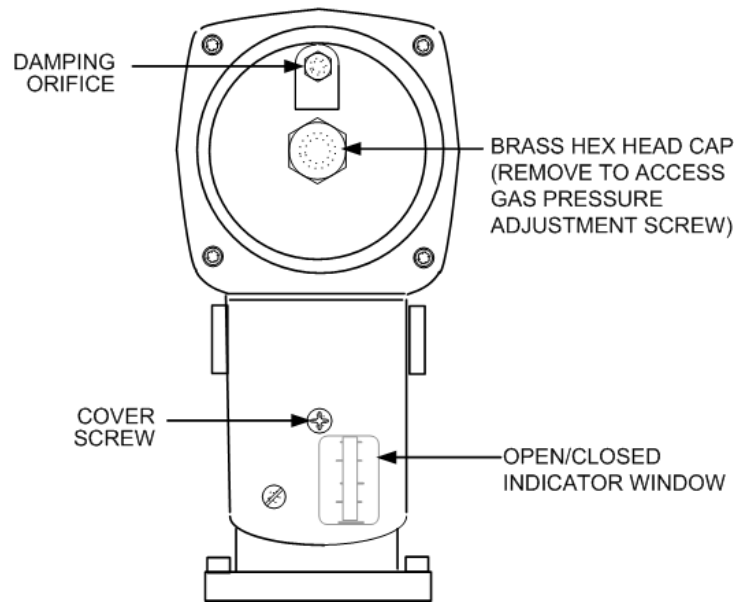

Figure 7-2. Blower-Side Intake Manifold (Shown removed from Heater)



**Figure 7-3. SSOV Actuator With Gas Pressure Adjustment & Damping Orifice**

This Page Is Intentionally Blank

## CHAPTER 8 RS232 COMMUNICATION

### 8.1 INTRODUCTION

The RS232 port on the front panel of the C-More Control Box (Figure 3-1) can be interfaced to a laptop computer or other suitable terminal using a RS232 adapter cable. RS232 communication can be accomplished using any “Dumb Terminal” emulation, such as “Hyper Terminal” which is included with Microsoft Windows. The RS232 communication feature permits viewing or changing of Control Panel menu options and also provides access to data logs showing Event Time Line, Fault and Sensor log displays.

### 8.2 RS232 COMMUNICATION SETUP

Regardless of the terminal emulation utilized, the following guidelines must be adhered to when setting up the RS232 communication link:

- Baud Rate – The baud rates which can be used with the C-More Control Panel are:
  - 2400
  - 4800
  - 9600 (Default)
  - 19.2K
- Data Format – The program must be set for: 8 data bits, 1 stop bit, no parity and either Xon/Xoff or No flow control.

### 8.3 MENU PROCESSING UTILIZING RS232 COMMUNICATION

Viewing data logs and viewing or changing Control Panel menu options using RS232 communication is accomplished as follows:

#### RS232 Menu Processing

1. Start the emulator software program and ensure that the specified baud rate and data formats have been entered.
2. Press the Enter key on the laptop. An asterisk (\*) prompt should appear.
3. At the prompt, enter the valid RS232 password (jaguar) in lower case letters and press Enter.
4. “Welcome to Aerco” will appear in the laptop or “dumb terminal” display with a listing of the following available entry choices:

M = Display next Menu  
D = Display menu items  
N = Display next menu items  
Cxx = Change item xx  
F = Fault log display  
S = Sensor log display  
T = Time line display  
L = Log off

### RS232 Menu Processing - Continued

#### NOTE

The Level 1 password (159) must be entered to change options in the Setup, Configuration and Tuning Menus. The Level 2 password (6817) must be entered to view or change options in the Calibration and Diagnostics Menus.

With the exception of the password entry, all other keyboard entries can be made using either upper or lower case.

5. To view the available menus in the top-down sequence shown in Figure 3-2, enter *M* <*Rtn*>. The Menu title and first 10 options will be displayed.
6. When viewing menus containing more than 10 options, enter *N* <*Rtn*> to display the remaining options.
7. Shortcut keys are also available to go directly to a specific menu. These shortcut keys are:

m0	Default (Operating) Menu
m1	Setup Menu
m2	Configuration Menu
m3	Tuning Menu
m4	Calibration Menu
m5	Diagnostic Menu

8. To change a value or setting for a displayed menu option, proceed as follows:
  - (a) Enter *C*, followed by the number to the right of the displayed option to be changed, and then press <*Rtn*>.
  - (b) Enter the desired value or setting for the option and press <*Rtn*>. Refer to Chapter 3, Tables 3-2 through 3-5 for allowable entry ranges and settings for the Operating, Setup, Configuration and Tuning Menus. (The Calibration and Diagnostic Menus should only be used by Factory-Trained service personnel).
  - (c) Menu changes will be stored in non-volatile memory.
9. To redisplay the menu and view the option which was just changed in step 5, enter *D* and press <*Rtn*>.
10. To display the Fault (*F*) Log, Sensor (*S*) Log or Time (*T*) Line Log, press *F*, *S* or *T* followed by <*Rtn*>. Refer to paragraph 9.4 for descriptions and samples of these data logs.
11. To log off and terminate the RS232 communication link, press *L* followed by <*Rtn*>.

## 8.4 DATA LOGGING

During operation, the C-More Control Panel continuously monitors and logs data associated with operational events, faults and sensor readings associated with the water heater system. Descriptions of these data logs are provided in the following paragraphs. The basic procedure for accessing each data log is described in paragraph 9.3, step 7.

### 8.4.1 Fault Log

The C-More Control Panel logs the last 10 faults (0 – 9) starting with the most recent (#0). They can be viewed in the front panel display or via the RS232 port. The Fault Log cannot be cleared. If the Fault Log already contains 10 faults, the earliest fault is overwritten when a new fault occurs. A sample Fault Log display is shown in Table 8-1.



**NOTE**

The Operation Time (T) Log can store thousands of records. Therefore, to view the most recently logged record, enter "T" followed by 0 (zero) and press Enter (i.e. T0 <Enter>). To view earlier records in reverse chronological order, enter T and press Enter. To go back 200 or 1000 records, enter T200 or T1000, etc. and press Enter.

**8.4.2 Operation Time Log**

The Operation Time Log consists of a string of ASCII records stored in non-volatile memory within the C-More Control Panel. Events such as power-up, ignition and turn-off are time stamped. Data logged while the unit is running are run-length encoded. Data is logged or the run-length incremented every 30 seconds. For a new run record to be logged, the fire rate or flame strength must change by more than 5%, or the run mode must change. At steady-state, the run-length is allowed to reach a maximum of 30 minutes before the record is logged. This means that no more than 30 minutes of data can be lost if the unit loses power. Table 8-2 shows a sample Operation Time Log for a unit:

The Operation Time Log can only be accessed through the RS232 interface using a laptop or other terminal device. Ten operation time records are displayed for each T command entry. The operation time log can be cleared ONLY by factory authorized personnel using the Clear Log option in the Factory menu.

**NOTE**

The Sensor (S) Log can store up to 1200 records. Therefore, to view the most recently logged record, enter "S" followed by 0 (zero) and then press Enter (i.e. S0 <Enter>). To view earlier records in reverse chronological order, enter S and press Enter. To go back 200 or 700 records, enter S200 or S700, etc. and press Enter.

**8.4.3 Sensor Log**

The sensor values can be logged at a different rate if needed by setting the Sensor Log Interval in the Diagnostics Menu. The log interval can vary from once every minute to once every day. Table 8-3 shows a sample Sensor Log every 5 minutes for a heater running in Constant Setpoint mode.

**Table 8-1. Sample Fault Log Display**

No.	Fault Message	Cycle	Date	Time
0	Direct Drive Signal Fault	609	1/10/02	8:42am
1	Low Gas Pressure	366	7/04/01	5:29pm
2	Loss of Power	0	1/01/01	11:50am

**Table 8-2. Sample Operation Time Log Display**

Status	Fire Rate	Flame	Run Length	Date	Time
Off, Direct Drive	0	0	8	1/15/02	2:35pm
Run, Direct Drive	38	100	34	1/15/02	2:27pm
Run, Direct Drive	31	100	30	1/15/02	1:53am
Run, Direct Drive	35	100	2	1/15/02	1:23pm
Run, Direct Drive	29	100	0	1/15/02	1:21pm
Ignition	0	0	0	1/15/02	1:20pm
Off, Switch	0	0	35	1/15/02	12:30pm
Run, Manual	40	100	0	1/15/02	11:55am
Ignition	0	0	0	1/15/02	11:55am
Power-up	0	0	0	1/15/02	11:50am

**Table 8-3. Sample Sensor Log Display**

Setpt	Outlet	Outdr	FFWD	Aux	Inlet	Exhst	CO	O2	Flow	Date	Time
130	181	OPEN	OPEN	OPEN	OPEN	OPEN	0	.0	0	1/15/02	5:51pm
130	180	OPEN	OPEN	OPEN	OPEN	OPEN	0	.0	0	1/15/02	5:46pm
130	180	OPEN	OPEN	OPEN	OPEN	OPEN	0	.0	0	1/15/02	5:41pm
130	179	OPEN	OPEN	OPEN	OPEN	OPEN	0	.0	0	1/15/02	5:36pm
130	180	OPEN	OPEN	OPEN	OPEN	OPEN	0	.0	0	1/15/02	5:31pm
130	180	OPEN	OPEN	OPEN	OPEN	OPEN	0	.0	0	1/15/02	5:26pm
130	180	OPEN	OPEN	OPEN	OPEN	OPEN	0	.0	0	1/15/02	5:21pm
130	180	OPEN	OPEN	OPEN	OPEN	OPEN	0	.0	0	1/15/02	5:16pm
130	179	OPEN	OPEN	OPEN	OPEN	OPEN	0	.0	0	1/15/02	5:11pm
130	180	OPEN	OPEN	OPEN	OPEN	OPEN	0	.0	0	1/15/02	5:06pm

## CHAPTER 9 WATER HEATER MANAGEMENT

### NOTE

Some of the descriptions and procedures provided in this Chapter may duplicate information provided in previous Chapters of this manual. This is being done to minimize referencing back to these descriptions and procedures and organize all WHM related information into a single Chapter. It is assumed that the user is familiar with the basic C-More Menu processing procedures used throughout this manual.

### 9.1 INTRODUCTION

The C-More Water Heater Management (WHM) feature is designed for use with multiple AERCO Water Heaters equipped with C-More Controllers. The software code required to operate the WHM resides in each of the C-Mores that are part of the system. The WHM can control up to eight (8) water heaters in parallel. Each water heater controlled by the WHM must be equipped with an Actuator-Controlled Sequencing Valve, Part No. 92093. These valves are installed on the cold water inlet of each water heater being controlled by the WHM.

### 9.2 GENERAL DESCRIPTION

The C-More Water Heater Management System (WHM) is designed to ensure that all water heaters in the system operate at maximum efficiency. This is accomplished by monitoring the Air/Fuel Valve position (VP) of all water heaters that have their sequencing valves open. Units with open sequencing valves are called enabled units. Units with closed sequencing valves are called disabled units. Units which are unable to function, due to a fault or user intervention, are called offline units. When there is minimal or no demand for hot water, the sequencing valve for one unit will be open. As system load increases, the WHM will open the sequencing valves on additional heaters. A simplified block diagram of multiple water heaters connected to a WHM is shown in Figure 9-1.

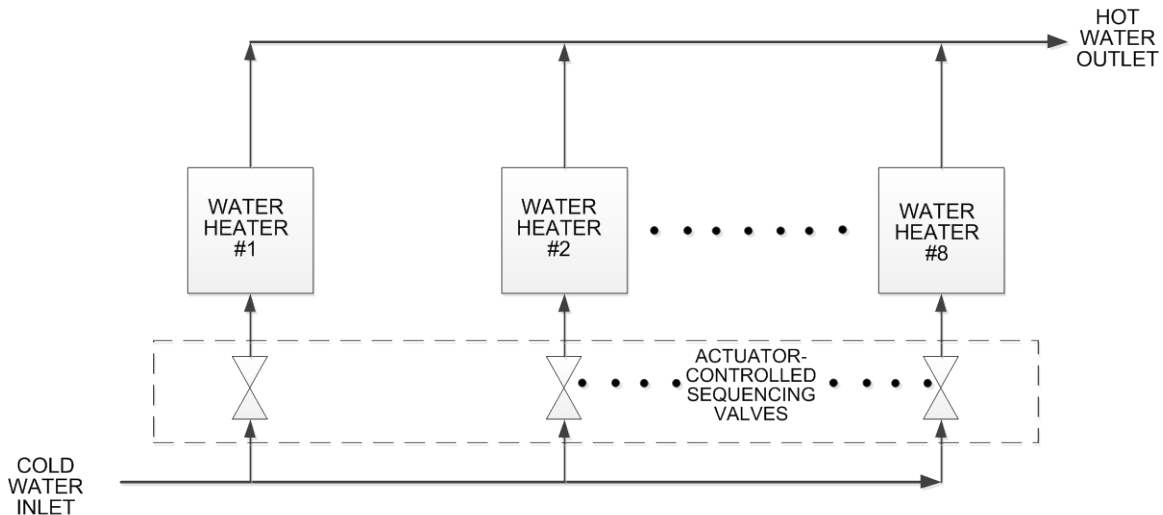

Figure 9-1. Simplified Block Diagram - Water Heater Management (WHM)

### 9.3 WHM PRINCIPLES OF OPERATION

The WHM system communicates with the plant water heaters via a RS485 network utilizing Modbus RTU protocol (8 bit, 9600 baud, no parity). All Modbus networks are implemented using a Master/Slave scenario where only one device, the Master, can initiate a communication sequence. All other C-More equipped units on the network are called Slaves. However, since the WHM software code resides in each C-More that is part of the system, any one of the C-Mores can be selected to control the system.

The controlling Master monitors the Air/Fuel Valve position (VP) of all enabled units. When this valve position (% open) exceeds a user-selectable limit (WHM Nxt On VP), the WHM will open the sequencing valve of another water heater in the system. Conversely, when the valve positions of all enabled units have dropped below a different user-selectable limit (WHM Nxt Off VP) threshold, the WHM will close the sequencing valve on a unit. The philosophy behind this approach is to maintain the fire rates (Air/Fuel Valve % open) at a level that maximizes heater efficiency.

In addition to collecting Air/Fuel Valve position data, the controlling Master also monitors the total accumulated operating time for each unit on the system and attempts to balance the system so that all units operate for approximately the same number of hours.

### 9.4 WHM MENU

The WHM Menu in each C-More can only be viewed when the *Unit Type* option in the Configuration Menu is set to *Innovation WH*. The WHM Menu contains only ten (10) user-selectable menu options. In addition These menu options are listed in Table 9-1. Descriptions for each of these menu items are included in Appendix A.

#### NOTE

In addition to the WHM Menu items listed in Table 9-1, the Setup Menu contains a *Comm Address* option which must be entered for each unit to enable WHM control of the system.

**Table 9-1. WHM Menu**

Menu Item Display	Available Choices or Limits		Default
	Minimum	Maximum	
WHM Mode	Off, WHM Slave, WHM Master		Off
WHM Setpoint	40°F	200°F	130°F
WHM Nxt On VP	16%	100%	75%
WHM Nxt Off VP	16%	100%	35%
Lead/Lag Hours	25	225	72
Setback Setpoint	40°F	220°F	130°F
Setback Start	12:00am	11:59pm	12:00am
Setback End	12:00am	11:59pm	12:00am
WHM Auto Mstr	Yes or No		No
WHM Auto Timer	10 sec.	120 sec.	30 sec.

## 9.5 WHM HARDWARE INSTALLATION & SET-UP INSTRUCTIONS

The following paragraphs provide the basic installation and set-up instructions for implementing a Water Heater Management System (WHM) to control up to eight (8) AERCO Innovation Water Heaters. Some of the descriptions and procedures included in Chapter 2 may be repeated here to avoid unnecessary referencing.

### 9.5.1 Hardware Installation

All Innovation Water Heaters which will be controlled by a WHM master must be equipped with an actuator-controlled sequencing valve (part no. 92093). If this valve is not already installed on the cold water inlet, proceed as follows:

#### WHM Hardware Installation

1. Remove the sequencing valve from its stowed location.
2. Refer to Figure 9-2 and attach the valve to the cold water inlet of the unit using the pipe union and nipple provided.
3. Ensure that the valve is positioned with the actuator enclosure position as shown in Figure 9-2.
4. AERCO recommends that another pipe nipple and union be attached to the valve inlet prior to connecting the cold water supply piping.
5. Tighten all pipe connections after the sequencing valve is properly positioned.
6. Connect the 3-pin Molex connector on the sequencing valve to the mating connector on the Innovation harness at the rear of the unit.
7. This completes the sequencing valve installation.

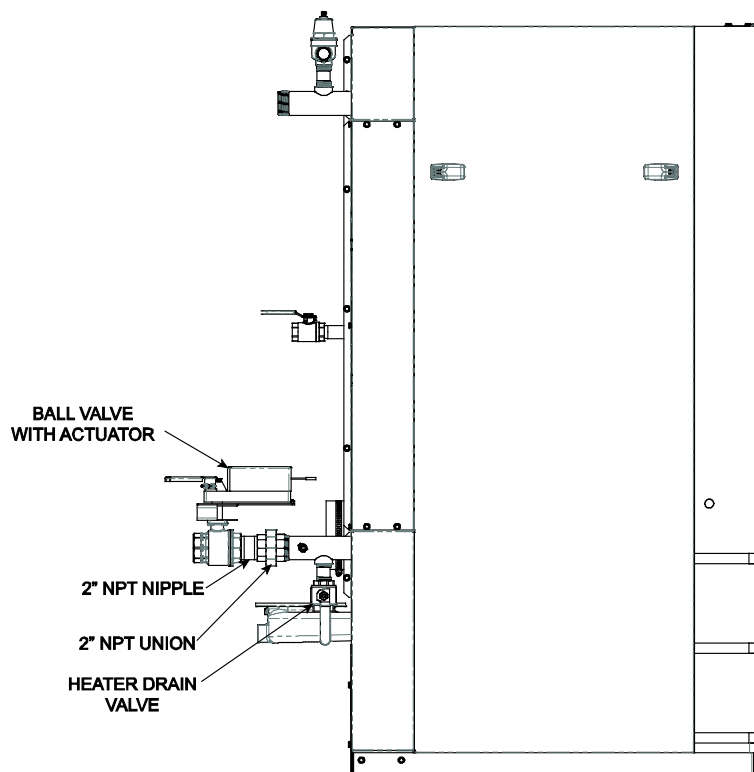

**Figure 9-2. Innovation Water Heater Equipped With Sequencing Valve**

### 9.5.2 WHM Modbus Network Wiring

As previously mentioned, all units being controlled by the WHM will be connected to a RS485 Modbus Network. All Modbus networks are wired in a daisy-chain configuration using a Master/Slave scenario as shown in Figure 9-3.

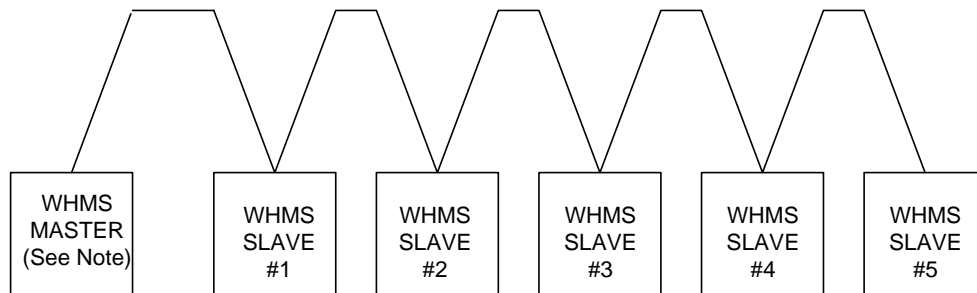

NOTE: The WHMS Master does not necessarily have to be on either end of the Daisy-Chain loop,

**Figure 9-3. Typical Daisy-Chain Modbus/RS485 Network**

Any one of the C-More WHM units included in the Modbus network can be the Master. However, it is recommended that you decide which unit will be the Master and which will be the last unit on the daisy-chain prior to performing the wiring connections. This will simplify wiring connections and Modbus address assignments,

Modbus network wiring connections must be made using shielded twisted-pair wiring, (18 – 24 AWG) such as Belden #9841, #3105A, #8760, or equivalent. The Modbus wiring connections are made at the RS485 COMM terminals on the I/O board included with each C-more Control System.

Connect the Modbus wiring as follows:

#### **Modbus Network Wiring**

1. Starting at the first unit, connect the twisted, shielded pair cable to the RS485 Comm plus (+) and minus (-) terminals on the left side I/O board as shown in Figure 9-4.
2. At the Modbus Master I/O board, activate the DIP switch labeled “MODBUS TERM” by placing it in the up position. This will connect a termination resistor across the terminals at the source end.
3. Refer to Figure 9-4 and run the shielded cable to the next unit in the daisy-chain and connect the + and – wire leads (+ to +, - to -). DO NOT terminate the shield of the RS485 Comm leads to the SHIELD terminal at the Slave. Instead, connect the shields of the incoming and outgoing RS485 leads together.
4. Continue connecting the + and - wire leads and shields for the remaining units as described in step 3 for the remaining Slave units in the chain.
5. At the end unit in the chain, activate the DIP switch labeled “MODBUS TERM” by placing it in the up position. This will ensure that the termination resistors are activated at both ends of the loop.

### 9.5.3 Control and Power Wiring

Control and power wiring connections to the sequencing valves associated with each C-More WHM unit is accomplished by simply ensuring that the 3-pin Molex connectors on the units are connected to the corresponding connectors on the valves.

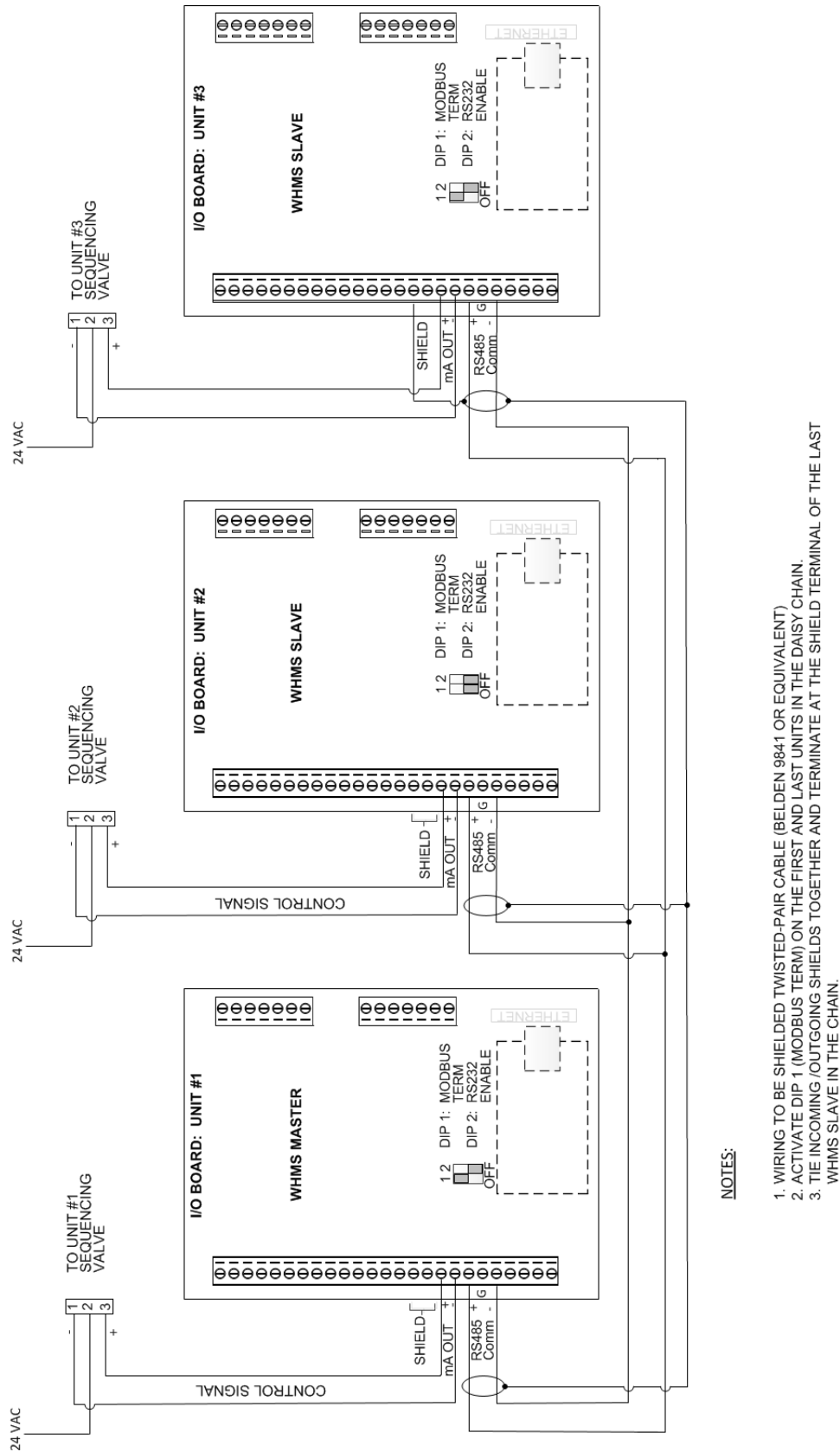

**NOTES:**

1. WIRING TO BE SHIELDED TWISTED-PAIR CABLE (BELDEN 9841 OR EQUIVALENT)
2. ACTIVATE DIP 1 (MODBUS TERM) ON THE FIRST AND LAST UNITS IN THE DAISY CHAIN.
3. TIE INCOMING /OUTGOING SHIELDS TOGETHER AND TERMINATE AT THE SHIELD TERMINAL OF THE LAST WHMS SLAVE IN THE CHAIN.

Figure 9-4. WHMS Network Wiring Diagram

## 9.6 WHM MENU SETTINGS

The required settings for WHM Menu items listed in Table 9-1 will vary depending on the number of units connected to the Modbus network and required setpoint and operating conditions to be maintained on the network. Set the menu options in accordance with the descriptions provided in the paragraphs 9.6.1 through 9.6.6 which follow.

### NOTE

It is recommended that the WHM Menu settings described in the following paragraphs be performed first at the WHM Master. This will simplify the number of required entries since most of the settings will be “pushed” to the appropriate Slaves.

#### 9.6.1 WHM Mode

Set the WHM Mode option to *WHM Master* for the controlling Master. Set the WHM Mode option to WHM Slave for all other units on the Modbus network.

#### 9.6.2 Comm Address (Located in Setup Menu)

This option, located in the Setup Menu, is the Modbus address for the for the water heater on the network. To simplify addressing, assign consecutive address numbers 1 through 8.

#### 9.6.3 WHM Setpoint

The default setpoint for the WHM is 130°F. If a different setting is desired, the setpoint can be varied from 40°F to 240°F.

#### 9.6.4 WHM Nxt On VP

This is the Next On Air/Fuel Valve Position (VP), % open) for the system. The default value for this option is 75%. When all enabled water heaters have a valve position (VP) greater than this value, the WHM Master will enable another water heater, if one is available. If a different value is desired for the system, this menu option can be varied from 16% to 100%. The selected value must always be greater than the Next Off Valve Position, and there should be a reasonable spread between the two values.

#### 9.6.5 WHM Nxt Off VP

This is the Next Off Air/Fuel Valve Position (VP), % open) for the system. The default value for this option is 35%. When all enabled water heaters have a valve position (VP) less than this value the WHM will disable one of the enabled water heaters. The exception to this rule is if there is only one water heater currently enabled.

#### 9.6.6 Lead/Lag Hours

The Lead/Lag Hours menu option is basically designed to spread the total number of run hours accumulated on all units in the system so that each of the units have approximately the same number of run hours. The default value for this option is 72 hours.

#### 9.6.7 Setback Setpoint

This menu item specifies the setpoint temperature that the WHM system will maintain during time periods of low DHW demand.

#### 9.6.8 Setback Start & Setback End

These two menu items specify the start and end times that the Setback Setpoint will be in effect. The start and end times can be set from 12:00am (mid-night) to 11:59pm. To disable the setback feature, leave the start and end times set to 12:00am (midnight).



### 9.6.9 WHM Auto Mstr

Password Level 2 (6817) must be entered in order to access the WHM Auto Mstr menu option. This item is used to enable (yes) or disable (no) an Automatic Master switch-over function. When enabled (yes), the WHM will automatically select a new Master if the current Master fails or loses power. This option is used with the WHM Auto Timer option described in the following paragraph. The default for this option is No (disabled).

### 9.6.10 WHM Auto Timer

Password Level 2 (6817) must be entered in order to access the WHM Auto Timer menu option. When the WHM Auto Mstr option is set to Yes (enabled), the WHM Auto Timer option allows the user to select the elapsed time interval between failure of the WHM Master and switch-over to a new WHM Master. The default for this option is 30 seconds.

## 9.7 WHM PROGRAMMING & START-UP

Prior to programming the required WHM Menu options into the WHM Master and Slaves, all required hardware installation and network wiring must be completed. In addition, the required menu entries to be entered must be determined based on the descriptions in the previous paragraphs.

AERCO recommends that the WHM Master be set up first. By doing so, the Master will “push” most of the required menu entries to each WHM Slave as each unit is brought on-line. The following steps assume that the WHM Master and Slaves will be consecutively numbered, starting at 1 (WHM Master). Proceed as follows starting at the unit which has previously been determined to be the WHM Master:

### WHM Programming & Start-Up Procedure

1. Access the Setup menu and scroll to the *Comm Address* option. Press the CHANGE key.
2. Enter 1 for the Comm Address of the Master. Press the ENTER key to store the entry.
3. Access the WHM menu and scroll to the *WHM Mode* option (default = Off).
4. Press the CHANGE key.
5. Select *WHM Master*. Press the ENTER key to store the entry. Note that the Outlet Temperature display on the WHM Master will begin flashing every two seconds.
6. Select the *WHM Setpoint* option. The default value is 130°F. If this is not the desired setpoint for the WHM, press the CHANGE key.
7. Enter the desired WHM setpoint temperature. Press ENTER to store the selection.
8. Scroll to the *WHM Nxt On* option (default = 75%). If the desired setting for this option is not displayed, press the CHANGE key.
9. Enter the desired value for the Nxt On option. Press ENTER to store the selection.
10. Scroll to the *WHM Nxt Off* option (default = 35%). If the desired setting for this option is not displayed, press the CHANGE key.
11. Enter the desired value for the Nxt Off option. Press ENTER to store the selection.
12. Scroll to the *Lead/Lag Hours* option (default = 72). If the desired setting for this option is not displayed, press the CHANGE key.
13. Enter the desired value for the Lead/Lag Hours option. Press ENTER to store the selection.
14. The WHM menu contains *Setback* options which are used to adjust the setpoint temperature, start time and end time during periods of low DHW demand. These options are selected as specified in steps 15 through 18 which follow.

### WHM Programming & Start-Up Procedure - Continued

15. To specify the setback temperature, scroll to the *Setback Setpoint* option (default = 130°F). If this is not the desired setting, press the CHANGE key.
16. Enter the desired *Setback Setpoint* temperature. Press ENTER to store the selection.
17. Next, the *Setback Start* and *Setback End* time options must be specified (defaults = 12:00am for both options). To change each option scroll to *Setback Start* or *Setback End* and press the CHANGE key.
18. Separately enter the desired Start and End time (12:00am to 11:59pm). Press ENTER to store each entry.
19. This completes the required entries for the WHM Master. All but two of the required menu setting will be automatically be “pushed” to the WHM Slaves as they are brought on-line. The options which are not “pushed” to each WHM Slave are:
  - Comm Address (in Setup menu)
  - WHM Mode
20. Enter the desired Comm Address and WHM Mode (WHM Slave) at the C-More Control Panel for each of the WHM Slaves on the network.
21. After the required entries are made at each WHM Slave, check to ensure the REMOTE LED on the C-More Control Panel for each unit in the WHM network is illuminated. When illuminated, it indicates that the RS485 communications are operating properly.
22. The WHM menu contains two additional menu options which can be set at the WHM Master. These options are *WHM Auto Mstr* and *WHM Auto Timer*. In order to view or change these two options, the Level 2 Password (6817) must be entered as follows:
  - (a) Press the MENU key on the front panel of the C-More and access the *Setup* Menu.
  - (b) Scroll to the *Password* menu option and press the CHANGE key.
  - (c) Enter 6817 and then press the ENTER key to store the password.
  - (d) Press the MENU key on the C-More and scroll back to the *WHM* Menu.
23. Scroll to the *WHM Auto Mstr* option. The default value for this option is Off (disabled). If you wish to enable this option, select Yes and then press the ENTER key to store the setting.
24. If the *WHM Auto Mstr* option was set to Yes (enabled) in step 23, proceed to step 25. If this option remains set to No (disabled), skip step 25 and go to step 27.
25. Scroll to the *WHM Auto Timer* option will appear. This option is used to select the elapsed time interval between failure of the WHM Master and switch-over to a new WHM Master (default = 30 seconds). If desired, this time interval can be changed to any value within the allowable range of 10 to 120 seconds. To alter this setting, press the CHANGE key and enter the desired time interval. Press the ENTER key to store the new setting.
26. The WHM Auto Mstr and WHM Auto Timer options will be automatically “pushed” to the WHM Slaves on the network.
27. This completes all programming for the WHM.

**9.8 TROUBLESHOOTING**

Faults which may occur during WHM operation include the items listed in Table 9-2.

**Table 9-2. WHM Troubleshooting**

FAULT INDICATION	PROBABLE CAUSE	CORRECTIVE ACTION
OUTLET TEMPERATURE display is flashing on 2 C- More Control Panels	1. Two C-Mores have their WHM Mode menu option set to WHM Master	1. Check the WHM Mode entries in the units which have their displays flashing. Change one of the WHM Mode settings to WHM Slave.
REMOTE LED on one or more WHM units is Off.	1. Improperly connected or faulty RS485 Modbus wiring.  2. Improper Comm address.  3. Unit Comm address is not unique.	1. Check the polarity of the RS485 Comm connections on the I/O board of the affected unit. Also, ensure that all Modbus wiring connections to the unit are secure.  2. Verify that the address of the affected unit is within the allowable range (1 thru 8).  3. Check to ensure that none of the units have the same Comm address.
Actuator-controlled sequencing valve does not open	1. Control cable not connected to valve actuator.  2. 24 VAC power not being supplied to valve actuator.  3. Defective valve actuator.	1. Ensure that the control cable from the unit's I/O Box is connected to the valve actuator.  2. Remove the enclosure cover from the valve actuator and verify that 24 VAC is present at Terminal 2 of the actuator.  3. Replace valve actuator. Following replacement, the actuator stroke will have to be calibrated to ensure it fully opening and closing.

## 9.9 SEQUENCING VALVE DESCRIPTION & OPERATION

Brief descriptions of Actuator-Controlled Sequencing Valve, part no. 92093 and its operating characteristics are provided in paragraphs 9.9.1 and 9.9.2, respectively

### 9.9.1 Sequencing Valve Description

The Actuator-Controlled Sequencing Valve shown in Figure 9-5 is comprised of the following main components:

- 2" Brass Ball Valve
- Actuator Linkage
- Actuator Housing
- Valve Shaft Handle

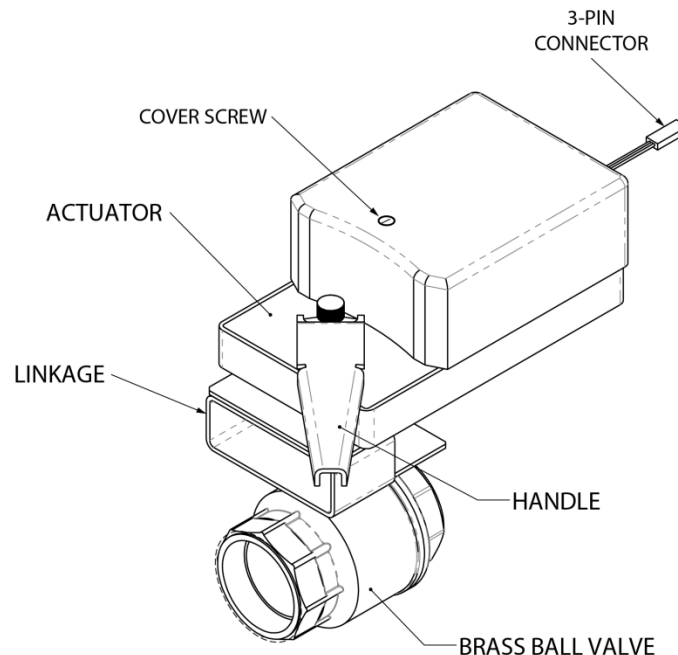

**Figure 9-5. Actuator-Controlled Sequencing Valve (92093)**

The Actuator Housing contains a cover which is removed by simply loosening a single captive screw. Removing the cover provides access to a PC Board containing wiring connections and control circuitry components as shown in Figure 9-6.

The components on the PC board include DIP switches which are preset at the factory and should not be changed unless instructed to do so.

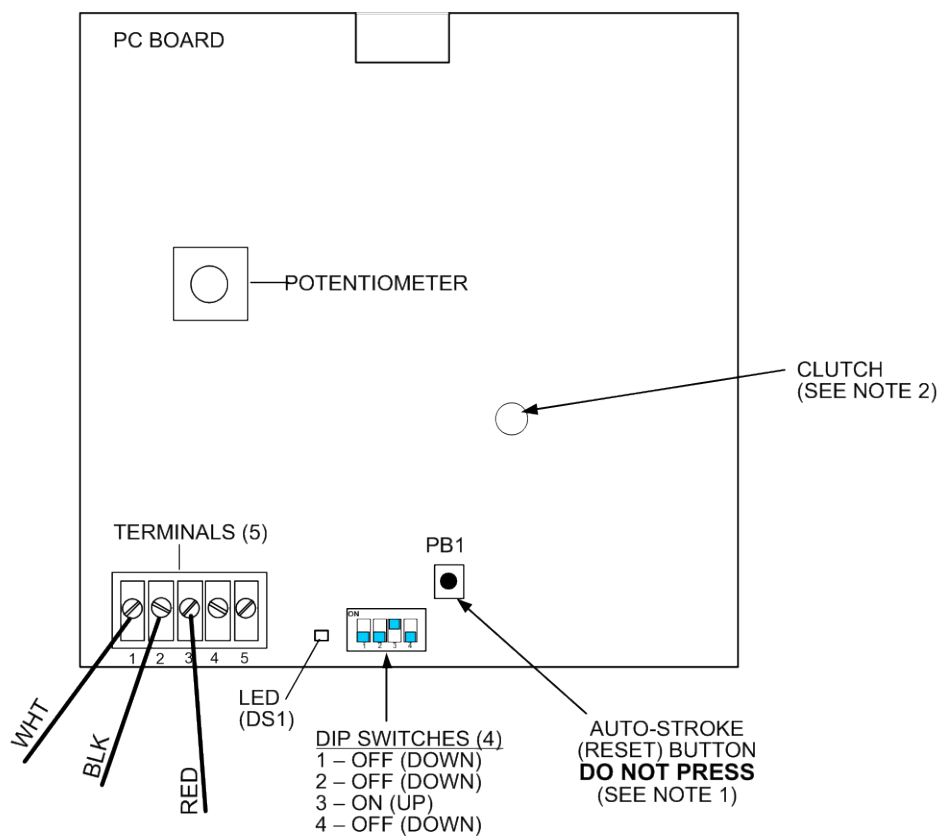

**NOTES:**

1. **DO NOT PRESS AUTO-STROKE (RESET) BUTTON.** DOING SO MAY ALTER ACTUATOR CALIBRATION.
2. DEPRESS AND HOLD BRASS CLUTCH BUTTON TO MANUALLY ROTATE VALVE.

**Figure 9-6. Actuator PC Board Components**

**⚠ CAUTION ⚠**

Power must be removed from the Actuator prior to attempting to disengage the clutch. Failure to observe this precaution may damage the Actuator.

The PC board also contains a brass button which is used to disengage the clutch and permit the ball valve to be manually rotated. To disengage the clutch, proceed as follows:

### **Actuator Clutch Disengagement**

1. Disconnect the 3-pin connector on the Actuator to ensure that 24 VAC power is not being supplied
2. Press and hold the brass Clutch button shown in Figure 9-6.
3. With the Clutch button depressed, the ball valve can be manually rotated from the fully open (90°) to the fully closed (0°) position.

### **9.9.2 Sequencing Valve Operating Characteristics**

The Sequencing Valve is powered by 24 VAC which is supplied from a step-down transformer located in the Power Box of the Innovation Water Heater. The 24 VAC power output and a 0 to 20 mA control signal from the I/O Box of the Water Heater are routed to the Sequencing Valve via a 3-pin Molex connector.

During normal Water Heater Management (WHM), a control signal of less than (<) 4 mA will rotate the valve to the fully open (0°) position. Conversely, a control signal above 14 mA will rotate the valve to the fully closed (90°) position. The valve position can be observed on the scale provided on the Actuator Linkage.

**APPENDIX A: INNOVATION MENU ITEM DESCRIPTIONS**

MENU LEVEL & OPTION	DESCRIPTION
<b><u>OPERATING MENU</u></b>	
Active Setpoint	This is the setpoint temperature to which the control is set when operating in the Constant Setpoint or Remote Setpoint Mode. When in the Constant Setpoint Mode, this value is equal to the Internal Setpoint setting in the Configuration Menu. When in the Remote Setpoint Mode, this value is the setpoint equivalent to the remote analog signal supplied to the unit
Air Temp	For monitoring purposes only
Outdoor Temp	Displayed only if outdoor sensor is installed and enabled.
Valve Position In	Desired input valve position. This would normally be the same as the valve position shown on the bargraph when the heater is operating.
Flame Strength	Displays flame strength from 0% to 100%.
Run Cycles	Displays the total number of run cycles from 0 to 999,999.
Run Hours	Displays total run time of unit in hours from 0 to 9,999,999.
Fault Log	Displays information on the last 20 faults (0 – 19).
<b><u>SETUP MENU</u></b>	
Password	Allows password to be entered. Once the valid password (159) is entered, options in the Setup, Configuration and Tuning Menus can be modified.
Language	English only
Time	Displays time from 12:00 am to 11:59 pm.
Date	Displays dates from 01/01/00 to 12/31/99
Unit of Temp	Permits selection of temperature displays in degrees Fahrenheit (°F) or degrees Celsius (°C). Default is °F.
Comm Address	For RS-485 communications (0 to 127). Default address is 0. RS-232 should have its own (programmable) password.
Baud Rate	Allows communications Baud Rate to be set (2400 to 19.2K). Default is 9600.
Software Version	Identifies the current software version of the control box (Ver 0.0 to Ver 9.9).

**INNOVATION MENU ITEM DESCRIPTIONS – Continued**

MENU LEVEL & OPTION	DESCRIPTION
<b>CONFIGURATION MENU</b>	
Internal Setpoint	Allows internal setpoint to be set . Default is 130°F.
Unit Type	Allows selection of KC Boiler, KC Boiler LN, BMK Boiler, BMK Boiler LN, BMK Boiler Dual, KC Water Heater, KC Water Heater LN, Water Heater 2010
Unit Size	Sets unit size from 0.5 to 6.0 MBTUs. Default is 1.0 MBTU.
Fuel Type	Allows selection of Natural Gas or Propane. Default is Natural Gas.
Heater Mode	It allows selection of: Constant Setpoint, or Remote Setpoint. Default is Constant Setpoint Mode.
Remote Signal	Used to set the type of external signal which will be used when operating in the Remote Setpoint Mode. The factory default is 4-20 mA/1-5V.
Outdoor Sensor	Allows outdoor sensor function to be enabled or disabled. Default is disabled.
Setpoint Lo Limit	Used to set the minimum allowable setpoint (40°F to Setpoint Hi Limit). Default is 60°F
Setpoint Hi Limit	Used to set the maximum allowable setpoint (Setpoint Lo Limit to 240°F). Default is 200°F.
Temp Hi Limit	This is the maximum allowable outlet temperature (40 to 240°F). Any temperature above this setting will turn off the unit. The temperature must then drop 5°F below this setting to allow the unit to run. Default Hi Limit is 160°F.
Max Valve Position	Sets the maximum allowable valve position for the unit (40% to 100%). Default is 100%.
Pump Delay Timer	Specifies the amount of time (0 to 30 min.) to keep the pump running after the unit turns off. Default is zero.
Aux Start On Dly	Specifies the amount of time to wait (0 to 120 sec.) between activating the Aux Relay (due to a demand) and checking the pre-purge string to start the heater. Default is 0 sec.
Failsafe Mode	Allows the Failsafe mode to be set to either Constant Setpoint or Shutdown. Default is Shutdown.
Analog Output	Must be set to Valve Pos 0-10V.
Lo Fire Timer	Specifies how long (2 to 600 sec.) to remain in the low fire position after ignition, before going to the desired output. Default is 2 sec.
Network Timeout	Specifies the timeout value (seconds) before a Modbus fault is declared. Available settings range from 5 to 999 seconds. Default is 30 seconds.
HI DB Setpt EN	Operating at a Valve Position below this value will inhibit the DEADBAND feature. When operating at a Valve Position below this value, the effective Setpoint is equal to Active Setpoint + DEADBAND HIGH. Setting range is from 0 to 100. (Default is 30)



**INNOVATION MENU ITEM DESCRIPTIONS - Continued**

MENU LEVEL & OPTION	DESCRIPTION
<b>CONFIGURATION MENU</b> (Cont.)	
Demand Offset	<p>This entry will reduce excessive ON/OFF cycling in AUTO mode. When this entry is a non-zero value, the unit will not turn on again until <i>Valve Position In</i> reaches the <i>Start Level</i> value AND the Outlet Temperature goes below the <i>Active Setpoint – Demand Offset</i>. In addition, the heater will fire at the 29% Valve Position level or below for a period of one minute.</p> <p>When this entry is set to zero, the unit will turn on again as soon as the <i>Valve Position in</i> reaches the <i>Start Level</i> value. There will not be a one minute delay when firing at the 29% Valve Position level.</p> <p>Setting range is 0 to 25. (Default is 0)</p>
Deadband High Deadband Low	<p>Deadband High and Deadband Low settings create an “Outlet Temperature” Zone. In which no Valve Position corrections will be attempted.</p> <p>The Deadband ZONE is defined as operating with an Outlet Temperature between Active Setpoint + Deadband High and Active Setpoint – Deadband Low.</p> <p>When the Outlet Temperature reaches Active Setpoint and remains there for a period of 15 seconds, the unit will go into a DEADBAND MODE at which point no Valve Position corrections will be attempted while the Outlet Temperature remains anywhere within the Deadband ZONE. When the unit is in the DEADBAND MODE, the °F or °C LED will flash on and off. When the Outlet Temperature drifts out of the Deadband ZONE, the DEADBAND MODE will be terminated and the PID LOOP will again attempt Valve Position corrections.</p> <p>Setting range is 0 to 25. (Default is 0 for both Deadband High and Deadband Low)</p>

**INNOVATION MENU ITEM DESCRIPTIONS - Continued**

MENU LEVEL & OPTION	DESCRIPTION
<b><u>WHM MENU</u></b>	
WHM Mode	This option is used to enable/disable the WHM Mode and set the unit to function as a WHM Slave, or WHM Master. (Default = Off)
WHM Setpoint	This is the temperature (°F) that each unit in the WHM system is trying to control to. (Default = 130°F)
WHM Nxt On VP (See NOTE at end of page)	This is the Next On A/F Valve position (%) for the system. When all enabled water heaters have a fire rate greater than this value, it is time to enable another water heater, if one is available. This value should always be greater than the Next Off A/F Valve, and there should be a reasonable spread between the 2 values. (Default = + 65%)
WHM Nxt Off VP (See NOTE at end of page)	This is the Next Off A/F Valve position (%) for the system. When all enabled water heaters have a A/F Valve position greater than this value, it is time to enable another water heater, if one is available. This value should always be greater than the Next Off A/F Valve position, and there should be a reasonable spread between the 2 values. (Default = + 35%)
Lead/Lag Hours	The Lead/Lag Hours menu option is basically designed spread the total number of run hours accumulated on all units in the system so that each of the units have approximately the same number of run hours. The default value for this option is 72 hours,
Setback Setpoint	This is the setpoint temperature (°F) that each unit in the WHM system is trying to control to during periods of low (or no) DHW demand. The setback setpoint temperature can be set from 40°F to 220°F (Default = 130°F)
Setback Start: Setback End:	Specifies the start and end times that the Setback Setpoint will be in effect. (12:00am – 11:59pm)
WHM Auto Mstr	Enables (Yes) or disables (No) an Automatic WHM Master Switch-Over function. When enabled (Yes) the WHM will automatically select a new Master if the current Mater fails or loses power. Default = No (Disabled)
WHM Auto Timer	When the WHM Auto Mstr option is set to Yes (Enabled), the WHM Auto Timer option allows the user to select the elapsed time interval between failure of the WHM Master and switch-over to a new WHM Master. The default for this option is 30 seconds. The allowable entry range is 10 seconds to 120 seconds.

**NOTE**

The WHM Nxt On VP and WHM Nxt Off VP will determine how tight a range the temperature is controlled over and how quickly the system responds to a change in load. A narrow difference between Nxt On VP and WHM Nxt Off VP will make the system more responsive to load changes.

**INNOVATION MENU ITEM DESCRIPTIONS - Continued**

MENU LEVEL & OPTION	DESCRIPTION
<b>TUNING MENU</b>	
Prop Band	Generates a valve position based on the error that exists between the setpoint temperature and the actual outlet temperature. If the actual error is less than the proportional band setting (1 to 120°F), the valve position will be less than 100%. If the error is equal to or greater than the proportional band setting, the valve position will be 8%.
Integral Gain	This sets the fraction of the output, due to setpoint error, to add or subtract from the output each minute to move towards the setpoint. Gain is adjustable from 0.00 to 1.00 (Default is 1.6).
Derivative Time	This value (0.0 to 20.0 min.) responds to the rate of change of the setpoint error. This is the time that this action advances the output.
Min Load Adj	Setting is adjustable from -50°F to +50°F (Default is zero). It adjusts the output by adding an offset to the breakpoint chart at minimum flow. This is used to fine tune Feed-Forward (FFWD) output at low flow levels.
Max Load Adj	Setting is adjustable from -50°F to +50°F (Default is zero). It adjusts the output by changing the scaling of the breakpoint chart at maximum flow.
FFWD Temp	Displays the Feed-Forward temperature.
Outlet Feedback	Used to Enable or Disable feedback. Disable this function for Feed-Forward control only.
Feedback Gain*	Adjustable from 0.01 to 1.00 (Default is 0.05).
Breakpoint at 100% Thru Breakpoint at 0%	Allows breakpoint temperature settings (30°F to 240°F) to be entered for 100% to 0% in 10% increments. See Appendix D for default values.
Reset Defaults?	Allows Tuning Menu options to be reset to their Factory Default values.

\*Only displayed when Heater Tuning Display is enabled by factory authorized personnel.

This Page Is Intentionally Blank

**APPENDIX B: STARTUP, STATUS AND FAULT MESSAGES**

**TABLE B-1. STARTUP AND STATUS MESSAGES**

<b>MESSAGE</b>	<b>DESCRIPTION</b>
DEMAND DELAY XX sec	Displayed if Demand Delay is active.
DISABLED HH:MM pm, pm MM/DD/YY	Displayed if ON/OFF switch is set to OFF. The display also shows the time (am or pm) and date that the unit was disabled.
FLAME PROVEN	Displayed after flame has been detected for a period of 2 seconds. Initially, the flame strength is shown in %. After 5 seconds has elapsed, the time and date are shown in place of flame strength.
IGNITION TRIAL XX sec	Displayed during ignition trial of startup sequence. The duration of cycle counts up in seconds.
PURGING XX sec	Displayed during the purge cycle during startup. The duration of the purge cycle counts up in seconds.
STANDBY	Displayed when ON/OFF switch is in the ON position, but there is no demand for heat. The time and date are also displayed.
WAIT	Prompts the operator to wait.
WARMUP XX sec	Displayed for 2 minutes during the initial warm-up only.

**TABLE B-2. FAULT MESSAGES**

<b>FAULT MESSAGE</b>	<b>FAULT DESCRIPTION</b>
AIRFLOW FAULT DURING PURGE	The Blower Proof Switch opened during purge, or air inlet is blocked.
AIRFLOW FAULT DURING IGN	The Blower Proof Switch opened during ignition.
AIRFLOW FAULT DURING RUN	The Blower Proof Switch opened during run.
DELAYED INTERLOCK OPEN	The Delayed Interlock is open.
DIRECT DRIVE SIGNAL FAULT	The direct drive signal is not present or is out of range.
FFWD TEMP SENSOR FAULT	The temperature measured by the Feed Forward (FFWD) Sensor is out of range.
FLAME LOSS DURING IGN	The Flame signal was not seen during ignition or lost within 5 seconds after ignition.
FLAME LOSS DURING RUN	The Flame signal was lost during run.
HEAT DEMAND FAILURE	The Heat Demand Relays on the Ignition board failed to activate when commanded.
HIGH EXHAUST TEMPERATURE	The High Exhaust Temperature Limit Switch is closed.
HIGH GAS PRESSURE	The High Gas Pressure Limit Switch is open.
HIGH WATER TEMPERATURE	The temperature measured by the Outlet Sensor exceeded the Temp Hi Limit setting.
HIGH WATER TEMP SWITCH OPEN	The High Water Temperature Limit Switch is open.
IGN BOARD COMM FAULT	A communication fault has occurred between the PMC board and Ignition board.
IGN SWTCH CLOSED DURING PURGE	The Ignition Position Limit switch on the Air/Fuel Valve closed during purge.
IGN SWTCH OPEN DURING IGNITION	The Ignition Position Limit switch on the Air/Fuel Valve opened during ignition.
INTERLOCK OPEN	The Remote Interlock is open.
LINE VOLTAGE OUT OF PHASE	The Line (Hot) and Neutral wires are reversed.
LOW GAS PRESSURE	The Low Gas Pressure Limit Switch is open.
LOW WATER LEVEL	The Low Water Cutoff board is indicating low water level.
NETWORK COMM FAULT	The RS-485 network information is not present or is corrupted.

**TABLE B-2. FAULT MESSAGES - Continued**

FAULT MESSAGE	FAULT DESCRIPTION
OUTDOOR TEMP SENSOR FAULT	The temperature measured by the Outdoor Air Sensor is out of range.
OUTLET TEMP SENSOR FAULT	The temperature measured by the Outlet Sensor is out of range: <ul style="list-style-type: none"> <li>• OUTLET TEMPERATURE display = SHt Indicates sensor is shorted</li> <li>• OUTLET TEMPERATURE display = OPn indicates sensor is open-circuited</li> </ul>
PRG SWTCH CLOSED DURING IGNITION	The Purge Position Limit Switch on the Air/Fuel Valve closed during ignition.
PRG SWTCH OPEN DURING PURGE	The Purge Position Limit Switch on the Air/Fuel Valve opened during purge.
RECIRC PUMP FAILURE	Internal Recirculation Pump has failed.
REMOTE SETPT SIGNAL FAULT	The Remote Setpoint signal is not present or is out of range.
RESIDUAL FLAME	The Flame signal was seen for more than 60 seconds during standby.
SSOV SWITCH OPEN	The SSOV switch opened during standby.
SSOV FAULT DURING PURGE	The SSOV switch opened during purge.
SSOV FAULT DURING IGN	The SSOV switch closed or failed to open during ignition.
SSOV FAULT DURING RUN	The SSOV Switch closed for more than 15 seconds during Run.
SSOV RELAY FAILURE	A failure has been detected in one of the relays that control the SSOV.
STEPPER MOTOR FAILURE	The Stepper Motor failed to move the Air/Fuel Valve to the desired position.
WARNING EXHAUST TEMP HIGH (Flashing)	The exhaust gas sensor is measuring high temperature. Level #1: 180°F, Flash WARNING Level #2: 190°F, Govern fire rate/flash WARNING Level #3: 200°F, Shut down unit (requires manual reset)

This Page Is Intentionally Blank



**APPENDIX C: TEMPERATURE SENSOR RESISTANCE/VOLTAGE CHART**

**TEMPERATURE SENSOR RESISTANCE/VOLTAGE CHART  
 (BALCO)**

TEMP (°F)	RES (OHMS)	VOLTS*
-40	779.0	1.93
-30	797.5	1.96
-20	816.3	1.99
-10	835.4	2.02
0	854.8	2.05
10	874.6	2.07
20	894.7	2.10
30	915.1	2.12
40	935.9	2.15
50	956.9	2.17
60	978.3	2.20
70	1000.0	2.23
80	1022.0	2.25
90	1044.4	2.27
100	1067.0	2.30
110	1090.0	2.32
120	1113.3	2.34
130	1137.0	2.36
140	1160.9	2.39
150	1185.2	2.41
160	1209.5	2.43
170	1234.7	2.45
180	1260.0	2.47
190	1285.6	2.50
200	1311.4	2.52
210	1337.7	2.54
220	1364.2	2.56
230	1391.0	2.58
240	1418.2	
250	1445.7	

\*Voltage at AUX & Common terminals in the I/O Box

This Page Is Intentionally Blank

**APPENDIX D: INNOVATION DEFAULT SETTINGS**

MENU & OPTION	FACTORY DEFAULT
<b><u>Setup Menu</u></b>	
Password	0
Language	English
Unit of Temp	Fahrenheit
Comm Address	0
Baud Rate	9600
<b><u>Configuration Menu</u></b>	
Internal Setpt	130°F
Unit Type	Innovation WH
Unit Size	600 MBH, 800 MBH, 1060 MBH, 1350 MBH
Fuel Type	Natural Gas
Heater Mode	Constant Setpoint
Remote Signal (If Heater Mode = Remote Setpoint)	4 – 20 mA ,/ 1-5V
Outdoor Sensor	Disabled
Setpt Lo Limit	60°F
Setpt Hi Limit	200°F
Temp Hi Limit	160°F
Max Valve Position	100%
Aux Start On Dly	0 sec
Failsafe Mode	Shutdown
mA Output	Off
Lo Fire Timer	2 sec.
Setpt Limiting	Disabled
Setpt Limit Band	0°F
Network Timeout	30 seconds
HI DB Setpt En	30
Demand Offset	0
Deadband High	0
Deadband Low	0

**INNOVATION DEFAULT SETTINGS - Continued**

<b>MENU &amp; OPTION</b>	<b>FACTORY DEFAULT</b>
<b><u>Tuning Menu</u></b>	
Prop Band	8°F
Integral Gain	1.60
Derivative Time	0.10 min
Min Load Adj	0°F
Max Load Adj	0°F
FFWD Temp	N/A
Outlet Feedback	On
Feedback Gain	0.05
Breakpoint At 100%	85°F
Breakpoint At 90%	86°F
Breakpoint At 80%	87°F
Breakpoint At 70%	88°F
Breakpoint At 60%	89°F
Breakpoint At 50%	90°F
Breakpoint At 40%	94°F
Breakpoint At 30%	103°F
Breakpoint At 20%	118°F
Breakpoint At 10%	134°F
Breakpoint At 0%	136°F
Reset Defaults?	No

**APPENDIX E: PARTS LIST DRAWINGS**

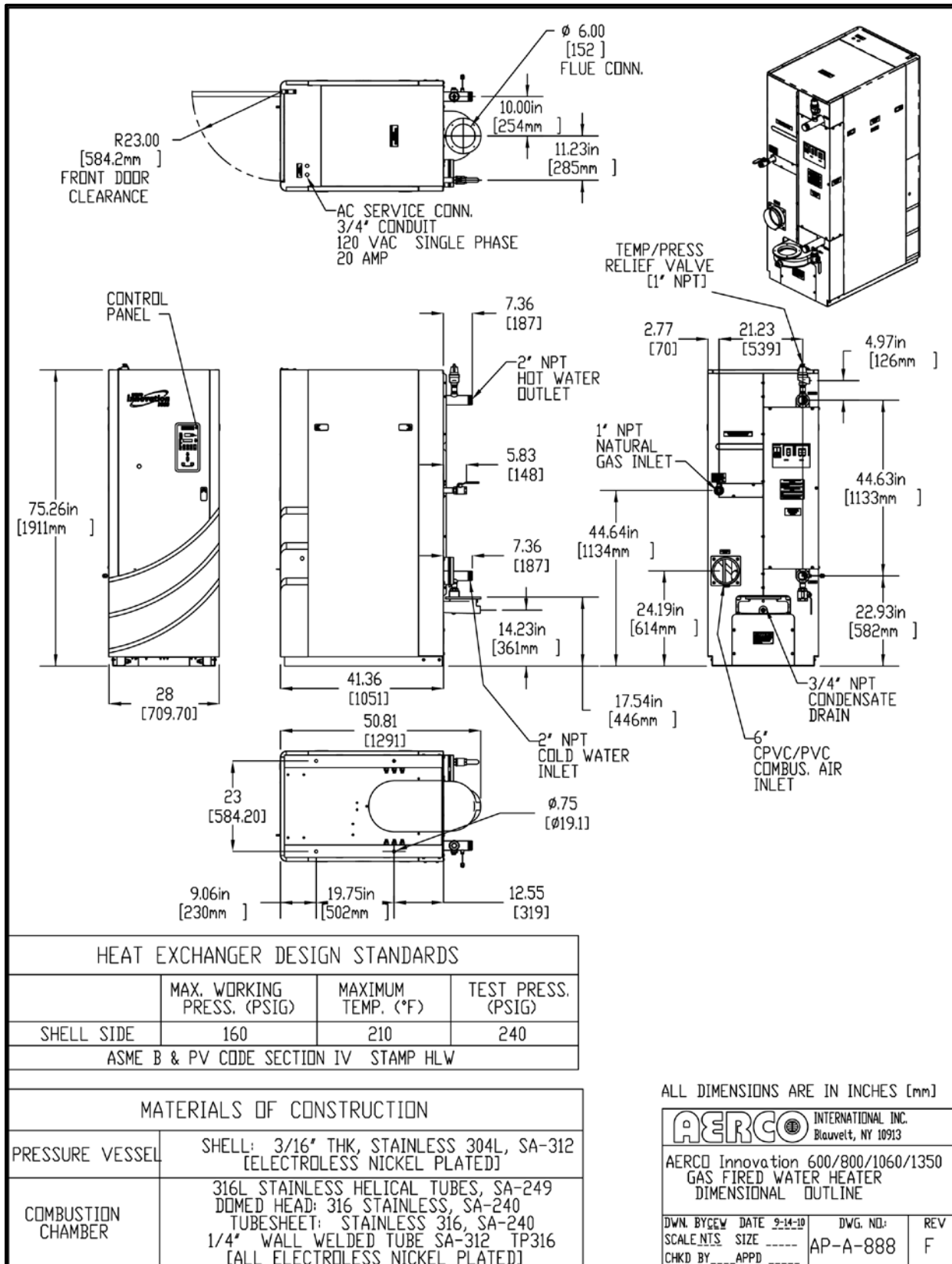

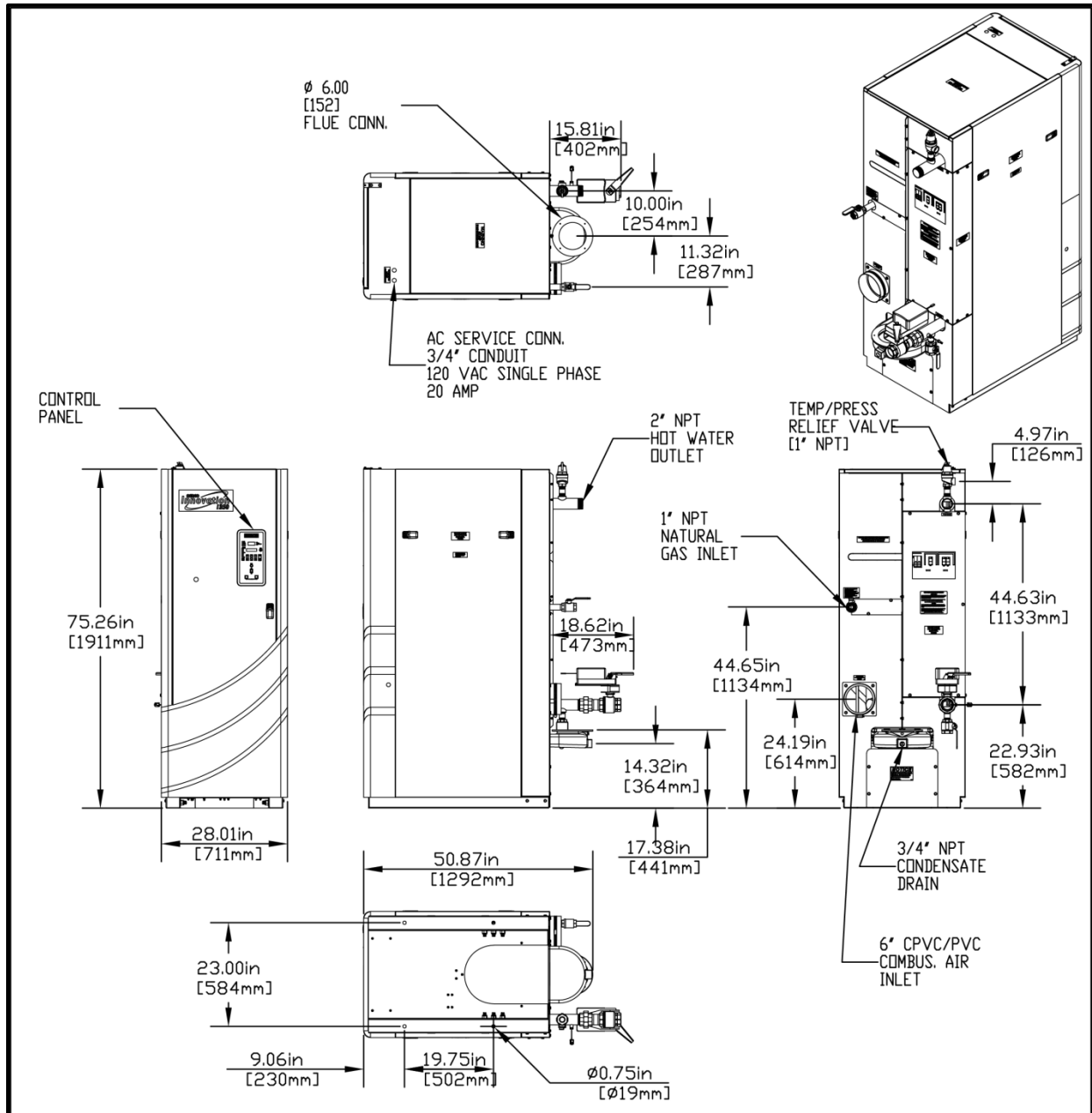

HEAT EXCHANGER DESIGN STANDARDS			
	MAX. WORKING PRESS. (PSIG)	MAXIMUM TEMP. (°F)	TEST PRESSURE (PSIG)
SHELL SIDE	160	210	240
ASME B & PV CODE SECTION IV STAMP HLW			
MATERIALS OF CONSTRUCTION			
PRESSURE VESSEL	SHELL: 3/16" THK, STAINLESS 304L, SA-312 (ELECTROLESS NICKEL PLATED)		
COMBUSTION CHAMBER	316L STAINLESS HELICAL TUBES, SA-249		
	DOMED HEAD: 316 STAINLESS, SA-240 TUBESHEET: STAINLESS 316, SA-240 1/4" WALL WELDED TUBE SA-312 TP316 [ALL ELECTROLESS NICKEL PLATED]		

**AERCO** INTERNATIONAL INC.  
Blauvelt, NY 10913

AERCO INN 600/800/1060/1350  
GAS FIRED WATER HEATER  
WITH SEQUENCING VALVE  
DIMENSIONAL OUTLINE

DNW BY: _HM	DATE: 4/11/12	DWG. NO.:	REV
SCALE: _NTS	SIZE: _	AP-A-902	A
CHKD BY: _	APPD: _		

ITEM NO.	QTY.	PART NUMBER	DESCRIPTION
1	1	92036	VALVE, SSOV 1" NPT
2	1	69005	ACTUATOR ASSY, SSOV W/ REGULATOR
3	2	94028-3.00	NIPPLE, 1" NPT TBE X 3.00 LG
4	2	12951-2	BUSHING, CONTROL BOX
5	1	61002-1	LOW GAS PRESSURE SWITCH, 2.6" W.C.
6	3	99014	NIPPLE, HEX 1/4 NPT X 3/8 NPT
7	1	99015	DAMPING ORIFICE, SSOV
8	2	123536	BUSHING, REDUCING 1/4 X 1/8 NPT
9	1	61002-4	PRESS. SWITCH 4.0" W.C. RISE N.C.
10	1	123542	FLANGE 2" 125# 2"NPT
11	2	93035	ELBOW, STREET 1/4 NPT
12	1	92006-5	VALVE, BALL 1" NPT
13	1	8-31	BUSHING, REDUCING 1" X 2"
14	1	94028-7.00	NIPPLE, 1" NPT TBE X 7.00 LG
15	2	93181	ELBOW, STREET 1" NPT
16	1	161450	HARNES. WIRING, GAS TRAIN
17	1	124862	RESISTOR ASSY
18	1	94028-2.50	NIPPLE, 1" NPT TBE X 2.50 LG
19	1	93238	ELBOW 1" NPT M/I
20	1	94028-24.00	NIPPLE, 1" NPT PIPE X 24" LG
21	1	92077	1/4" NPT M/F BRASS BALL VALVE (OPEN)
22	3	93290	TEE M/F M/F BLACK IRON 1/4" NPT
23	2	92077	1/4" NPT M/F BRASS BALL VALVE (CLOSED)
24	2	9-22	PIPE PLUG, 1/4" NPT, STEEL
25	1	93315	TEE RDCG 1" x 1/2" x 1" M.I.
26	1	9-43	BUSHING, REDUCING 1/2 X 1/4 NPT
27	1	123771	UNION, MA x FEM 1" NPT, 150# M.I.
28	1	97005-5	TUBE, FLEXIBLE GAS 18"

69005, 124862, & 99015 ARE SUPPLIED AS A KIT.  
 ORDER KIT #64048

**AERCO** INTERNATIONAL INC.  
 Blauvelt, NY 10913

**INNOVATION GFWH  
 FM GAS TRAIN**

DWN.BY	GEW. DATE	5-26-11	REV.	B
SCALE	N/T	SIZE	A	
CHKD.		APPD.		
REV. DATE				AP-A-896

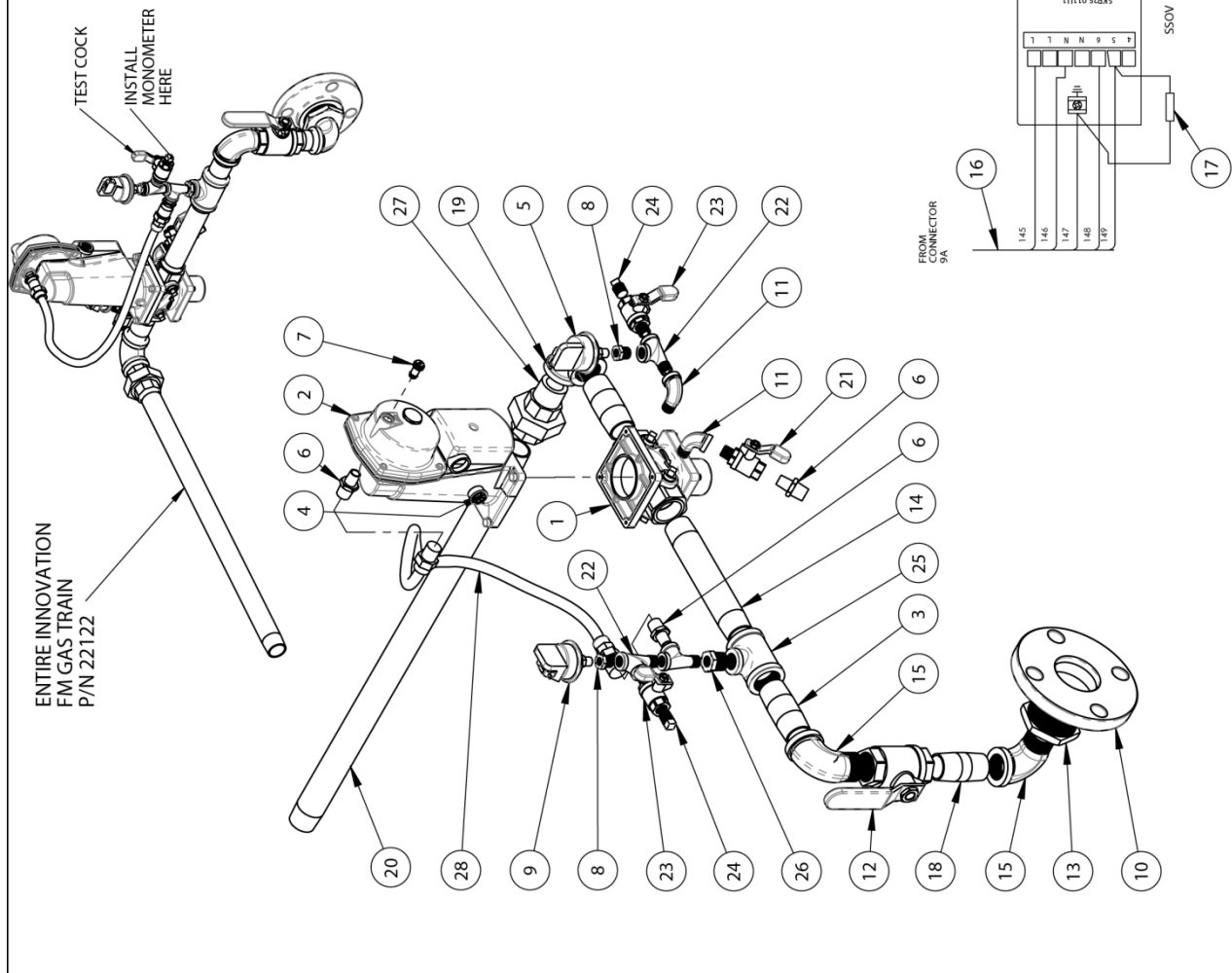

ITEM NO.	QTY.	PART NUMBER	DESCRIPTION
1	1	123542	FLANGE 2" 125# 2"NPT
2	1	8-31	BUSHING, REDUCING 1" X 2"
3	2	93181	ELBOW, STREET 1" NPT
4	1	94028-3.00	NIPPLE, 1" NPT TBE X 3.00 LG
5	2	94028-2.50	NIPPLE, 1" NPT TBE X 2.50 LG
6	1	94028-24.00	NIPPLE, 1" NPT TBE X 24" LG
7	1	94028-5.25	NIPPLE, 1" NPT TBE X 5.25 LG
8	1	92006-5	VALVE, BALL 1" NPT
9	1	93315	TEE RDCG 1" x 1/2" x 1" M.I.
10	1	69005	ACTUATOR, SSOV W/ REGULATOR
11	1	124150	VALVE, SSOV 1-1/2" NPT
12	1	123771	UNION, MA x FEM 1" NPT, 150# M.I.
13	1	93238	ELBOW 1" NPT M/I
14	1	9-43	BUSHING, REDUCING 1/2 X 1/4 NPT
15	3	93290	TEE MAXXF BLACK IRON 1/4" NPT
16	2	92077	1/4" NPT M X F BRASS BALL VALVE, CLOSED
17	2	9-22	PIPE PLUG, 1/4" NPT, STEEL
18	2	123536	BUSHING, REDUCING 1/4" X 1/8" NPT
19	1	93035	ELBOW, STREET 1/4" NPT
20	2	12951-2	BUSHING, CONTROL BOX
21	2	99014	NIPPLE, HEX 1/4" NPT X 3/8" NPT
22	1	161450	HARNES, WIRING, GAS TRAIN
23	1	124862	RESISTOR ASSY
24	2	8-22	BUSHING, REDUCING 1 1/2" F NPT X 1" M NPT
25	1	61002-12	HIGH GAS PRESSURE SWITCH 4.7" W.C.
26	1	61002-11	LOW GAS PRESSURE SWITCH 3.6" W.C.
27	1	97005-2	TUBE, FLEXIBLE GAS 12"

69005 & 124862 ARE SUPPLIED AS A KIT.  
ORDER KIT #64100



**INN1350  
INNOVATION FM GAS TRAIN**

DWN.BY	CEW	DATE	4/26/12	REV.	A
SCALE	NIS	SIZE	A		
CHKD.		APPD.			
REV. DATE			4-26-12		

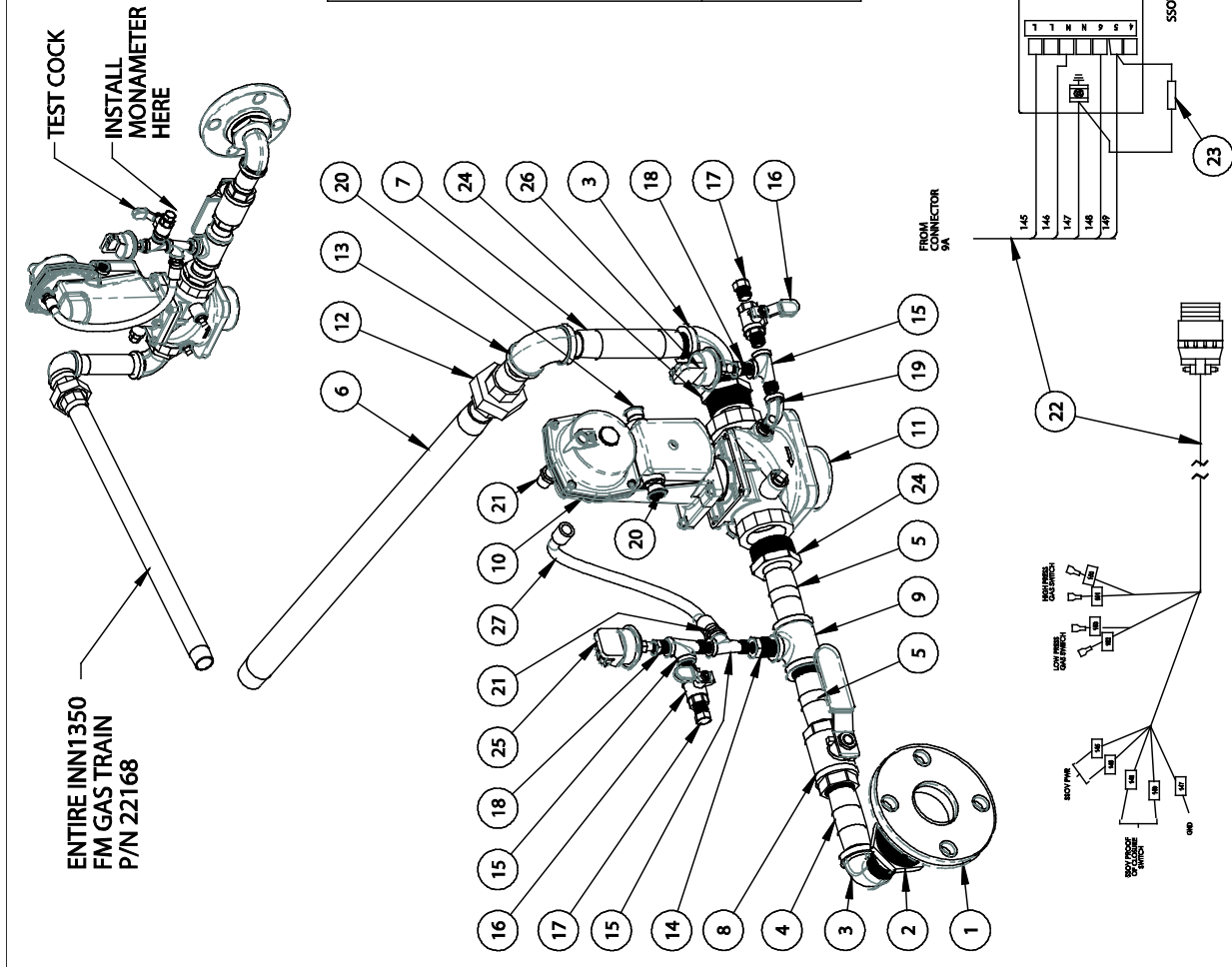



ITEM NO.	QTY.	PART NUMBER	DESCRIPTION
1	1	123542	FLANGE 2" 125# 2"NPT
2	1	8-31	BUSHING, REDUCING 1" X 2"
3	2	93181	ELBOW, STREET 1" NPT
4	1	94028-3.00	NIPPLE, 1" NPT TBE X 3.00 LG
5	2	94028-2.50	NIPPLE, 1" NPT TBE X 2.50 LG
6	1	94028-24.00	NIPPLE, 1" NPT TBE X 24" LG
7	1	94028-5.25	NIPPLE, 1" NPT TBE X 5.25 LG
8	1	92006-5	VALVE, BALL 1" NPT
9	1	93315	TEE RDCG 1" x 1/2" x 1" M.I.
10	1	69005	ACTUATOR, SSOV W/ REGULATOR
11	1	124150	VALVE, SSOV 1-1/2" NPT
12	1	123771	UNION, MA X FEM 1" NPT, 150# M.I.
13	1	93238	ELBOW 1" NPT M/I
14	1	9-43	BUSHING, REDUCING 1/2 X 1/4 NPT
15	3	93290	TEE MXPXF BLACK IRON 1/4" NPT
16	2	92077	1/4" NPT M X F BRASS BALL VALVE, CLOSED
17	2	9-22	PIPE PLUG, 1/4" NPT, STEEL
18	2	123536	BUSHING, REDUCING 1/4" X 1/8" NPT
19	1	93035	ELBOW, STREET 1/4" NPT
20	2	12951-2	BUSHING, CONTROL BOX
21	2	99014	NIPPLE, HEX 1/4" NPT X 3/8" NPT
22	1	161450	HARNES, WIRING, GAS TRAIN
23	1	124862	RESISTOR ASSY
24	2	8-22	BUSHING, REDUCING 1 1/2" F NPT X 1" M NPT
25	1	61002-12	HIGH GAS PRESSURE SWITCH 4.7" W.C.
26	1	61002-11	LOW GAS PRESSURE SWITCH 3.6" W.C.
27	1	97005-2	TUBE, FLEXIBLE GAS 12"

69005 & 124862 ARE SUPPLIED AS A KIT.  
 ORDER KIT #64100



**AERCO**  
 INTERNATIONAL INC.  
 Blauvelt, NY 10913

**INN1350**  
**INNOVATION FM GAS TRAIN**

DWN. BY	REV.	REV.	
GEW DATE 4/26/12	SIZE A	AP-A-905	A
SCALE	CHKD.	APPD.	
		4-26-12	



ITEM NO.	QTY.	PART NUMBER	DESCRIPTION	ITEM NO.	QTY.	PART NUMBER	DESCRIPTION
1	4	12951-2	BUSHING, CONTROL BOX	23	1	69038	ACTUATOR, SSOV W/O P.O.C. SWITCH
2	1	61002-11	LOW GAS PRESSURE SWITCH 3.6" W.C.	24	1	123148	BUSHING, 1" NPT X 3/4" NPT
3	2	99014	NIPPLE, HEX 1/4" NPT X 3/8" NPT	25	2	9-469	ELBOW, 90° 3/4" NPT
4	2	123536	BUSHING, REDUCING 1/4" X 1/8" NPT	26	1	94061-8.00	NIPPLE, 3/4" NPT X 8.00 LG
5	1	61002-12	HIGH GAS PRESSURE SWITCH 4.7" W.C.	27	1	122774	VALVE, VENT 3/4" NPT
6	1	123542	FLANGE 2" 125# 2"NPT	28	1	50005	3/4" PIPE SIZE CLAMP
7	1	93035	ELBOW, STREET 1/4" NPT	29	1	123774	1" PIPE SIZE CLAMP
8	1	92006-5	VALVE, BALL 1" NPT	30	1	94061-7.50	NIPPLE, 3/4" NPT X 3.00 LG
9	1	8-31	BUSHING, REDUCING 1" X 2"	31	1	94061-3.00	NIPPLE, 3/4" NPT X 3.00 LG
10	1	161450	HARNES, WIRING, GAS TRAIN	32	1	94061-19.00	NIPPLE, 3/4" NPT X 3.00 LG
11	1	124862	RESISTOR ASSY	33	1	59053	CHANNEL, STRUT
12	1	94028-24.00	NIPPLE, 1" NPT TBE X 24" LG	34	1	124024	HARNES, WIRING, IRI
13	3	93290	TEE, MXXFX BLACK IRON 1/4" NPT	35	1	9-465	TEE, 1" NPT
14	2	92077	1/4" NPT M X F BRASS BALL VALVE, CLOSED	36	1	94028-2.00	NIPPLE, 1" NPT TBE X 2.00 LG
15	2	9-22	PIPE PLUG, 1/4" NPT, STEEL	37	1	94028-3.50	NIPPLE, 1" NPT TBE X 3.50 LG
16	2	93181	ELBOW, STREET 1" NPT	38	1	93337	BUSHING, REDUCING 1x 1/4
17	1	123771	UNION, MA x FEM 1" NPT, 150# M.I.	39	1	90086	NIPPLE, 1" NPT PIPE X 1.5 LG SCH 40 [CLOSE]
18	1	97005-5	TUBE FLEXIBLE GAS 18"				
19	1	124137	VALVE, SSOV, DOUBLE BODY, 1-1/2" NPT				
20	2	8-22	BUSHING, REDUCING 1 1/2" F NPT X 1" M NPT				
21	2	124178	FLANGE, 1-1/2" SSOV				
22	1	69005	ACTUATOR, SSOV W/ REGULATOR				

ITEM NO.	QTY.	PART NUMBER	DESCRIPTION
23	1	69038	ACTUATOR, SSOV W/O P.O.C. SWITCH
24	1	123148	BUSHING, 1" NPT X 3/4" NPT
25	2	9-469	ELBOW, 90° 3/4" NPT
26	1	94061-8.00	NIPPLE, 3/4" NPT X 8.00 LG
27	1	122774	VALVE, VENT 3/4" NPT
28	1	50005	3/4" PIPE SIZE CLAMP
29	1	123774	1" PIPE SIZE CLAMP
30	1	94061-7.50	NIPPLE, 3/4" NPT X 3.00 LG
31	1	94061-3.00	NIPPLE, 3/4" NPT X 3.00 LG
32	1	94061-19.00	NIPPLE, 3/4" NPT X 3.00 LG
33	1	59053	CHANNEL, STRUT
34	1	124024	HARNES, WIRING, IRI
35	1	9-465	TEE, 1" NPT
36	1	94028-2.00	NIPPLE, 1" NPT TBE X 2.00 LG
37	1	94028-3.50	NIPPLE, 1" NPT TBE X 3.50 LG
38	1	93337	BUSHING, REDUCING 1x 1/4
39	1	90086	NIPPLE, 1" NPT PIPE X 1.5 LG SCH 40 [CLOSE]

69005 & 124862 ARE SUPPLIED AS A KIT. ORDER KIT #64100

ENTIRE INN1350 DBB GAS TRAIN P/N 22168-1

INSTALL MONOMETER HERE

TEST COCK

NOTE: CUT OFF CONNECTOR CONN. FROM VALVE BUT LEAVE TO REMAIN. WIRE # 14 FROM BODY #2

SSOV #1

SSOV #2

34

10

11

AERCO INTERNATIONAL INC.  
 Blauvelt, NY 10913

INN1350  
 INNOVATION DBB GAS TRAIN

DWN.BY	GEW	DATE	4/26/12
SCALE	NTS	SIZE	A
CHKD.		APPD.	
REV.		DATE	4-26-12

REV. **A**

AP-A-906

ITEM NO.	QTY.	PART NUMBER	DESCRIPTION
1	1	44107	BLOWER SIDE INTAKE MANIFOLD
2	1	44108	BLOWER-A/F VALVE ADAPTER
3	1	81064	GASKET, BLOWER
4	1	24111	BLOWER, AMETEK 8.9"
5	1	88004	O-RING #2-244 BUJANA-N
6	4	54028	SCREW, HEX HD, SERRATED 5/16-18
7	6	55071	SCREW, SOC HD M8 x 1.25 x 30mm LG.
8	1	81057	GASKET, BLOWER
9	1	24220-3	A/F VALVE ASSY
10	6	122371	1/4-20 X 1" LG HEX HD. MACHINE SCREW
11	1	124008	NIPPLE, 1/8 NPT X 3.00" LG
12	2	123535	TEE, 1/8" NPT
13	3	123534	PLUG, HEX 1/8 NPT
14	1	124979	1/8" C.S. STREET ELBOW
15	1	61002-5	BLOCKED INLET SWITCH -8.0" W.C.
16	1	60011-1	SWITCH ASSY, BLOWER PROOF
17	1	59138	FILTER, AIR 6"
18	1	61024	AIR INLET TEMPERATURE SENSOR
19	1	93367	SNUBBER, FAN PROVING SWITCH
20	1	90092	NIPPLE, 1/8 NPT x 4.50 LG SCH 40 BLACK

81057, 24220-3 & 88003 'O' RING #2-339  
[NOT SHOWN] ARE SUPPLIED AS A KIT.

ORDER KIT #24311-3

81064, 24111 & 81057 ARE SUPPLIED AS A KIT.

ORDER KIT #58039

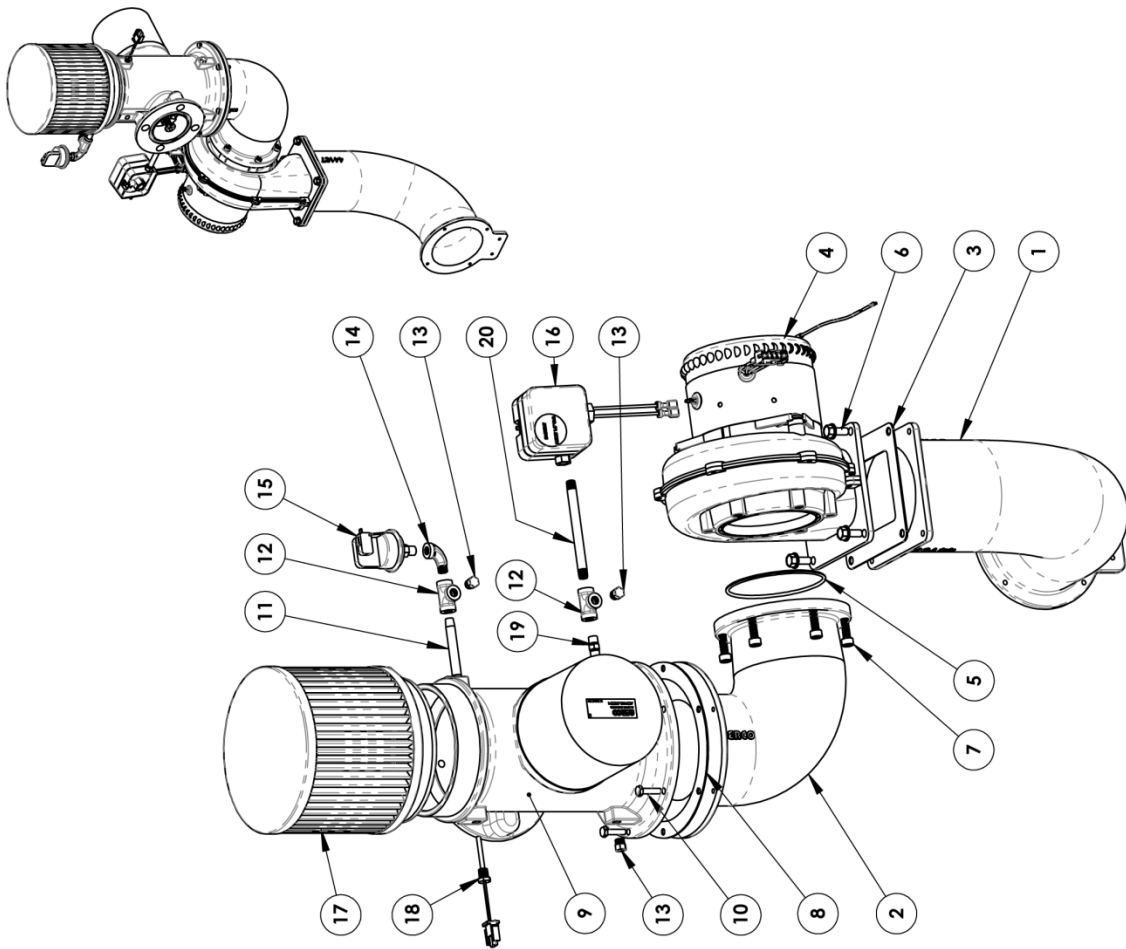

INNOVATION WATER HEATERS

**AERCO** INTERNATIONAL INC.  
Blauvelt, NY 10913

**INN600, INN800, INN1060**  
**AIR FUEL DELIVERY SYSTEM**  
**BLOWER, AIR FUEL VALVE, ACCESSORIES**

DWN BY: CEW	DATE: 5-27-11	REV.
SCALE: NTS	SIZE: A	
CHKD:	APPD:	<b>PL-A-164</b>
REV. DATE: 3-2-12		<b>C</b>



HEAT EXCHANGER			
ITEM	MODEL	PART NO.	QTY
1	INN600	24319-1	1
	INN800	24319-2	1
	INN1060	24319-3	1
DESCRIPTION PLATED HEAT EXCHANGER KIT			

DYNAMIC LOAD ANTICIPATOR ASSY			
ITEM	PART NO.	QTY	DESCRIPTION
2	69103	1	CIRCULATOR-1" CRIG TACO 007-SF5-IFC
3	59170	2	SHUT-OFF FREEDOM SWIVEL FLG 3/4" NPT
4	92082	1	T&P RELIEF VALVE 1" NPT
5	123449	3	TEMPERATURE SENSOR
6	92091	1	VALVE, BALL 1" NPT [DRAIN]

GAS TRAIN			
ITEM	PART NO.	QTY	DESCRIPTION
(2) 7	22122	1	STD FM GAS TRAIN
	22122-1	1	DBB GAS TRAIN

EXHAUST MANIFOLD			
ITEM	PART NO.	QTY	DESCRIPTION
8	44085	1	EXHAUST MANIFOLD
9	61020	1	SENSOR, EXHAUST TEMPERATURE

AIR FUEL DELIVERY SYTEM - BLOWER, A/F VALVE & ACCESS.			
ITEM	PART NO.	QTY	DESCRIPTION
10	24111	1	BLOWER - AMETEK 8.9"
(4) 11	24220-3	1	VALVE, AIR FUEL [NAT. GAS]
12	59138	1	FILTER, 6" AIR
13	61024	1	SENSOR, AIR INLET TEMP.
14	60011-1	1	SWITCH ASSY - BLOWER PROOF
15	61002-5	1	SWITCH - BLOCKED INLET 8.0" W.C.

BURNER			
ITEM	PART NO.	QTY	DESCRIPTION
16	24335-1	1	LOW NOx BURNER ASSY KIT
17	44086	1	LOW NOx BURNER MTG PLATE

ENCLOSURE - BASE- ELECTRICAL PANEL			
ITEM	PART NO.	QTY	DESCRIPTION
18	37094	1	FRONT PANEL ASSEMBLY
19	37098	1	PANEL, TOP
20	37097	1	PANEL, LEFT REAR
21	37081	1	COVER, 1" PIPE
22	37101	1	REAR PANEL, UPR RIGHT
23	37102	1	ACCESS PANEL, RIGHT REAR
24	37104	1	PANEL, RIGHT SIDE ZERO CLEARANCE
25	37103	1	LOWER PANEL, RIGHT REAR
26	37096	1	FRONT DOOR ASSEMBLY
27	37099	2	PANEL, SIDE
28	37063	1	PANEL, REAR LOWER
29	30081	1	PANEL, BASE COVER
30	34061	1	BASE, FORMED 26 X 40
31	39144	1	RING ASSY, LOWER HEAD
32	34063	2	LEG, BASE
33	30090	1	PANEL, ELECTRICAL

GASKETS / 'O'RINGS			
ITEM	PART NO.	QTY	DESCRIPTION
34	GP-18900	1	SEAL, MANIFOLD TO LWR HEAD
35	GP-122537	1	GASKET, EXH MANF TO COMB CHAMB
36	GP-18899	1	GASKET, BURNER FLANGE
37	81136	1	GASKET, INTAKE MANIFOLD
38	124749	1	GASKET, FIBRE FRAX
39	81150	1	GASKET, FLAME ROD
40	GP-18532	2	GASKET, SHELL 1/16
41	GP-18556	1	GASKET, RELEASE
42	GP-123077	1	LINER, UPPER HEAD
43	81064	1	GASKET, BLOWER
(4) 44	81057	1	GASKET, A/F VALVE
(1)(4) 45	88003	1	'O'-RING #2-339 [GAS TRAIN FLANGE]
(3) 46	88004	1	'O'-RING #2-244

CONTROLS			
ITEM	PART NO.	QTY	DESCRIPTION
47	64077	1	POWER BOX ASSEMBLY
48	65085	1	TRANSFORMER, GAS IGNITOR
(1) 49	65104	1	CABLE, HV IGNITION
(1) 50	63072	1	HARNESS, SHELL WIRING
(1) 51	63079	1	HARNESS, INNOVATION CONTROL
52	161560	1	I/O WIRING BOX ASSEMBLY
53	123552	1	SWITCH, OVER TEMP - MANUAL
54	123966	1	SWITCH, OVER TEMP - AUTO
55	122843	1	SENSOR, LOW WATER CUTOFF
56	181197	1	C-MORE CONTROL BOX
(1) 57	161450	1	HARNESS, GAS TRAIN MAIN WIRING [FM & DBB]
(1) 58	124024	1	HARNESS, DBB GAS TRAIN

OTHER PARTS			
ITEM	PART NO.	QTY	DESCRIPTION
59	59133	5	LATCH, COMPRESSION
60	32142-1	1	BAFFLE ASSY, HT EXCHANGER
61	74018	1	INN600 LOGO LABEL
	74019	1	INN800 LOGO LABEL
	74020	1	INN1060 LOGO LABEL
62	GP-161151	1	LINER, COMBUSTION CHAMB
63	49209	1	SHIELD, CONDENSATE
64	33132	1	GAS TRAIN BASE MOUNT BRKT
65	33133	1	PIPE SUPPORT BRACKET
66	55064	2	U-BOLT 1" PIPE
67	33114	1	GAS TRAIN LOWER BRKT
68	33115	1	GAS TRAIN UPPER BRKT
69	52031	27	STUD 5/8-11 X 3-3/4
70	56061	64	HEX NUT 5/8-11
71	53037	64	FLAT WASHER 5/8
72	52029	2	STUD 5/8-11 X 4-1/2
73	52030	3	STUD 5/8-11 X 7-3/4

NOTES:

- (1) NOT SHOWN IN DRAWING
- (2) FOR PICTORAL PURPOSES ONLY, FM GAS TRAIN [NON DUAL FUEL] IS SHOWN.
- (3) SEE DRAWING PL-A-164
- (4) 81057, 88003, & 24220-3 ARE SUPPLIED AS A KIT. ORDER KIT #24311-2

			
<b>INNOVATION WATER HEATER</b>			
<b>PARTS LIST</b>			
DWG. NO.:	DATE	SCALE	REV
PL-A-167		PL-A-167	B
CHKD BY:	APPD	SHEET 1 OF 4	

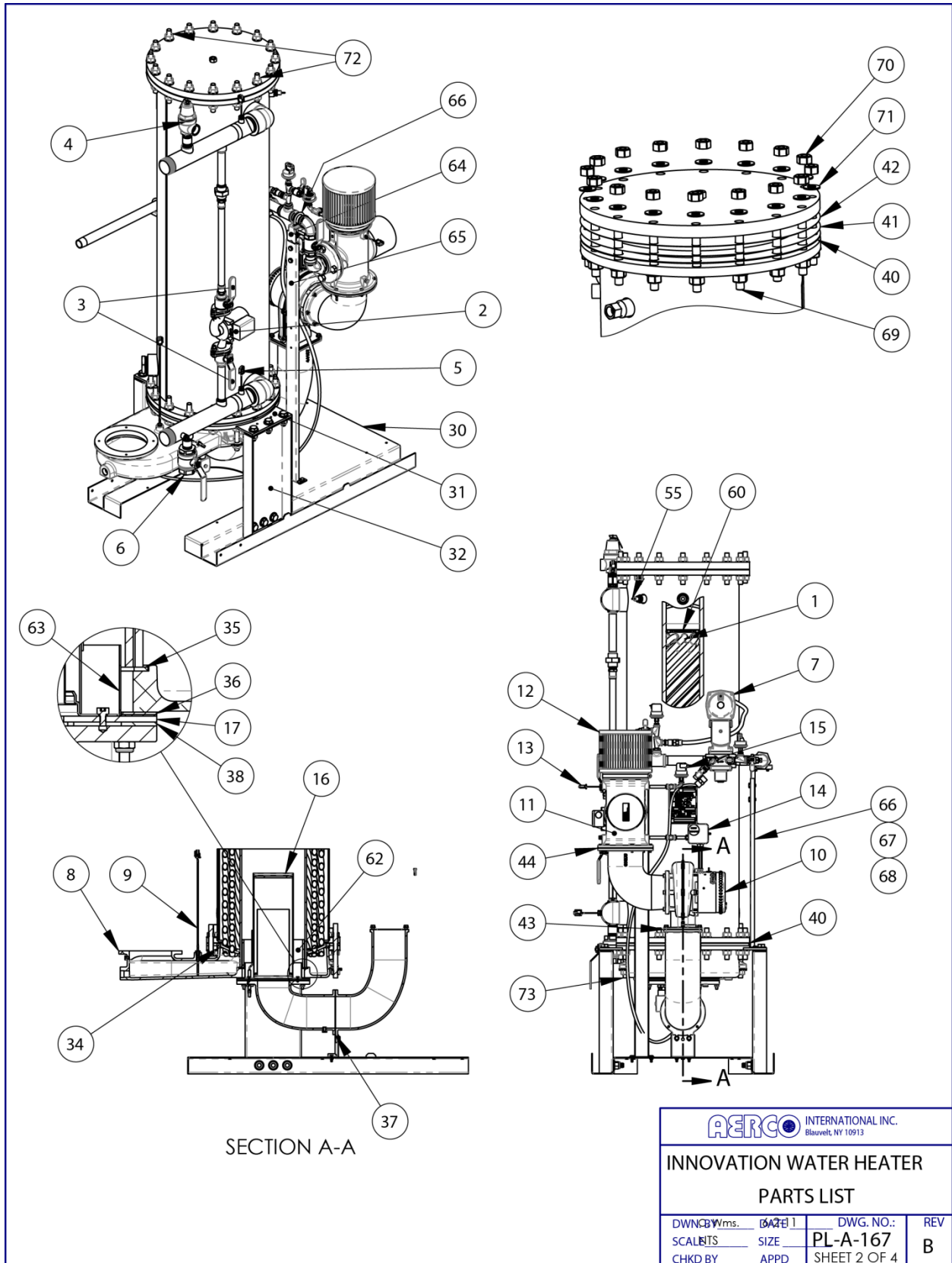

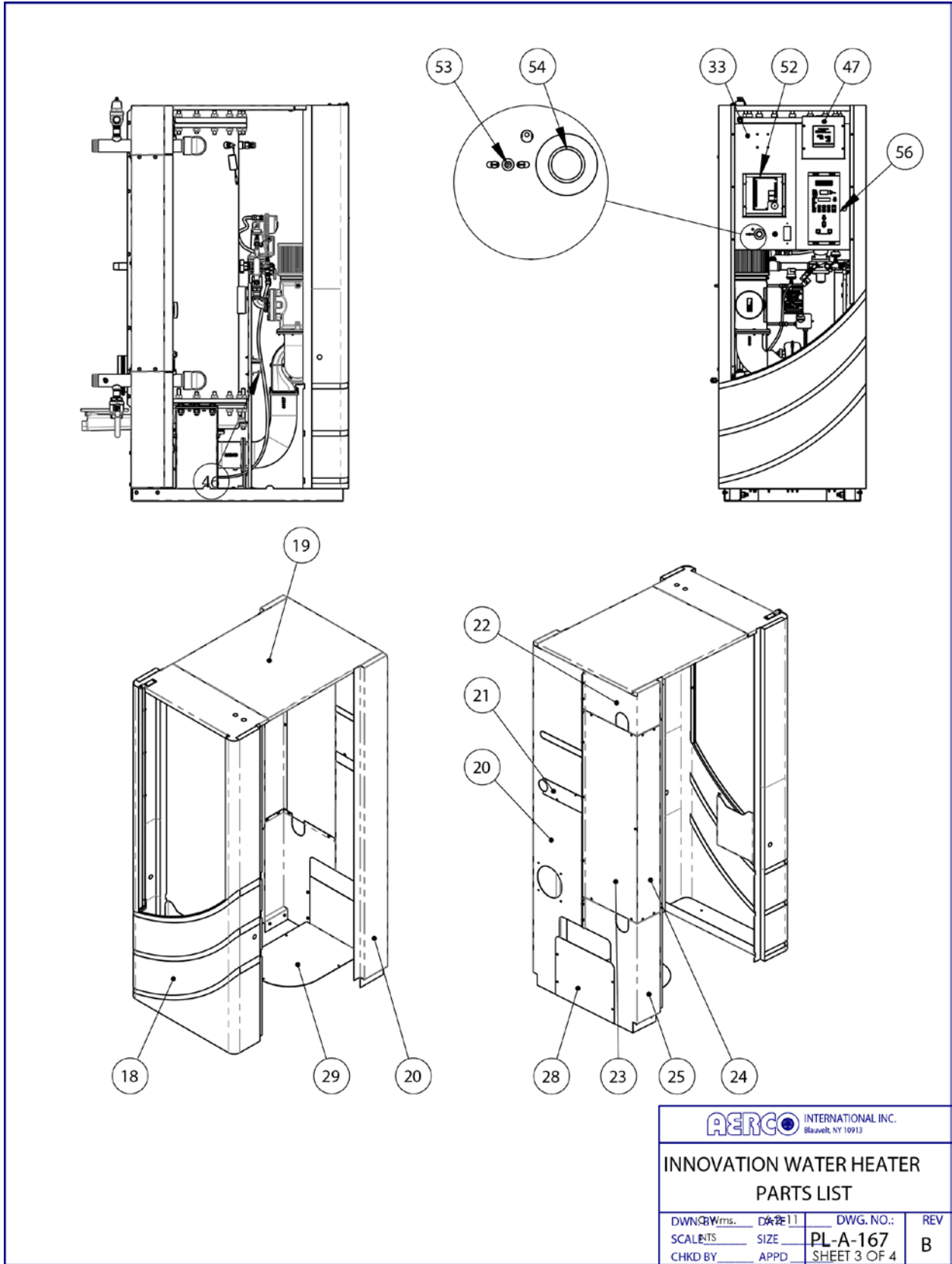



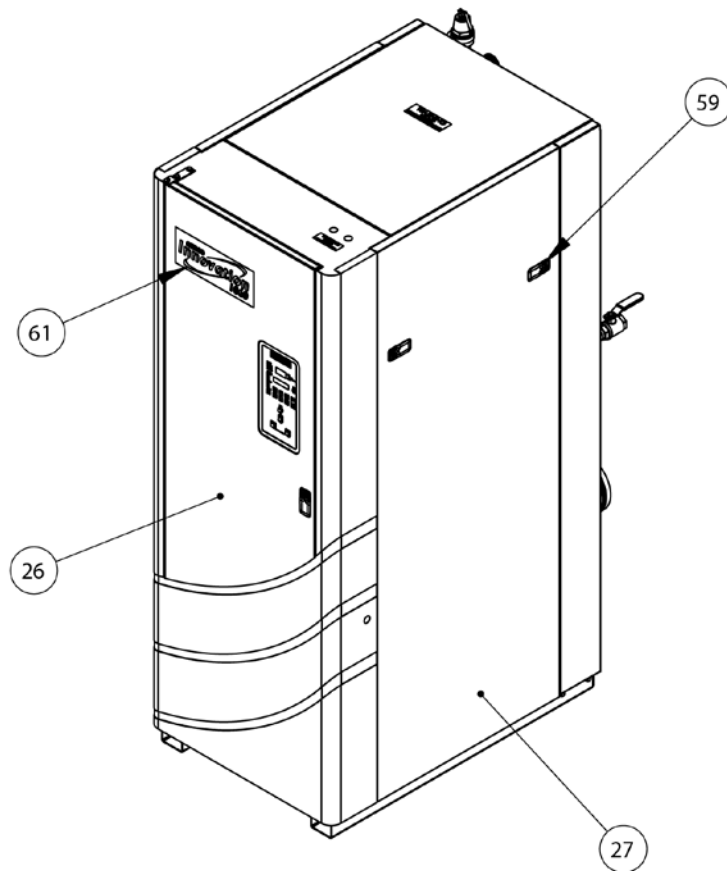

			
<b>INNOVATION WATER HEATER          PARTS LIST</b>			
DWG. NO.	SCALE	DWG. NO.	REV
PL-A-167	1/8" = 1'-0"	PL-A-167	B
CHKD BY	APPD	SHEET 4 OF 4	

This Page Is Intentionally Blank

**APPENDIX F: PIPING DRAWINGS**

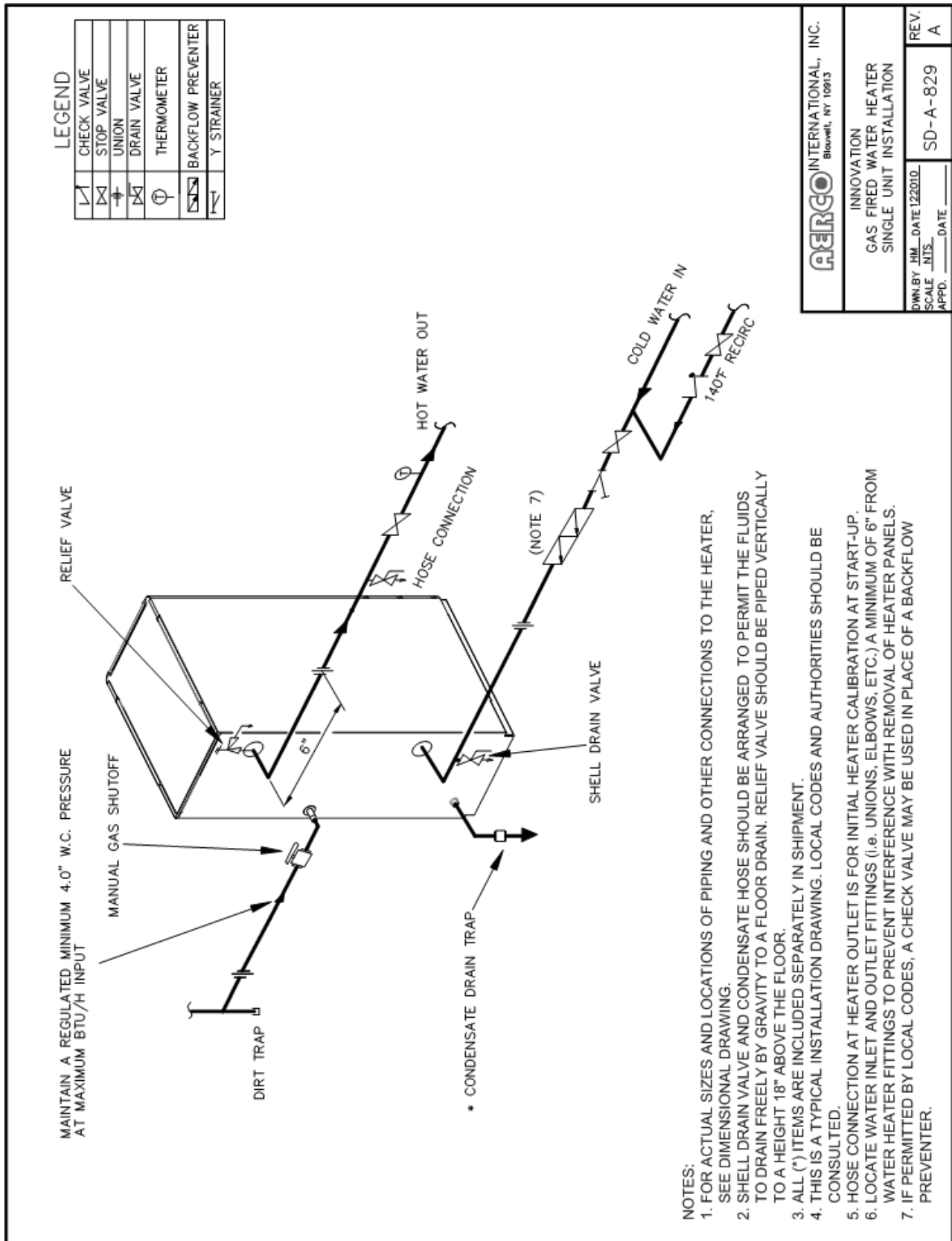

**PIPING DRAWINGS**

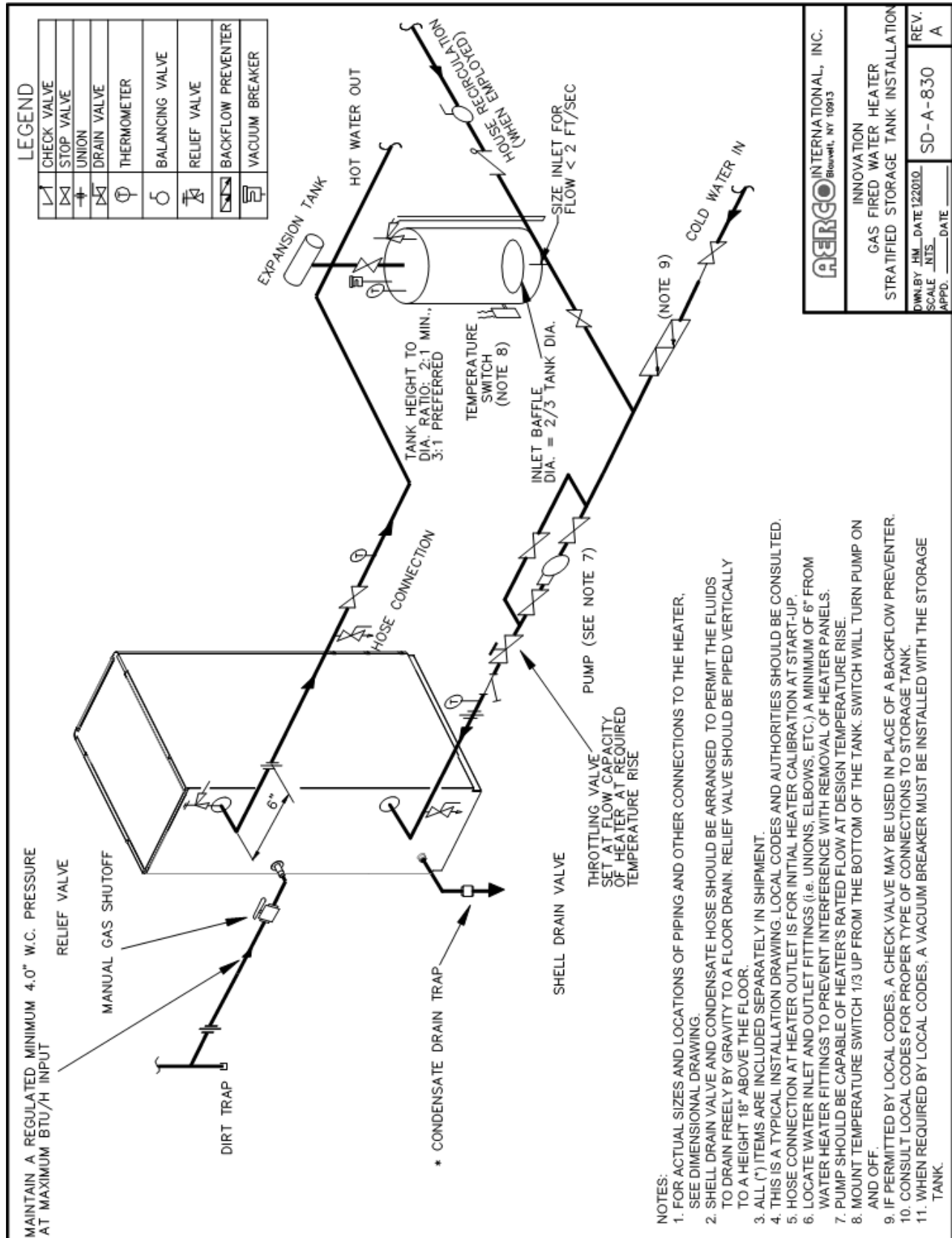

PIPING DRAWINGS

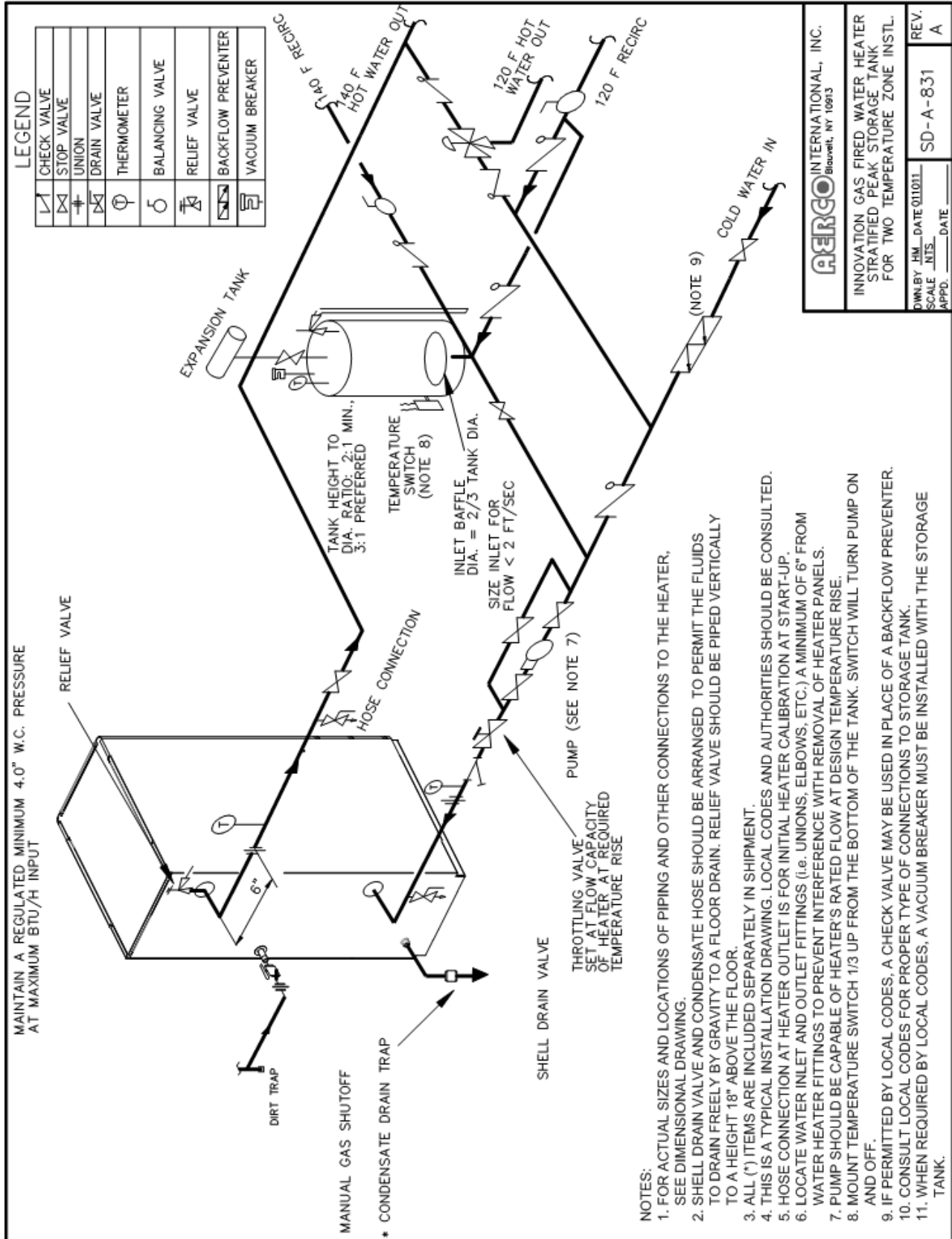

**PIPING DRAWINGS**

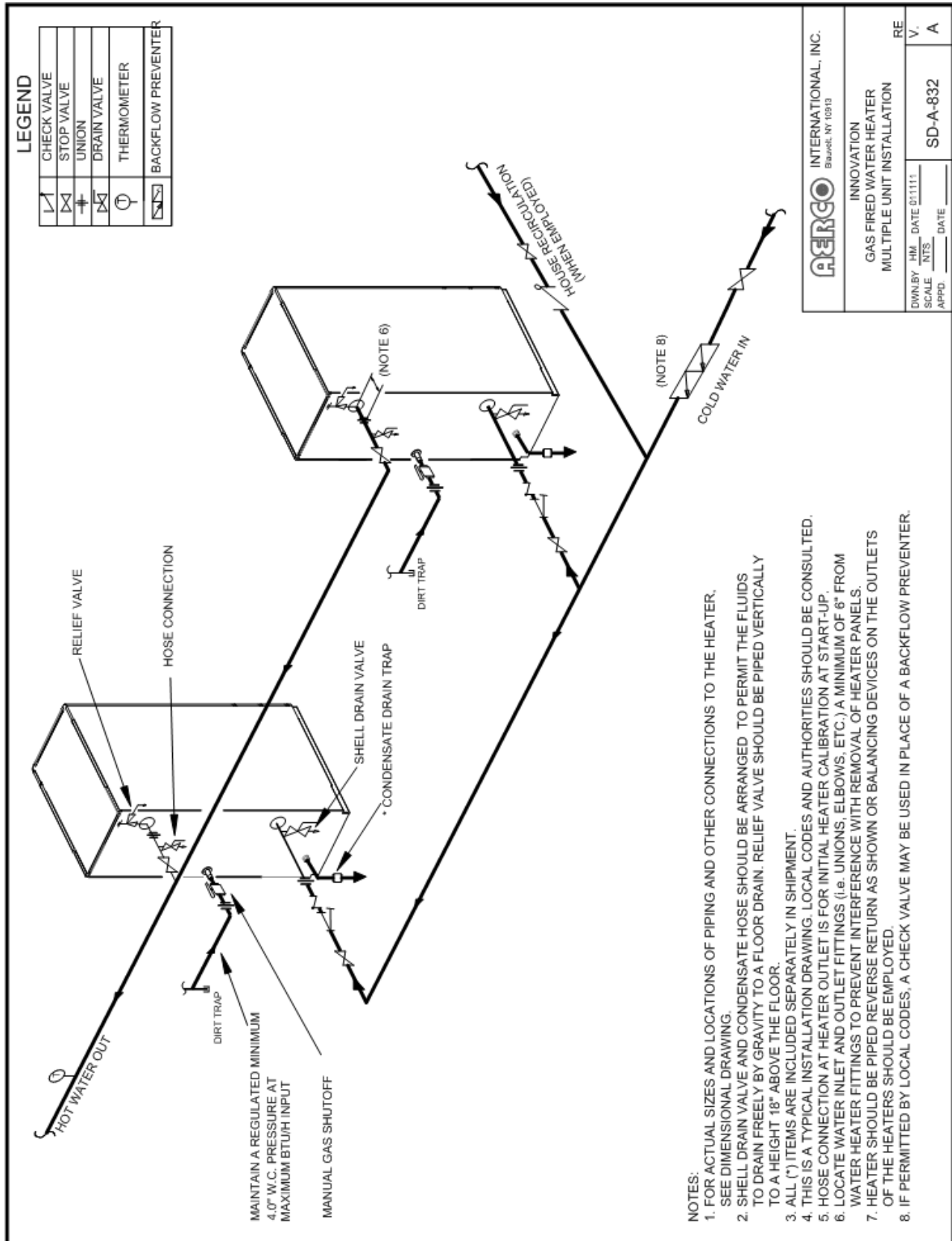

**PIPING DRAWINGS**

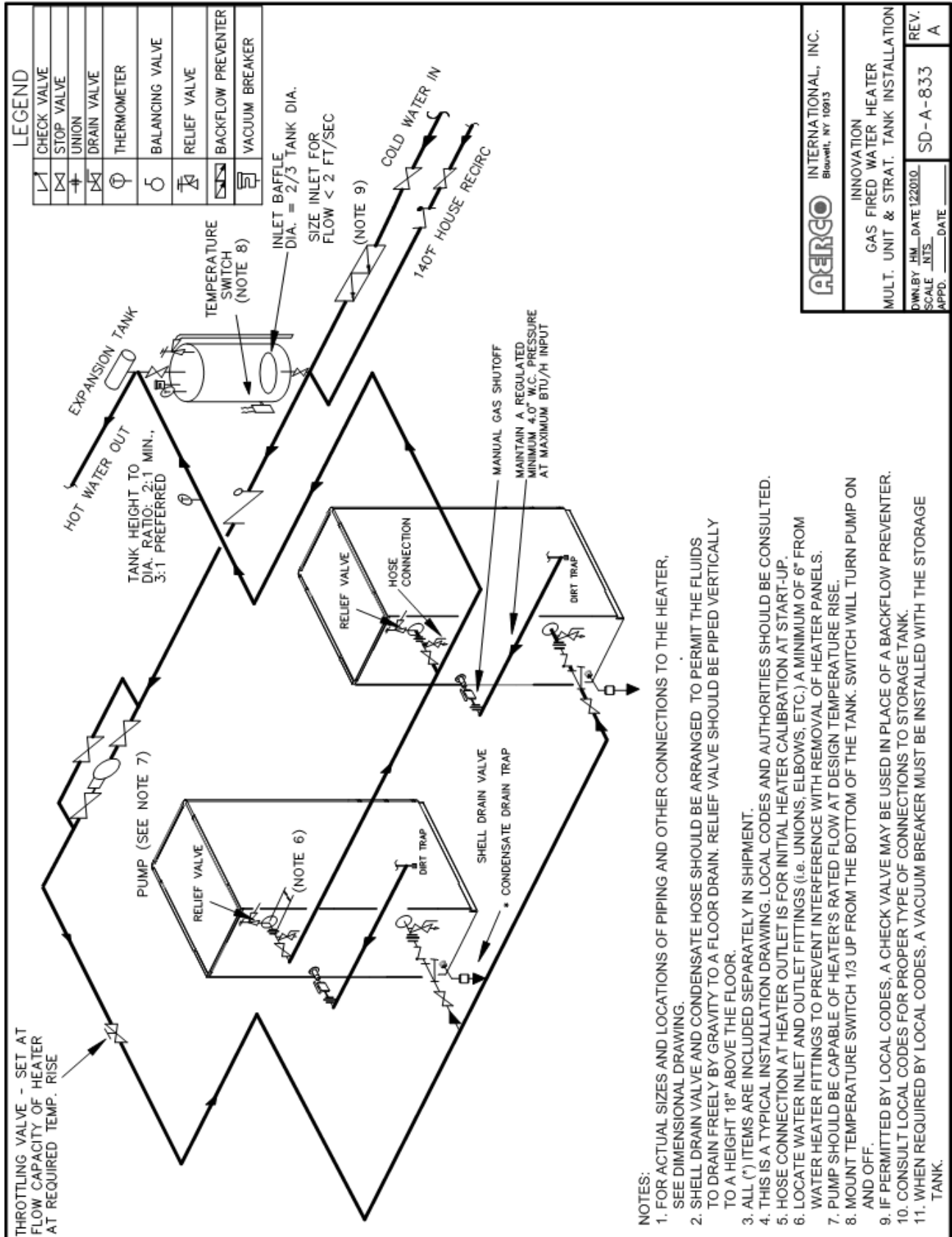

<b>AERCO</b> INTERNATIONAL, INC. Blauvelt, NY 10913	
INNOVATION GAS FIRED WATER HEATER MULT. UNIT & STRAT. TANK INSTALLATION	
DWN BY: HM	DATE: 122010
SCALE: NTS	REV. A
APPD: _____	SD-A-833

**PIPING DRAWINGS**

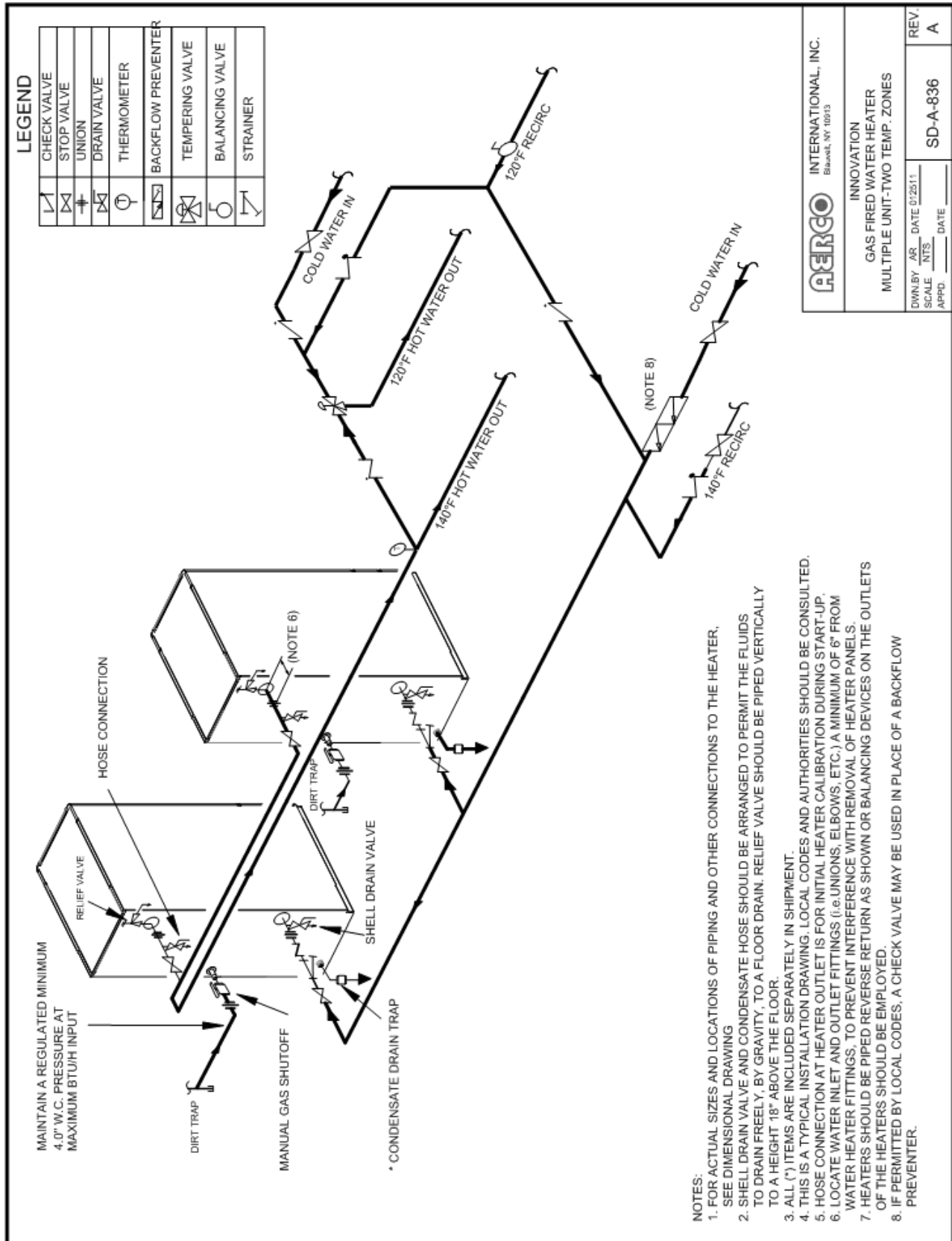

	INTERNATIONAL, INC. Blauvelt, NY 10913
	INNOVATION GAS FIRED WATER HEATER MULTIPLE UNIT-TWO TEMP. ZONES
DWN.BY: AR DATE: 07/20/11 SCALE: NTS APPD: _____ DATE: _____	REV: A SD-A-836



**PIPING DRAWINGS**

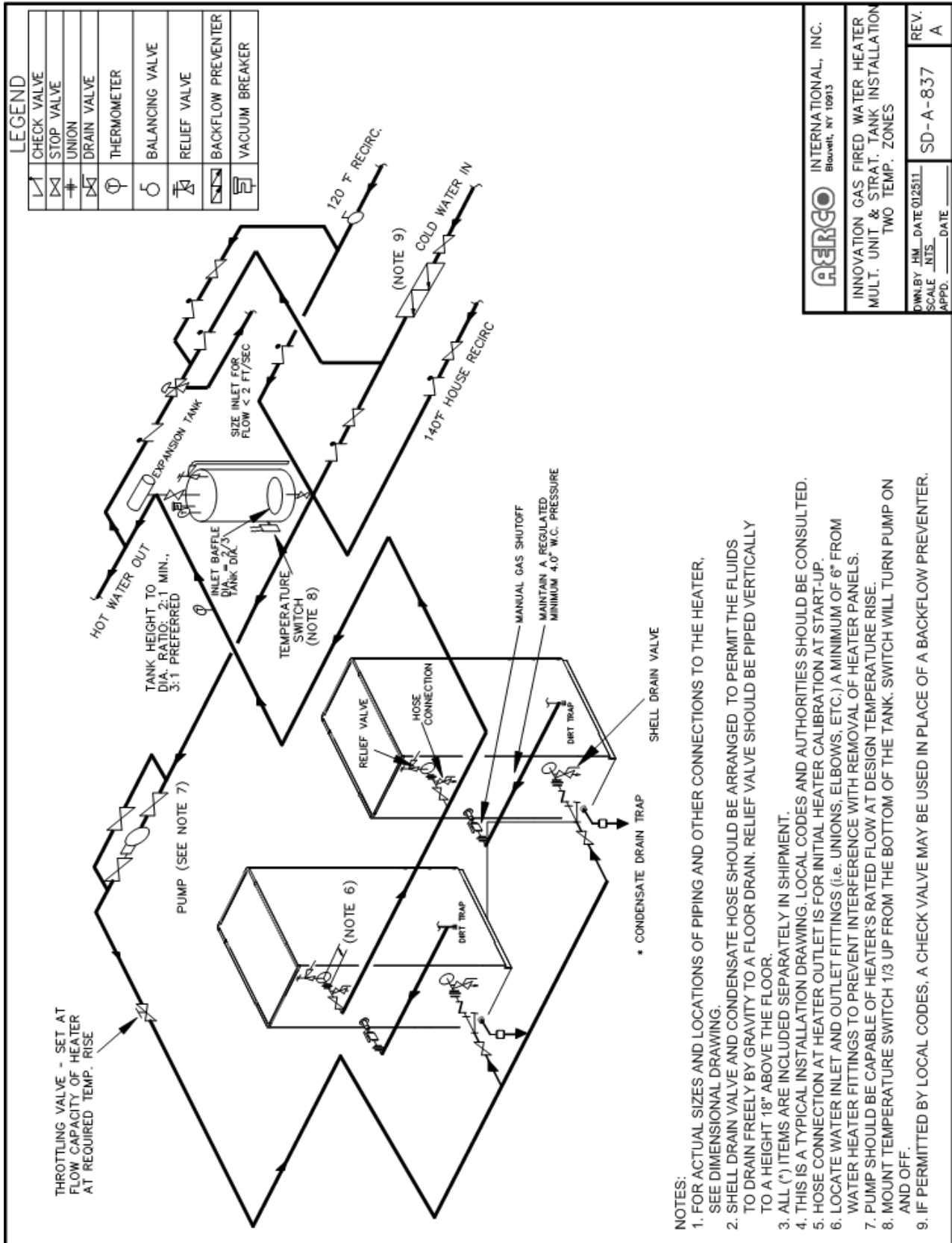

- NOTES:
1. FOR ACTUAL SIZES AND LOCATIONS OF PIPING AND OTHER CONNECTIONS TO THE HEATER, SEE DIMENSIONAL DRAWING.
  2. SHELL DRAIN VALVE AND CONDENSATE HOSE SHOULD BE ARRANGED TO PERMIT THE FLUIDS TO DRAIN FREELY BY GRAVITY TO A FLOOR DRAIN. RELIEF VALVE SHOULD BE PIPED VERTICALLY TO A HEIGHT 18" ABOVE THE FLOOR.
  3. ALL (\*) ITEMS ARE INCLUDED SEPARATELY IN SHIPMENT.
  4. THIS IS A TYPICAL INSTALLATION DRAWING. LOCAL CODES AND AUTHORITIES SHOULD BE CONSULTED.
  5. HOSE CONNECTION AT HEATER OUTLET IS FOR INITIAL HEATER CALIBRATION AT START-UP.
  6. LOCATE WATER INLET AND OUTLET FITTINGS (i.e. UNIONS, ELBOWS, ETC.) A MINIMUM OF 6" FROM WATER HEATER FITTINGS TO PREVENT INTERFERENCE WITH REMOVAL OF HEATER PANELS.
  7. PUMP SHOULD BE CAPABLE OF HEATER'S RATED FLOW AT DESIGN TEMPERATURE RISE.
  8. MOUNT TEMPERATURE SWITCH 1/3 UP FROM THE BOTTOM OF THE TANK. SWITCH WILL TURN PUMP ON AND OFF.
  9. IF PERMITTED BY LOCAL CODES, A CHECK VALVE MAY BE USED IN PLACE OF A BACKFLOW PREVENTER.

**PIPING DRAWINGS**

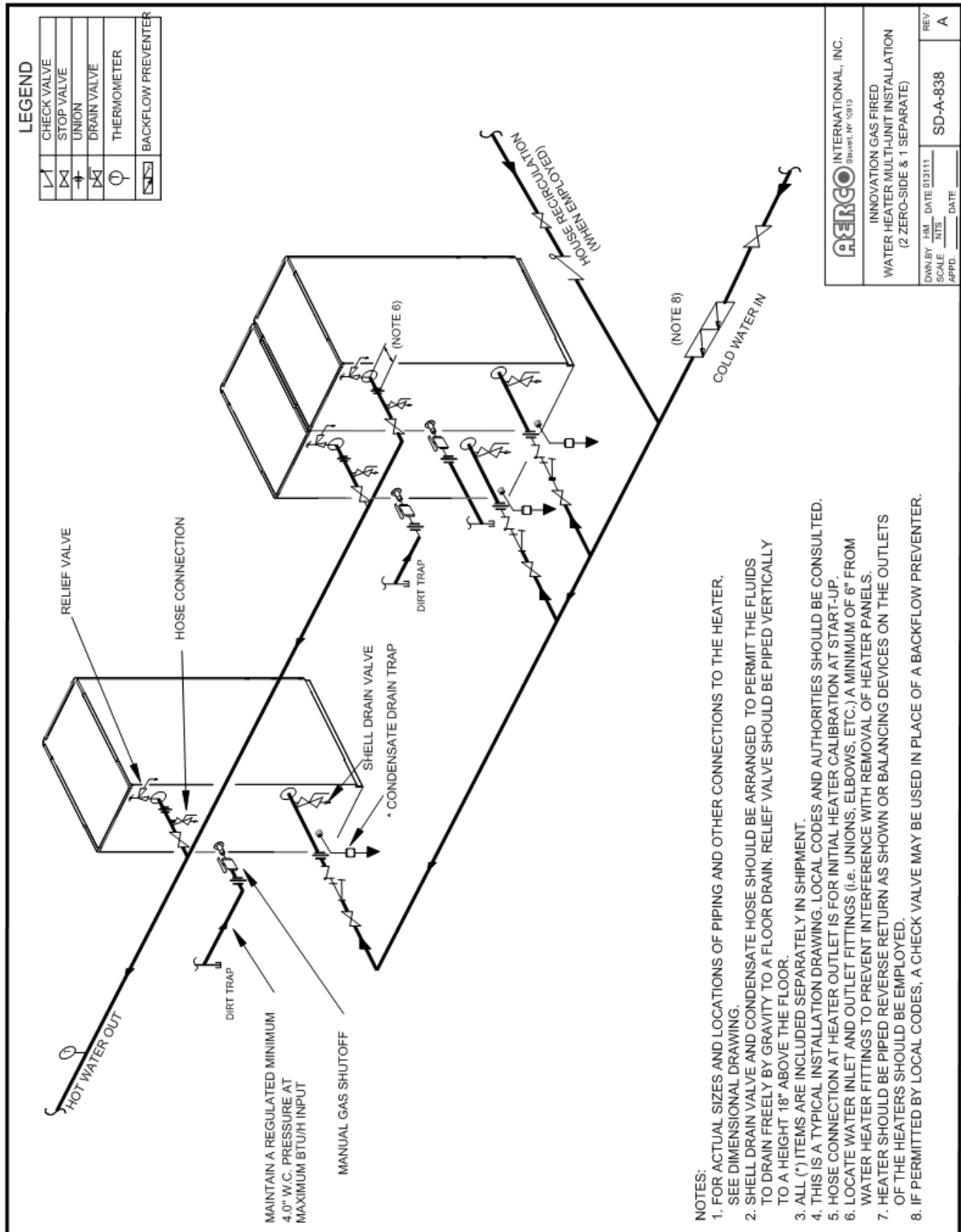

**PIPING DRAWINGS**

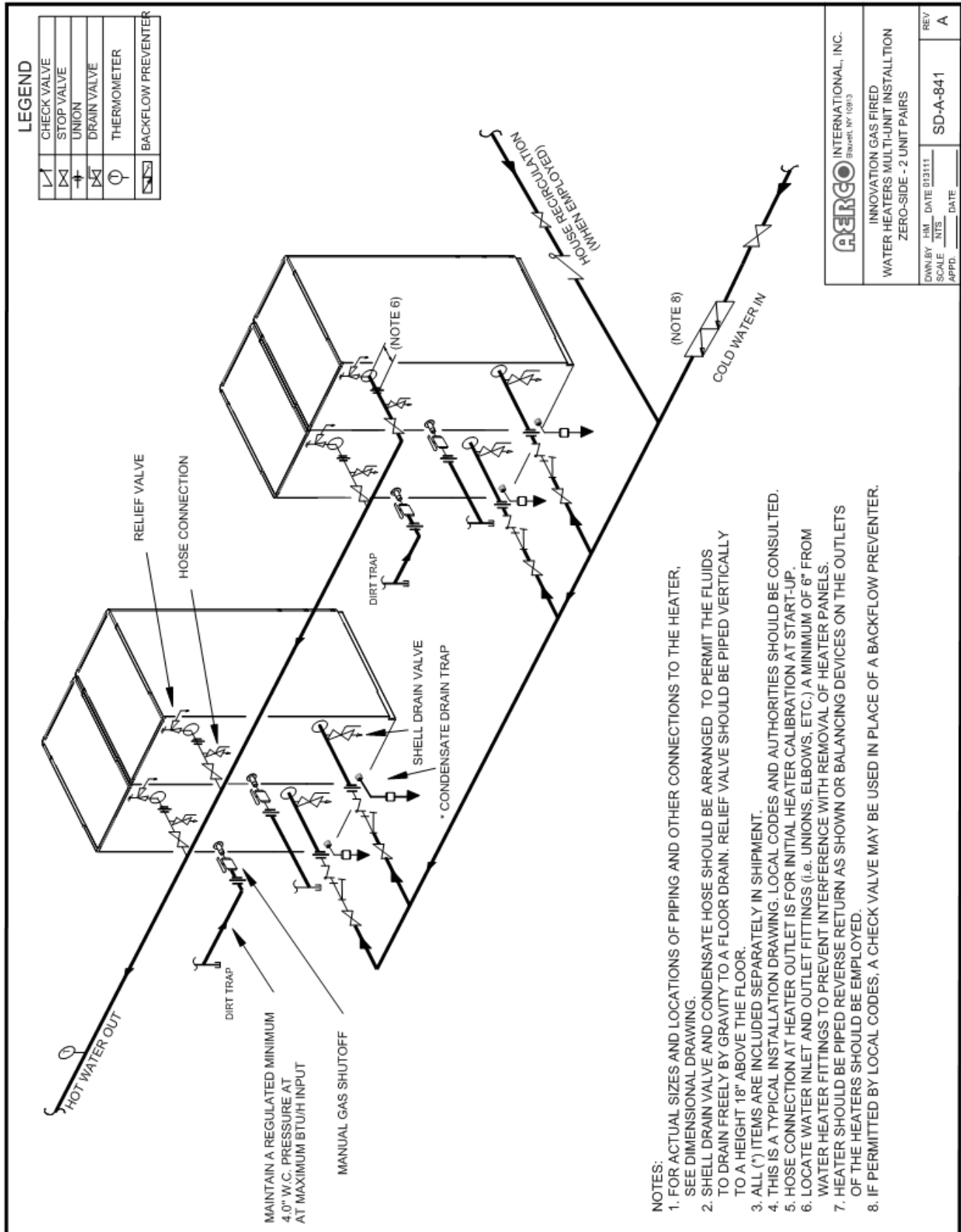

**PIPING DRAWINGS**

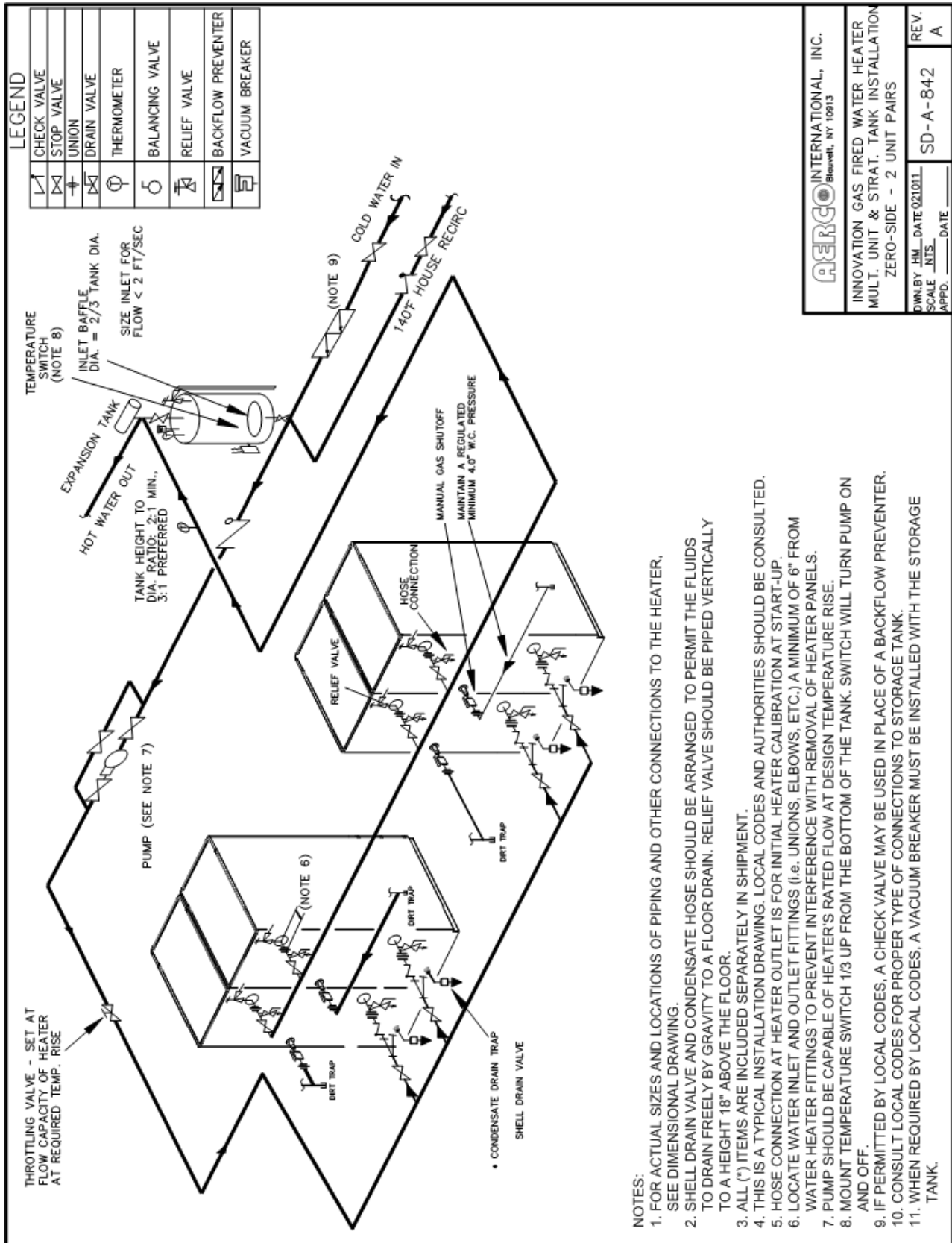

<b>AERCO INTERNATIONAL, INC.</b> <small>Blauvelt, NY 10913</small>	
INNOVATION GAS FIRED WATER HEATER MULT. UNIT & STRAT. TANK INSTALLATION ZERO-SIDE - 2 UNIT PAIRS	
DWN BY: HM	DATE: 02/10/11
SCALE: INTS.	DATE:
APPD: _____	DATE:
REV. _____	SD-A-842
_____	A

- NOTES:**
- FOR ACTUAL SIZES AND LOCATIONS OF PIPING AND OTHER CONNECTIONS TO THE HEATER, SEE DIMENSIONAL DRAWING.
  - SHELL DRAIN VALVE AND CONDENSATE HOSE SHOULD BE ARRANGED TO PERMIT THE FLUIDS TO DRAIN FREELY BY GRAVITY TO A FLOOR DRAIN. RELIEF VALVE SHOULD BE PIPED VERTICALLY TO A HEIGHT 18" ABOVE THE FLOOR.
  - ALL (\*) ITEMS ARE INCLUDED SEPARATELY IN SHIPMENT.
  - HOSE CONNECTION AT HEATER OUTLET IS FOR INITIAL HEATER CALIBRATION AT START-UP.
  - LOCATE WATER INLET AND OUTLET FITTINGS (i.e. UNIONS, ELBOWS, ETC.) A MINIMUM OF 6" FROM WATER HEATER FITTINGS TO PREVENT INTERFERENCE WITH REMOVAL OF HEATER PANELS.
  - PUMP SHOULD BE CAPABLE OF HEATER'S RATED FLOW AT DESIGN TEMPERATURE RISE.
  - MOUNT TEMPERATURE SWITCH 1/3 UP FROM THE BOTTOM OF THE TANK. SWITCH WILL TURN PUMP ON AND OFF.
  - IF PERMITTED BY LOCAL CODES, A CHECK VALVE MAY BE USED IN PLACE OF A BACKFLOW PREVENTER.
  - CONSULT LOCAL CODES FOR PROPER TYPE OF CONNECTIONS TO STORAGE TANK.
  - WHEN REQUIRED BY LOCAL CODES, A VACUUM BREAKER MUST BE INSTALLED WITH THE STORAGE TANK.



**PIPING DRAWINGS**

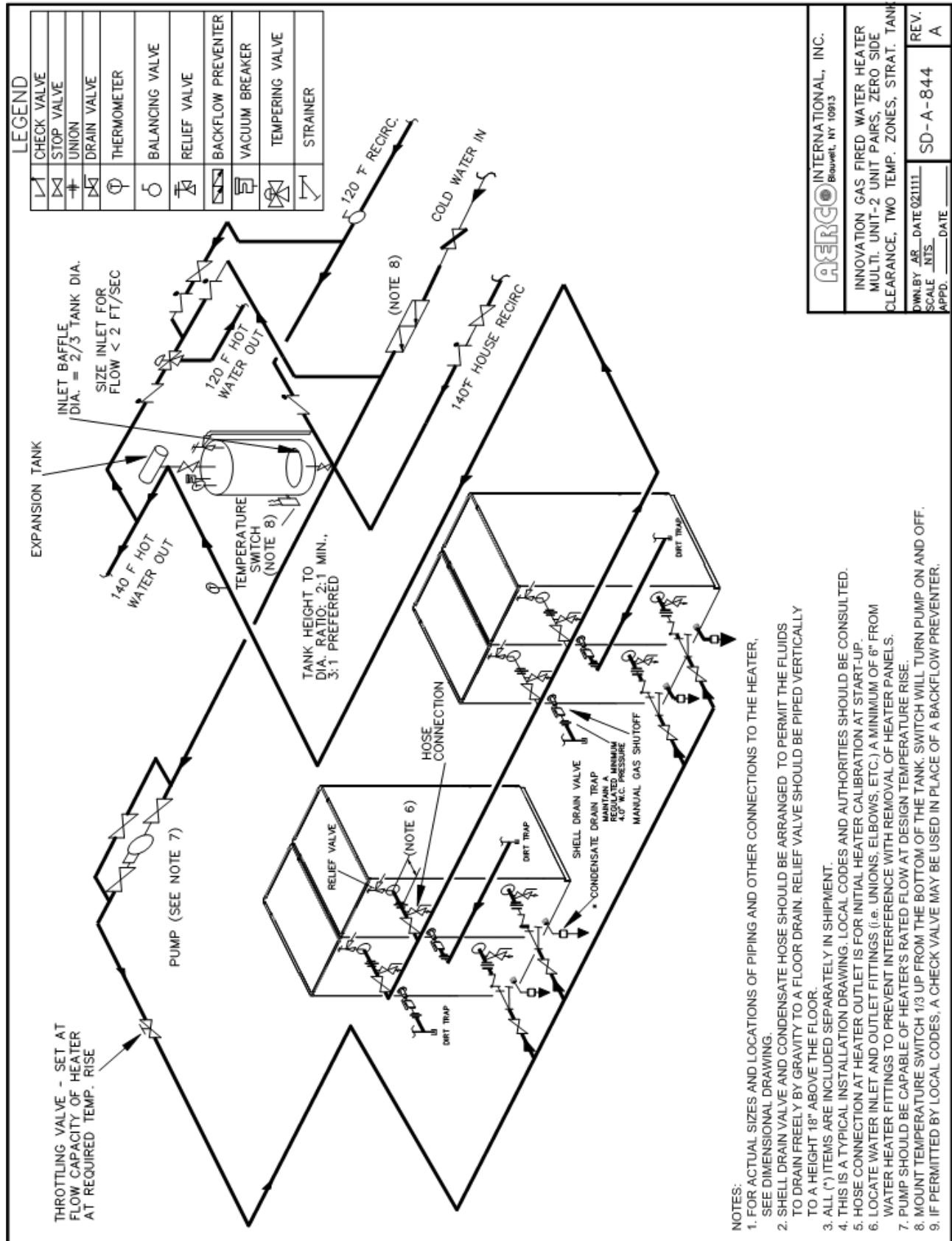

**PIPING DRAWINGS**

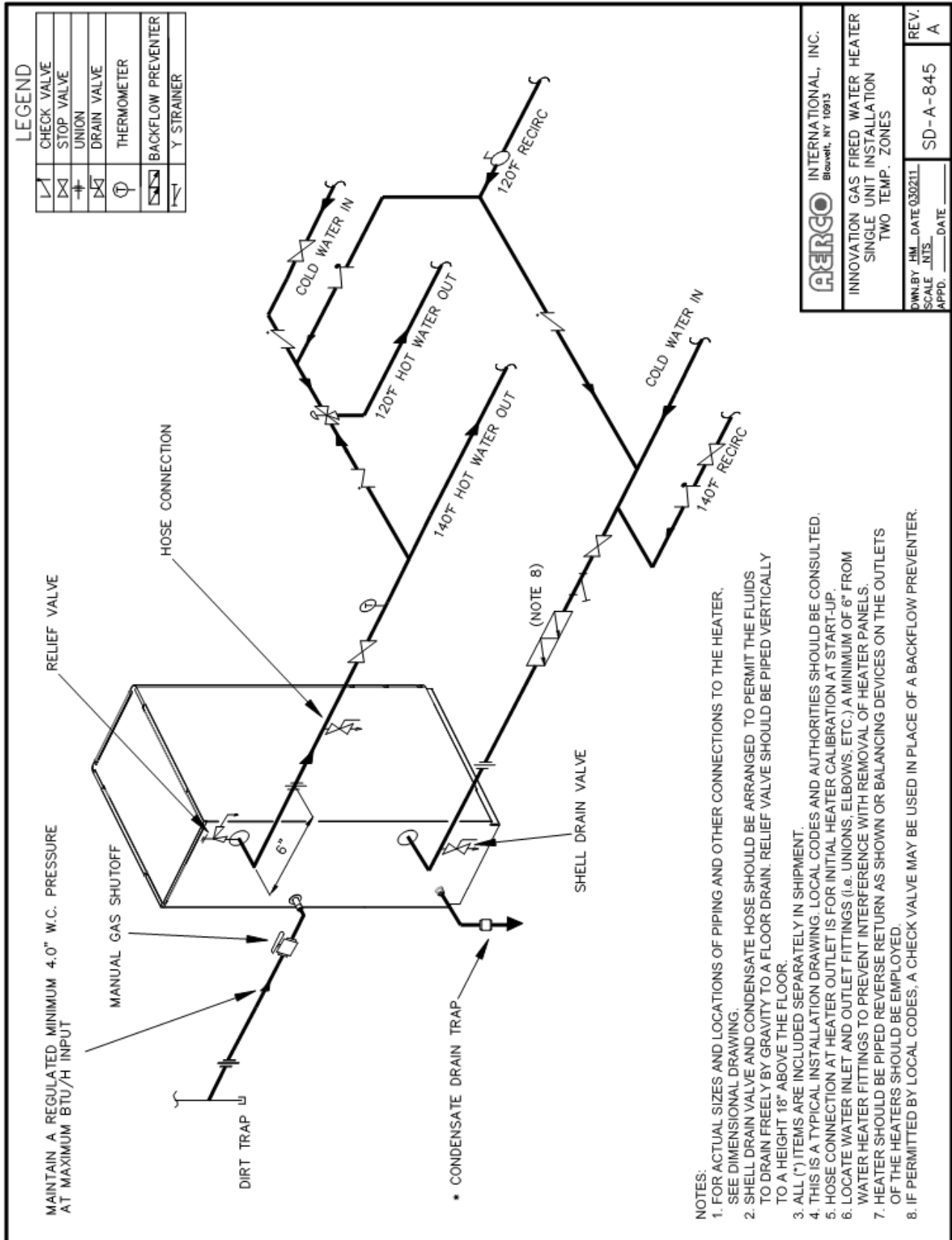





**PIPING DRAWINGS**

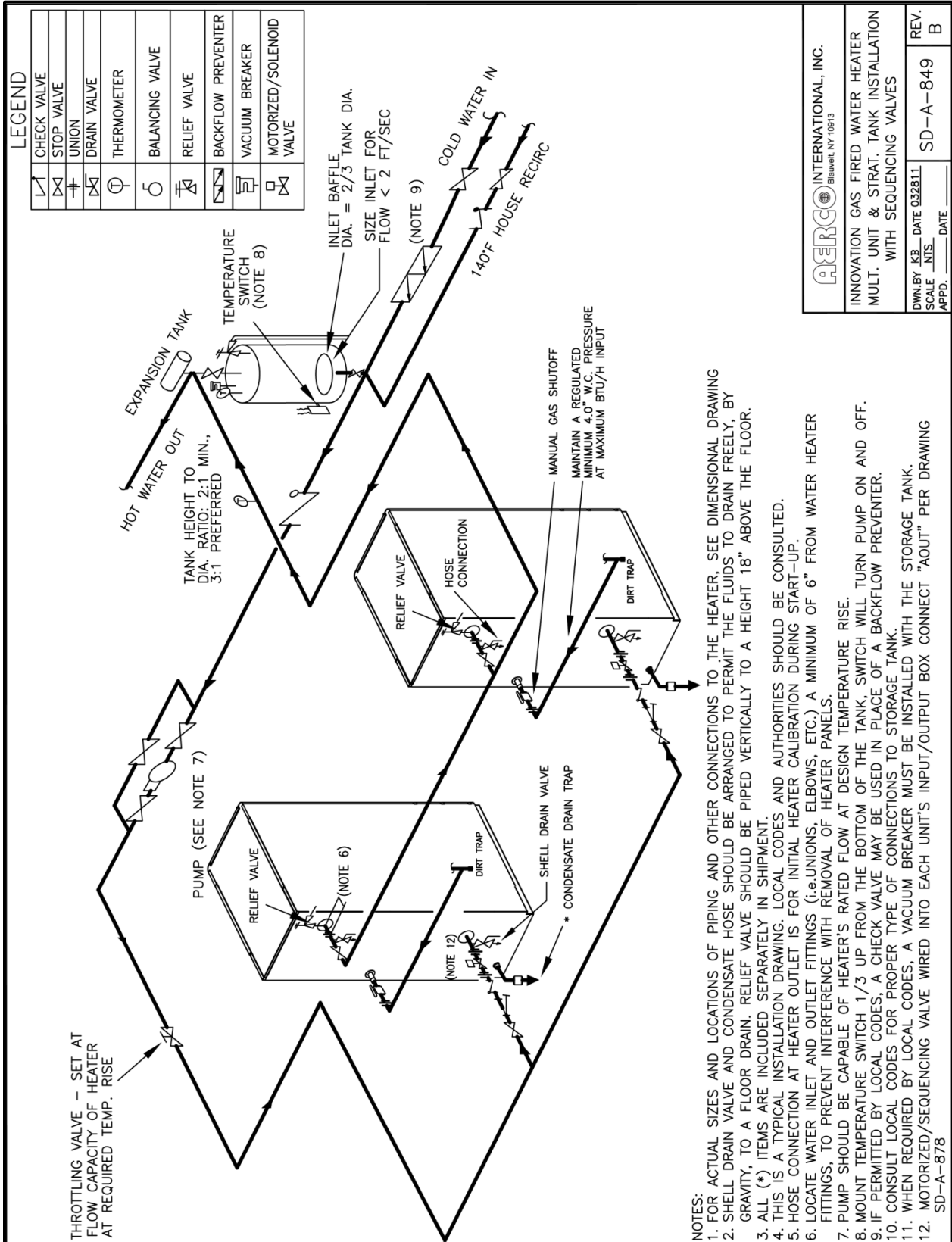

**AERCO** INTERNATIONAL, INC.  
Blauvelt, NY 10913

INNOVATION GAS FIRED WATER HEATER  
 MULT. UNIT & STRAT. TANK INSTALLATION  
 WITH SEQUENCING VALVES

DWN.BY: KB DATE 032811  
 SCALE: NTS  
 APPD. \_\_\_\_\_ DATE \_\_\_\_\_  
 SD-A-849  
 REV. B

- NOTES:**
1. FOR ACTUAL SIZES AND LOCATIONS OF PIPING AND OTHER CONNECTIONS TO THE HEATER, SEE DIMENSIONAL DRAWING
  2. SHELL DRAIN VALVE AND CONDENSATE HOSE SHOULD BE ARRANGED TO PERMIT THE FLUIDS TO DRAIN FREELY, BY GRAVITY, TO A FLOOR DRAIN. RELIEF VALVE SHOULD BE PIPED VERTICALLY TO A HEIGHT 18" ABOVE THE FLOOR.
  3. ALL (\*) ITEMS ARE INCLUDED SEPARATELY IN SHIPMENT.
  4. THIS IS A TYPICAL INSTALLATION DRAWING. LOCAL CODES AND AUTHORITIES SHOULD BE CONSULTED.
  5. HOSE CONNECTION AT HEATER OUTLET IS FOR INITIAL HEATER CALIBRATION DURING START-UP.
  6. LOCATE WATER INLET AND OUTLET FITTINGS (i.e. UNIONS, ELBOWS, ETC.) A MINIMUM OF 6" FROM WATER HEATER FITTINGS, TO PREVENT INTERFERENCE WITH REMOVAL OF HEATER PANELS.
  7. PUMP SHOULD BE CAPABLE OF HEATER'S RATED FLOW AT DESIGN TEMPERATURE RISE.
  8. MOUNT TEMPERATURE SWITCH 1/3 UP FROM THE BOTTOM OF THE TANK. SWITCH WILL TURN PUMP ON AND OFF.
  9. IF PERMITTED BY LOCAL CODES, A CHECK VALVE MAY BE USED IN PLACE OF A BACKFLOW PREVENTER.
  10. CONSULT LOCAL CODES FOR PROPER TYPE OF CONNECTIONS TO STORAGE TANK.
  11. WHEN REQUIRED BY LOCAL CODES, A VACUUM BREAKER MUST BE INSTALLED WITH THE STORAGE TANK.
  12. MOTORIZED/SEQUENCING VALVE WIRED INTO EACH UNIT'S INPUT/OUTPUT BOX CONNECT "AOUT" PER DRAWING SD-A-878

PIPING DRAWING

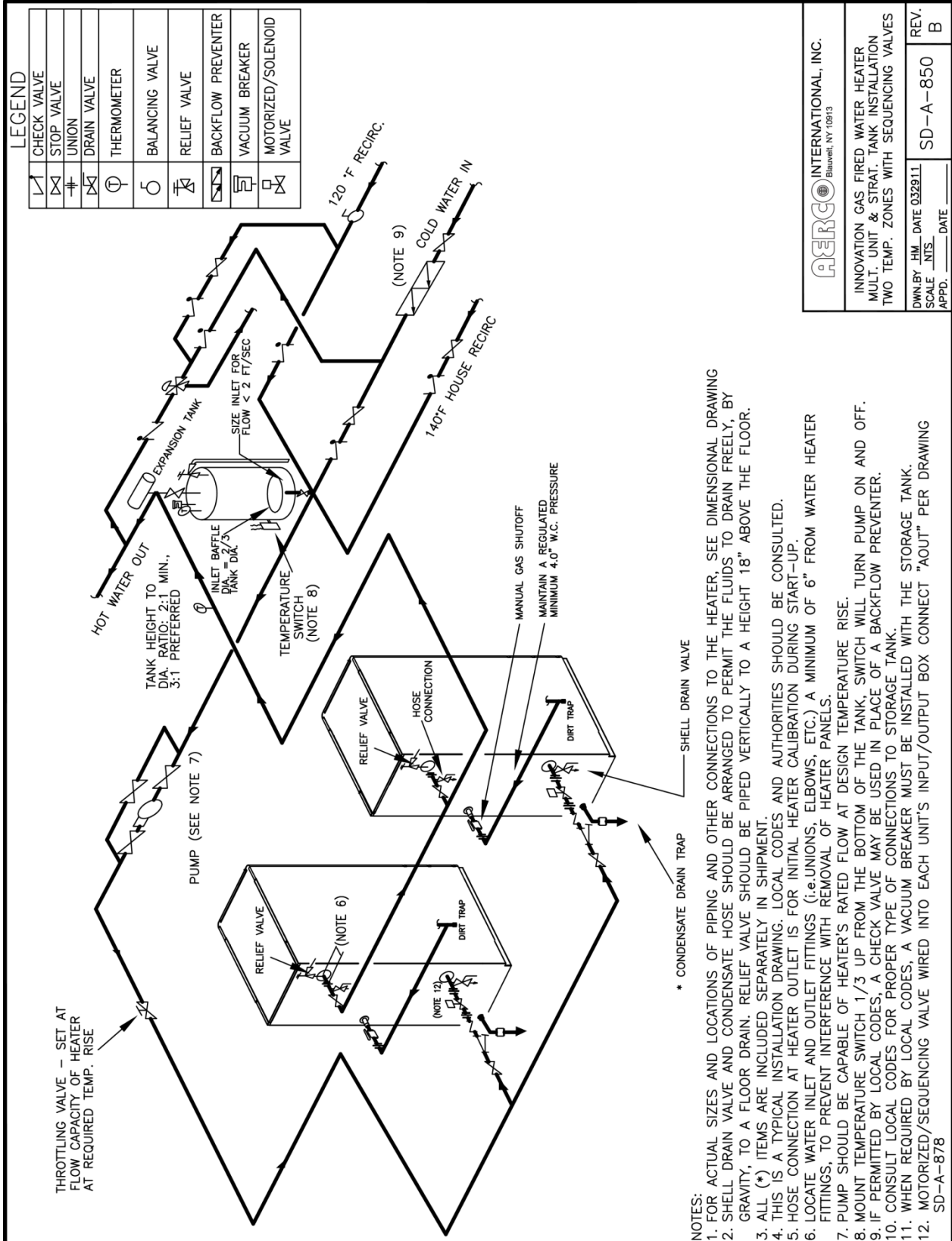

THROTTLING VALVE - SET AT FLOW CAPACITY OF HEATER AT REQUIRED TEMP. RISE

TANK HEIGHT TO DIA. RATIO: 2:1 MIN., 3:1 PREFERRED

PUMP (SEE NOTE 7)

TEMPERATURE SWITCH (NOTE 8)

INLET BAFFLE DIA. = 2/3 TANK DIA.

SIZE INLET FOR FLOW < 2 FT/SEC

(NOTE 9)

140°F HOUSE RECIRC

120°F RECIRC.

MANUAL GAS SHUTOFF MAINTAIN A REGULATED MINIMUM 4.0" W.C. PRESSURE

RELIEF VALVE

HOSE CONNECTION

DIRT TRAP

SHELL DRAIN VALVE

\* CONDENSATE DRAIN TRAP

(NOTE 12)

RELIEF VALVE (NOTE 6)

DIRT TRAP

(NOTE 10)

DIRT TRAP

RELIEF VALVE

DIRT TRAP

RELIEF VALVE

DIRT TRAP

- NOTES:
- FOR ACTUAL SIZES AND LOCATIONS OF PIPING AND OTHER CONNECTIONS TO THE HEATER, SEE DIMENSIONAL DRAWING
  - SHELL DRAIN VALVE AND CONDENSATE HOSE SHOULD BE ARRANGED TO PERMIT THE FLUIDS TO DRAIN FREELY, BY GRAVITY, TO A FLOOR DRAIN. RELIEF VALVE SHOULD BE PIPED VERTICALLY TO A HEIGHT 18" ABOVE THE FLOOR.
  - ALL (\*) ITEMS ARE INCLUDED SEPARATELY IN SHIPMENT.
  - THIS IS A TYPICAL INSTALLATION DRAWING. LOCAL CODES AND AUTHORITIES SHOULD BE CONSULTED.
  - HOSE CONNECTION AT HEATER OUTLET IS FOR INITIAL HEATER CALIBRATION DURING START-UP.
  - LOCATE WATER INLET AND OUTLET FITTINGS (i.e. UNIONS, ELBOWS, ETC.) A MINIMUM OF 6" FROM WATER HEATER FITTINGS, TO PREVENT INTERFERENCE WITH REMOVAL OF HEATER PANELS.
  - PUMP SHOULD BE CAPABLE OF HEATER'S RATED FLOW AT DESIGN TEMPERATURE RISE.
  - MOUNT TEMPERATURE SWITCH 1/3 UP FROM THE BOTTOM OF THE TANK. SWITCH WILL TURN PUMP ON AND OFF.
  - IF PERMITTED BY LOCAL CODES, A CHECK VALVE MAY BE USED IN PLACE OF A BACKFLOW PREVENTER.
  - CONSULT LOCAL CODES FOR PROPER TYPE OF CONNECTIONS TO STORAGE TANK.
  - WHEN REQUIRED BY LOCAL CODES, A VACUUM BREAKER MUST BE INSTALLED WITH THE STORAGE TANK.
  - MOTORIZED/SEQUENCING VALVE WIRED INTO EACH UNIT'S INPUT/OUTPUT BOX CONNECT "AOUT" PER DRAWING SD-A-878

PIPING DRAWINGS

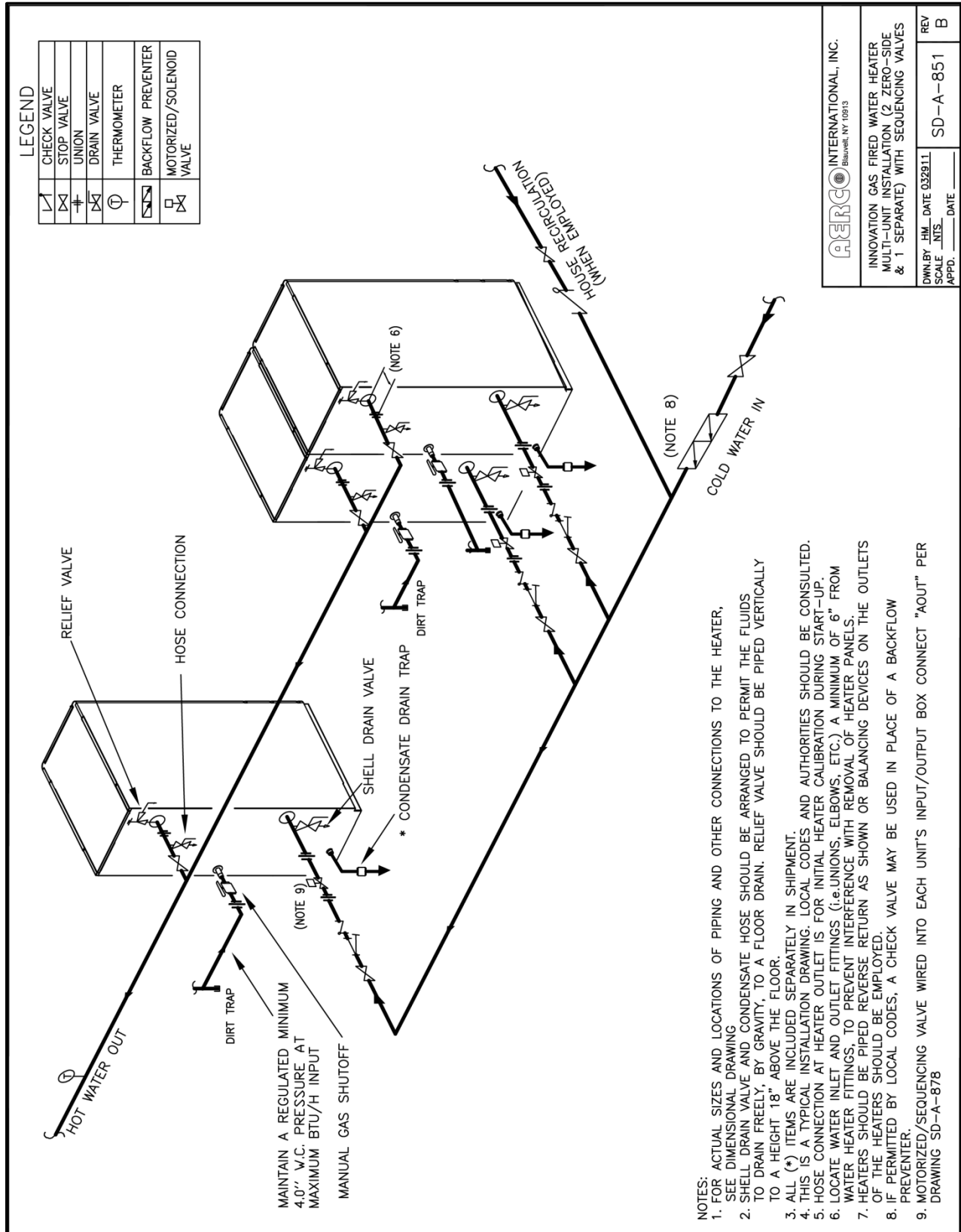

LEGEND

	CHECK VALVE
	STOP VALVE
	UNION
	DRAIN VALVE
	THERMOMETER
	BACKFLOW PREVENTER
	MOTORIZED/SOLENOID VALVE

 INTERNATIONAL, INC. <small>Blauvelt, NY 10913</small>	
INNOVATION GAS FIRED WATER HEATER MULTI-UNIT INSTALLATION (2 ZERO-SIDE & 1 SEPARATE) WITH SEQUENCING VALVES	
DWN.BY	REV
HM.	NTS.
DATE	DATE
SCALE	SD-A-851
APPD.	B

- NOTES:
- FOR ACTUAL SIZES AND LOCATIONS OF PIPING AND OTHER CONNECTIONS TO THE HEATER, SEE DIMENSIONAL DRAWING
  - SHELL DRAIN VALVE AND CONDENSATE HOSE SHOULD BE ARRANGED TO PERMIT THE FLUIDS TO DRAIN FREELY, BY GRAVITY, TO A FLOOR DRAIN. RELIEF VALVE SHOULD BE PIPED VERTICALLY TO A HEIGHT 18" ABOVE THE FLOOR.
  - ALL (\*) ITEMS ARE INCLUDED SEPARATELY IN SHIPMENT.
  - THIS IS A TYPICAL INSTALLATION DRAWING. LOCAL CODES AND AUTHORITIES SHOULD BE CONSULTED.
  - HOSE CONNECTION AT HEATER OUTLET IS FOR INITIAL HEATER CALIBRATION DURING START-UP.
  - LOCATE WATER INLET AND OUTLET FITTINGS (i.e. UNIONS, ELBOWS, ETC.) A MINIMUM OF 6" FROM WATER HEATER FITTINGS, TO PREVENT INTERFERENCE WITH REMOVAL OF HEATER PANELS.
  - HEATERS SHOULD BE PIPED REVERSE RETURN AS SHOWN OR BALANCING DEVICES ON THE OUTLETS OF THE HEATERS SHOULD BE EMPLOYED.
  - IF PERMITTED BY LOCAL CODES, A CHECK VALVE MAY BE USED IN PLACE OF A BACKFLOW PREVENTER.
  - MOTORIZED/SEQUENCING VALVE WIRED INTO EACH UNIT'S INPUT/OUTPUT BOX CONNECT "AOUT" PER DRAWING SD-A-878

PIPING DRAWINGS

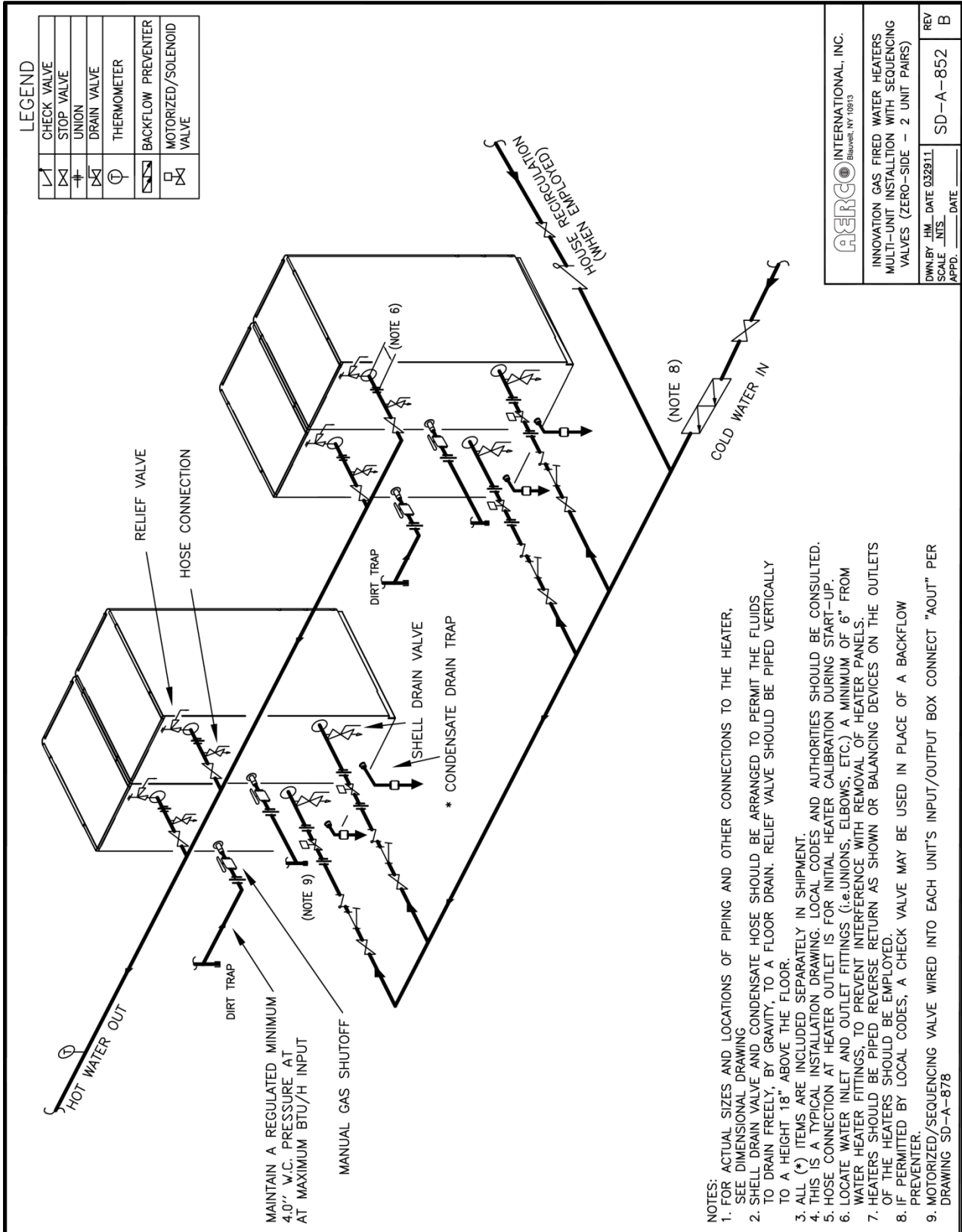

PIPING DRAWINGS

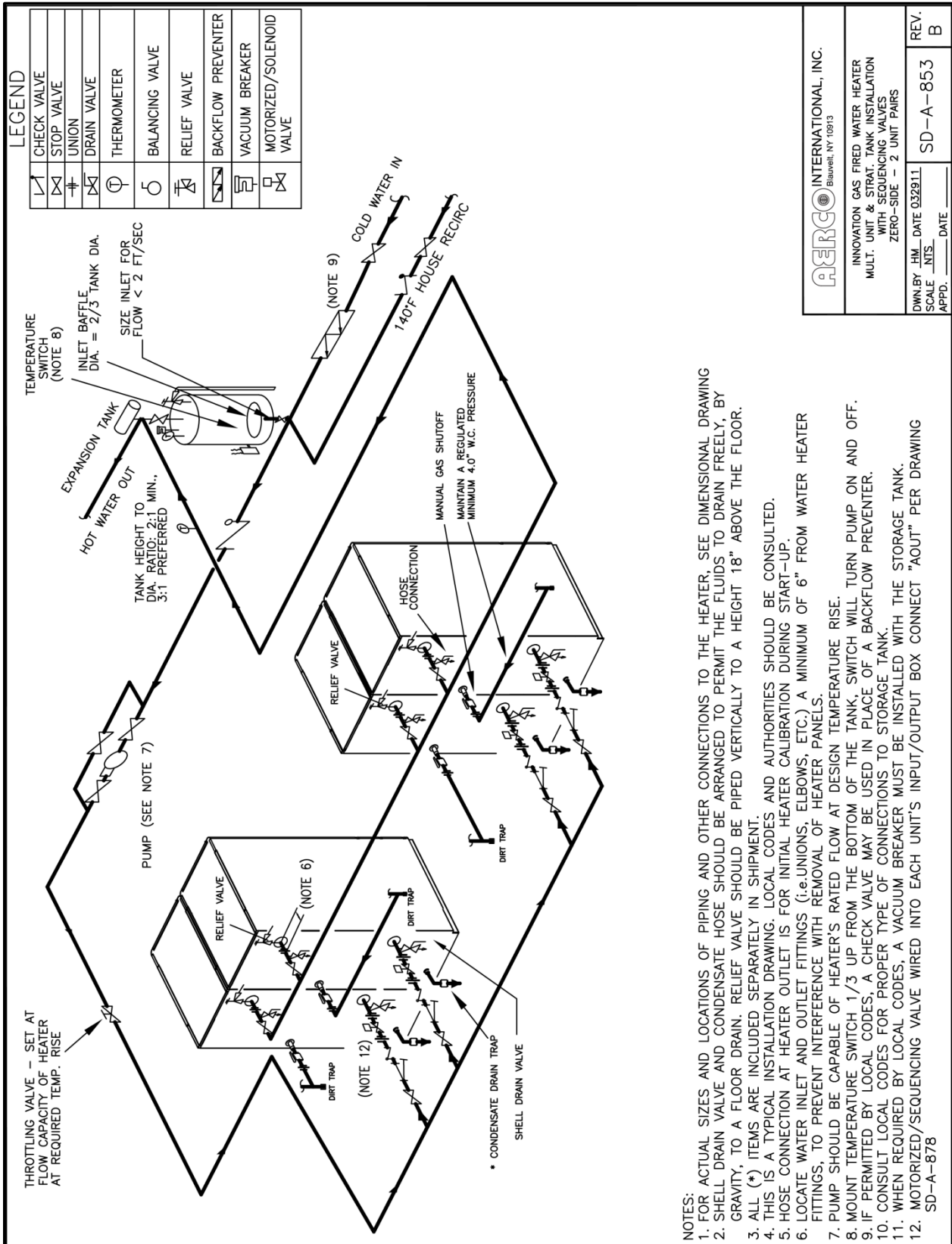

- NOTES:
1. FOR ACTUAL SIZES AND LOCATIONS OF PIPING AND OTHER CONNECTIONS TO THE HEATER, SEE DIMENSIONAL DRAWING.
  2. SHELL DRAIN VALVE AND CONDENSATE HOSE SHOULD BE ARRANGED TO PERMIT THE FLUIDS TO DRAIN FREELY, BY GRAVITY, TO A FLOOR DRAIN. RELIEF VALVE SHOULD BE PIPED VERTICALLY TO A HEIGHT 18" ABOVE THE FLOOR.
  3. ALL (\*) ITEMS ARE INCLUDED SEPARATELY IN SHIPMENT.
  4. THIS IS A TYPICAL INSTALLATION DRAWING. LOCAL CODES AND AUTHORITIES SHOULD BE CONSULTED.
  5. HOSE CONNECTION AT HEATER OUTLET IS FOR INITIAL HEATER CALIBRATION DURING START-UP.
  6. LOCATE WATER INLET AND OUTLET FITTINGS (i.e. UNIONS, ELBOWS, ETC.) A MINIMUM OF 6" FROM WATER HEATER FITTINGS, TO PREVENT INTERFERENCE WITH REMOVAL OF HEATER PANELS.
  7. PUMP SHOULD BE CAPABLE OF HEATER'S RATED FLOW AT DESIGN TEMPERATURE RISE.
  8. MOUNT TEMPERATURE SWITCH 1/3 UP FROM THE BOTTOM OF THE TANK. SWITCH WILL TURN PUMP ON AND OFF.
  9. IF PERMITTED BY LOCAL CODES, A CHECK VALVE MAY BE USED IN PLACE OF A BACKFLOW PREVENTER.
  10. CONSULT LOCAL CODES FOR PROPER TYPE OF CONNECTIONS TO STORAGE TANK.
  11. WHEN REQUIRED BY LOCAL CODES, A VACUUM BREAKER MUST BE INSTALLED WITH THE STORAGE TANK.
  12. MOTORIZED/SEQUENCING VALVE WIRED INTO EACH UNIT'S INPUT/OUTPUT BOX CONNECT "AOUT" PER DRAWING SD-A-878



PIPING DRAWINGS

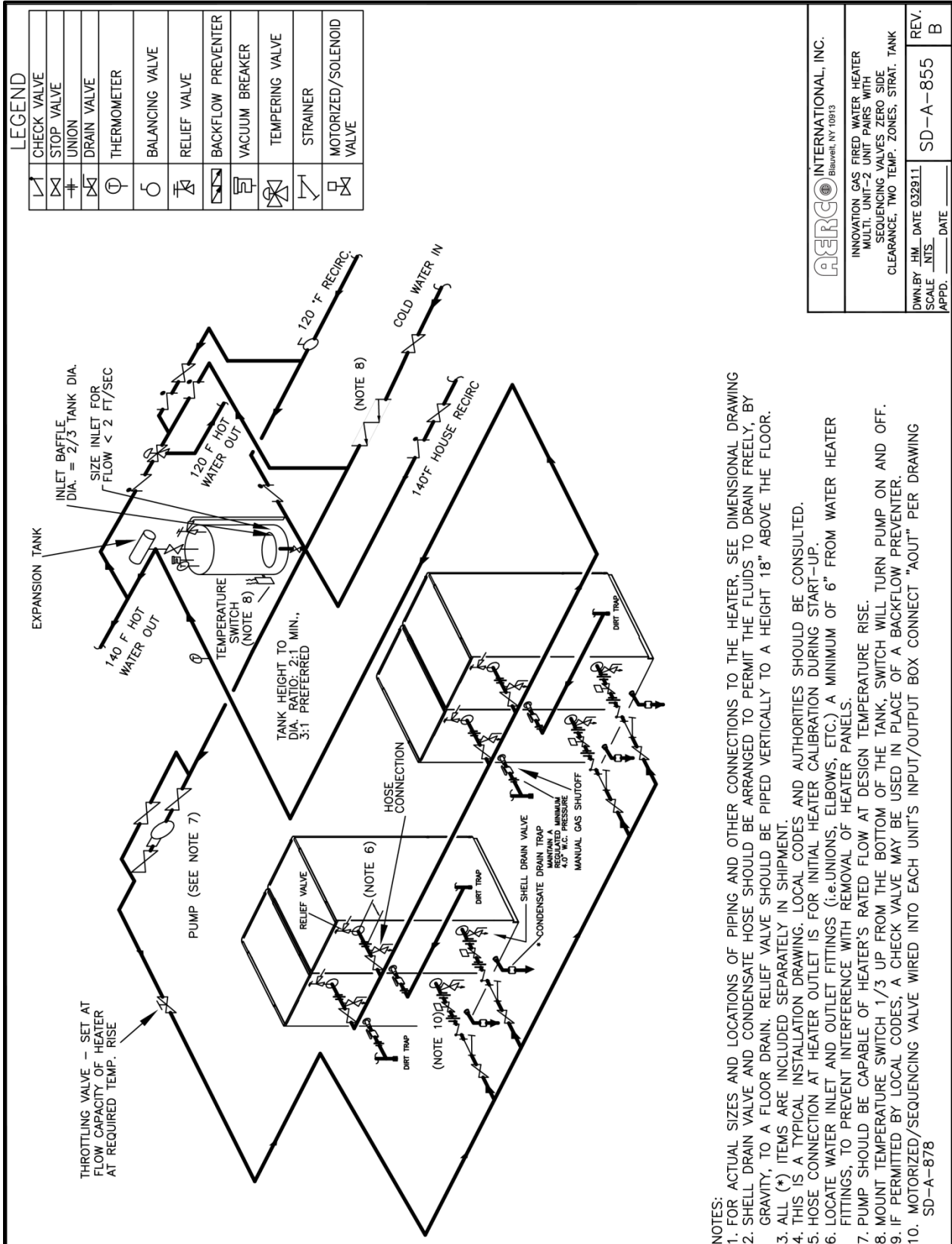

<b>AERCO</b> INTERNATIONAL, INC. <small>Blauvelt, NY 10913</small>	
INNOVATION GAS FIRED WATER HEATER MULT. UNIT-2 UNIT PAIRS WITH SEQUENCING VALVES ZERO SIDE CLEARANCE, TWO TEMP. ZONES, STRAT. TANK	
DWN. BY: HM DATE 032911 SCALE: NTS APPD. DATE	SD-A-855 REV. B

- NOTES:
1. FOR ACTUAL SIZES AND LOCATIONS OF PIPING AND OTHER CONNECTIONS TO THE HEATER, SEE DIMENSIONAL DRAWING
  2. SHELL DRAIN VALVE AND CONDENSATE HOSE SHOULD BE ARRANGED TO PERMIT THE FLUIDS TO DRAIN FREELY, BY GRAVITY, TO A FLOOR DRAIN. RELIEF VALVE SHOULD BE PIPED VERTICALLY TO A HEIGHT 18" ABOVE THE FLOOR.
  3. ALL (\*) ITEMS ARE INCLUDED SEPARATELY IN SHIPMENT.
  4. THIS IS A TYPICAL INSTALLATION DRAWING. LOCAL CODES AND AUTHORITIES SHOULD BE CONSULTED.
  5. HOSE CONNECTION AT HEATER OUTLET IS FOR INITIAL HEATER CALIBRATION DURING START-UP.
  6. LOCATE WATER INLET AND OUTLET FITTINGS (i.e. UNIONS, ELBOWS, ETC.) A MINIMUM OF 6" FROM WATER HEATER FITTINGS, TO PREVENT INTERFERENCE WITH REMOVAL OF HEATER PANELS.
  7. PUMP SHOULD BE CAPABLE OF HEATER'S RATED FLOW AT DESIGN TEMPERATURE RISE.
  8. MOUNT TEMPERATURE SWITCH 1/3 UP FROM THE BOTTOM OF THE TANK, SWITCH WILL TURN PUMP ON AND OFF.
  9. IF PERMITTED BY LOCAL CODES, A CHECK VALVE MAY BE USED IN PLACE OF A BACKFLOW PREVENTER.
  10. MOTORIZED/SEQUENCING VALVE WIRED INTO EACH UNIT'S INPUT/OUTPUT BOX CONNECT "AOUT" PER DRAWING SD-A-878

PIPING DRAWINGS

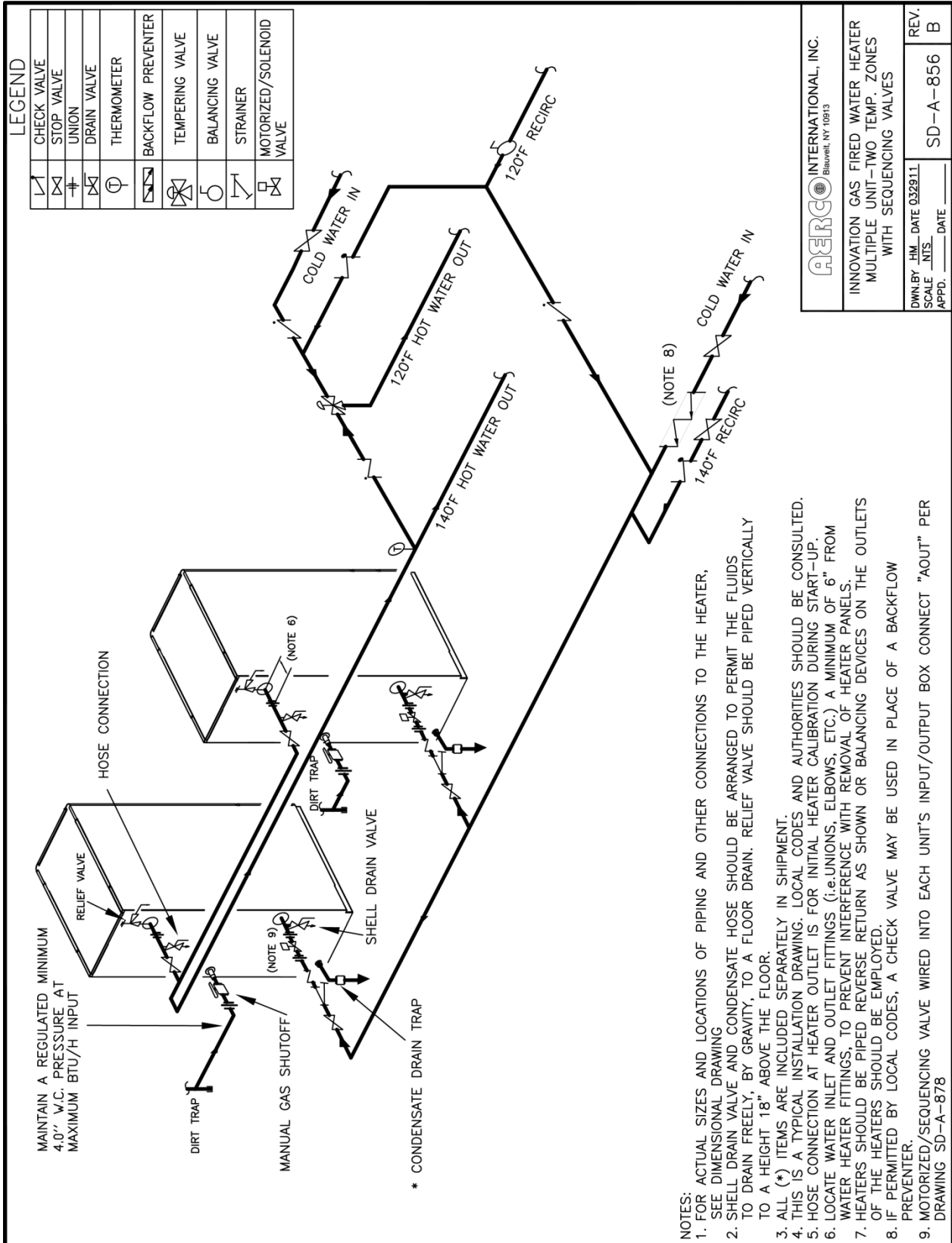



**APPENDIX G: C-MORE CONTROL PANEL VIEWS**

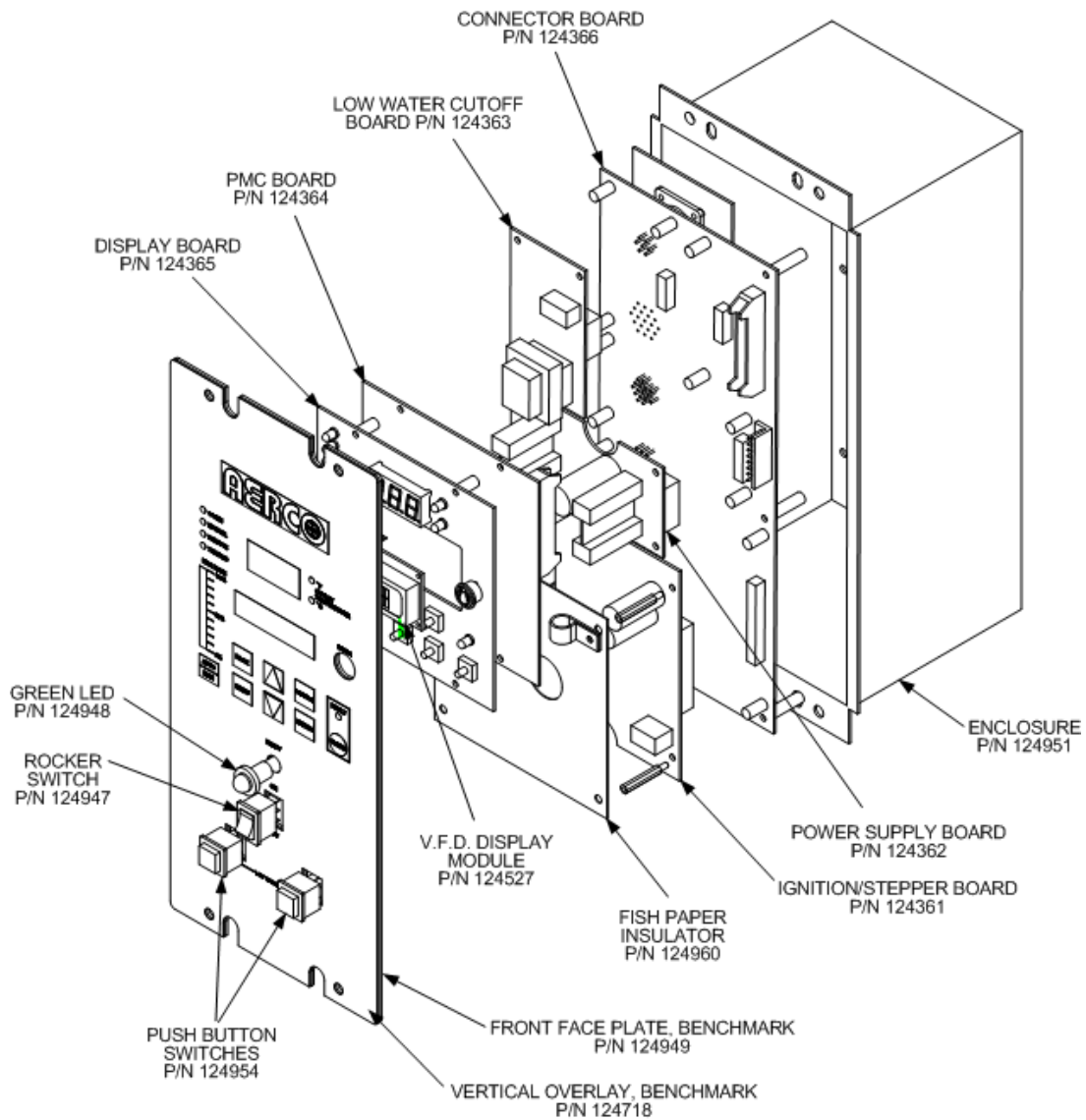

**C-MORE CONTROL PANEL EXPLODED VIEW**

### C-MORE CONTROL PANEL VIEWS

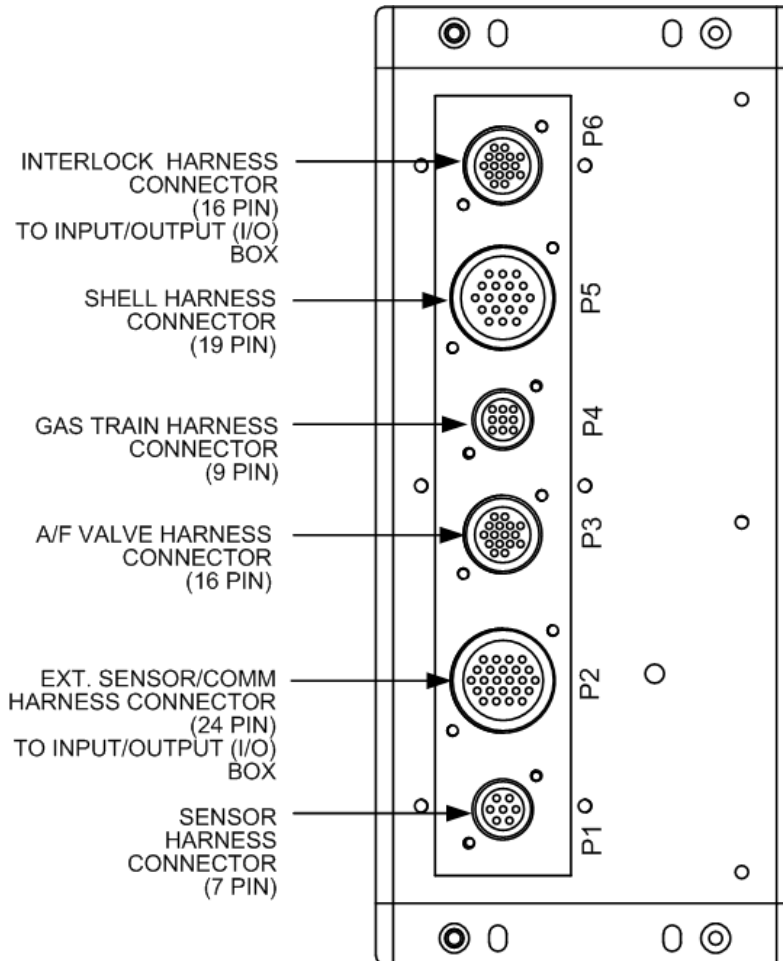

**C-MORE CONTROL PANEL REAR VIEW**

APPENDIX H: C-MORE WIRING DIAGRAMS

CONTROL BOX CONNECTIONS

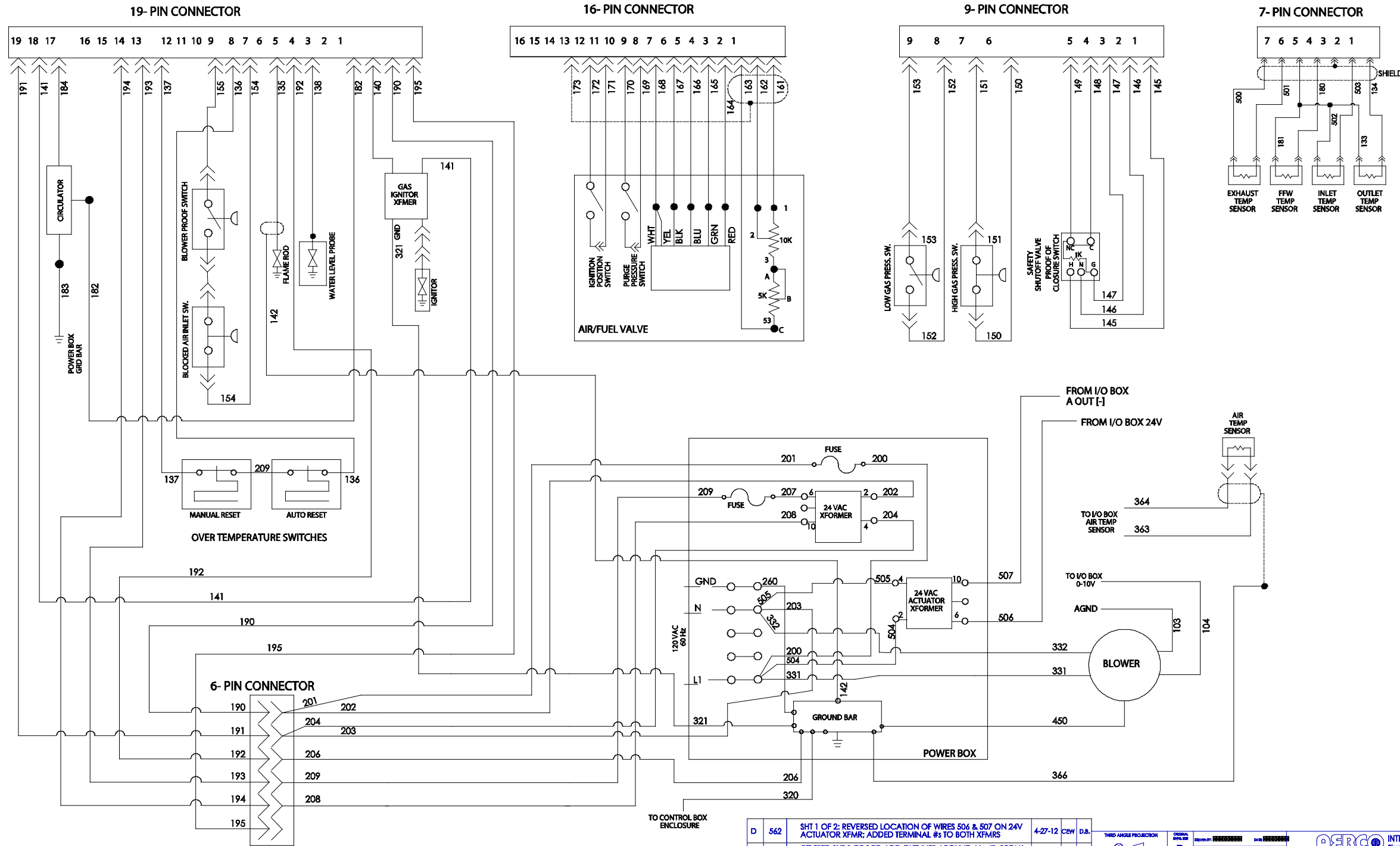

REV	BY	DATE	DESCRIPTION	DATE	BY	CHKD
D	562	4-27-12	SHT 1 OF 2: REVERSED LOCATION OF WIRES 506 & 507 ON 24V ACTUATOR XFMR; ADDED TERMINAL #3 TO BOTH XFMRs	CEW	D.B.	
C	529	4-23-12	REVISED SHT 2 OF 2 TO ADD OUTLINES AROUND J6 - J9; BREAK CONTACT BETWEEN PIN 1&2 ON J7 SHT 1 OF 2	CEW		
B	529	4-18-12	REVISED SHT 2 OF 2 TO REARRANGE 24-PIN # ASSIGNMENTS	CEW		
A	529	4-2-12	RELEASED FOR PRODUCTION VALIDATION	CEW		
REV	ECO		REVISIONS	DATE	BY	CHKD

THIRD ANGLE PROJECTION	ORIGINAL	DATE	DATE
	D		
AERCO INTERNATIONAL INC. Blauvelt, NY 10913			
TITLE WIRING SCHEMATIC 120 VAC, 60 Hz INNOVATION w/SEQ. VALVE @ 24 VAC			
DATE SPEC.	DWG. NO.	REV	
	88039	D	
		SHEET 1 OF 2	

This Page Is Intentionally Blank

CONTROL BOX CONNECTIONS

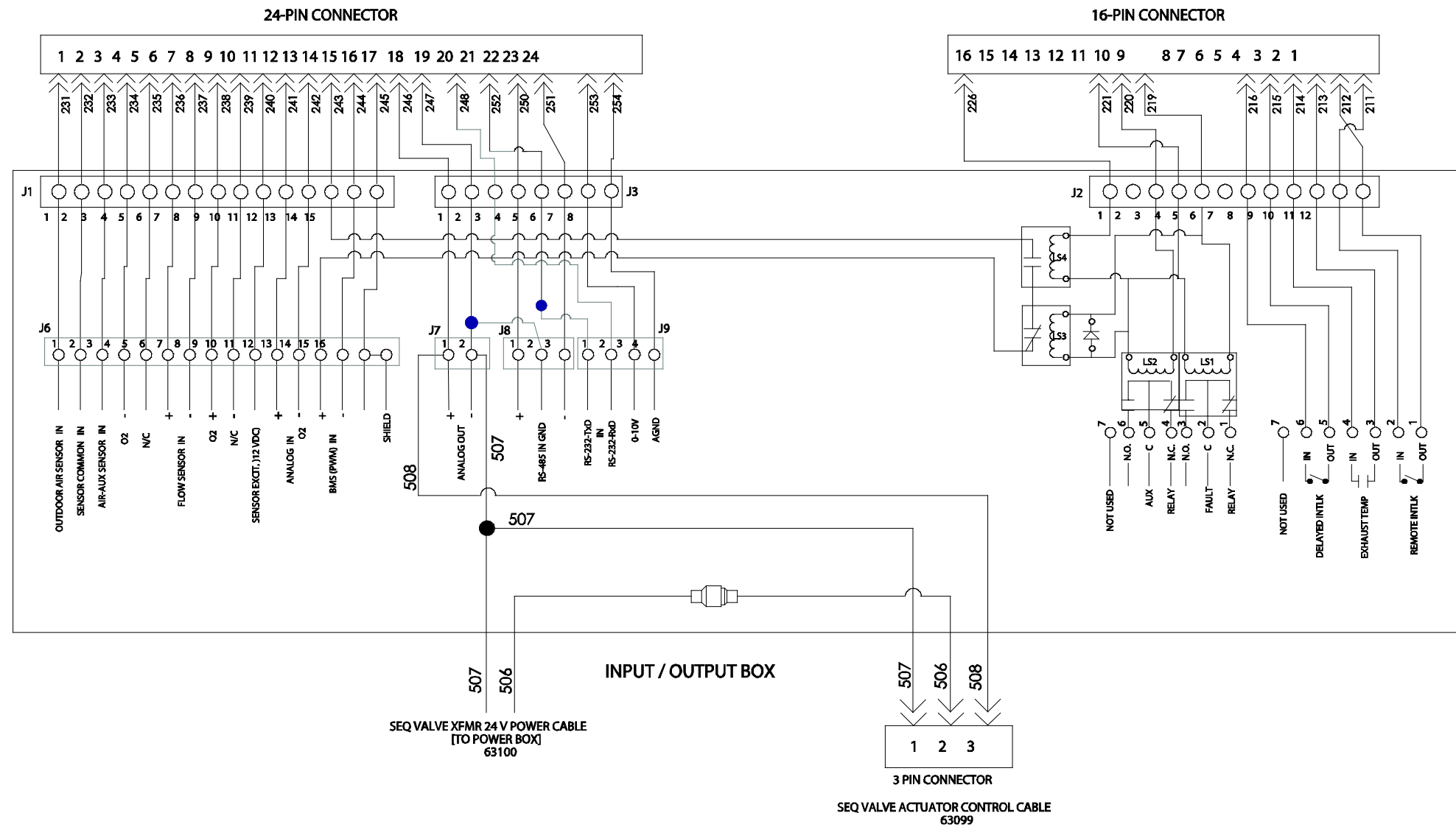

REV	ECO	REVISIONS	DATE	BY	CHKD
1		SEE SHEET 1 OF 2			

THESE DRAWINGS AND/OR SPECIFICATIONS ARE THE PROPERTY OF AERCO INTERNATIONAL, INC. THEY ARE ISSUED IN STRICT CONFIDENCE AND SHALL NOT BE REPRODUCED, COPIED, OR USED AS THE BASIS FOR MANUFACTURE OR SALE OF APPARATUS WITHOUT PERMISSION OF THE OWNER.

THIRD ANGLE PROJECTION	ORIGINAL	DATE	DATE	DATE
	D			
				REV
WIRING SCHEMATIC 120 VAC, 60 Hz INNOVATION w/SEQ. VALVE @ 24 VAC				D
DWG. NO.: 68039				
SHEET 2 OF 2				

This Page Is Intentionally Blank

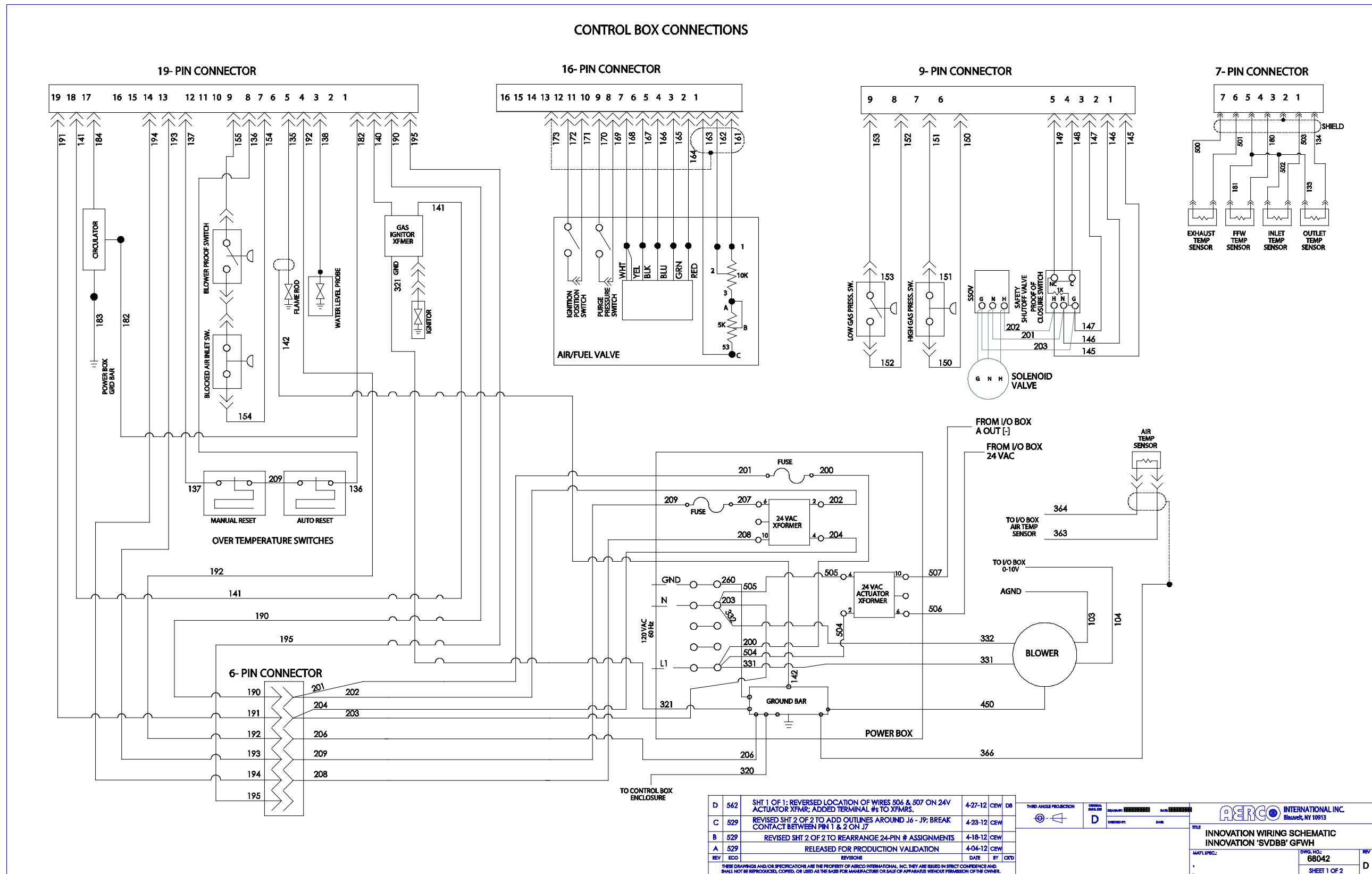

REV	BY	DATE	DESCRIPTION	DATE	BY	CHKD
D	562	4-27-12	SHT 1 OF 1: REVERSED LOCATION OF WIRES 506 & 507 ON 24V ACTUATOR XFMR; ADDED TERMINAL #S TO XFMR.	4-27-12	CEW	DB
C	529	4-23-12	REVISED SHT 2 OF 2 TO ADD OUTLINES AROUND J6 - J9; BREAK CONTACT BETWEEN PIN 1 & 2 ON J7	4-23-12	CEW	
B	529	4-18-12	REVISED SHT 2 OF 2 TO REARRANGE 24-PIN # ASSIGNMENTS	4-18-12	CEW	
A	529	4-04-12	RELEASED FOR PRODUCTION VALIDATION	4-04-12	CEW	
REVISIONS						

THIRD ANGLE PROJECTION	ORIGINAL	DATE	BY	CHKD
	D			

AERCO INTERNATIONAL INC. Blauvelt, NY 10913	
TITLE: INNOVATION WIRING SCHEMATIC INNOVATION 'SVDBB' GFWH	
DATE: 68042	REV: D
SHEET 1 OF 2	

THESE DRAWINGS AND/OR SPECIFICATIONS ARE THE PROPERTY OF AERCO INTERNATIONAL, INC. THEY ARE BASED IN STRICT CONFIDENCE AND SHALL NOT BE REPRODUCED, COPIED, OR USED AS THE BASIS FOR MANUFACTURE OR SALE OF APPARATUS WITHOUT PERMISSION OF THE OWNER.

This Page Is Intentionally Blank





This Page Is Intentionally Blank

**APPENDIX I: RECOMMENDED SPARES**

**NOTE:**

Refer to the Parts List Illustrations in Appendix E for the locations of the recommended and optional spare parts listed in the following Tables.

**Table I-1. Recommended Emergency Spare Parts**

DESCRIPTION	PART NUMBER
120 VAC/Single-Phase Blower	24111
SSOV Actuator/Regulator Combo - Used on: <ul style="list-style-type: none"> <li>• ALL FM gas train models</li> <li>• <b>Downstream</b> SSOV of DBB (IRI) gas train models</li> </ul>	64048
SSOV Actuator <u>Without</u> Proof of Closure Switch - Used on: <ul style="list-style-type: none"> <li>• <b>Upstream</b> SSOV of DBB (IRI) gas train models</li> </ul>	69038
Temperature Switch - Manual Reset (SEE NOTE: 1)	123552

**Table I-2. Spare Parts Recommended for Maintenance**

DESCRIPTION	PART NUMBER
Annual Maintenance Kit	58036-01
24-month Waterside/Fireside Inspection Kit	58036-02

**Table I-3. Optional Spare Parts**

DESCRIPTION	PART NUMBER
C-More Control Box	181197
Burner	46023
Temperature Switch - Auto Reset (SEE NOTE: 1)	123966

**NOTE 1:**

If unit is installed in the State of Kentucky, contact your local AERCO Sales Representative for Temperature Switch rated for 200°F.

This Page Is Intentionally Blank

**APPENDIX J: COMBUSTION CALIBRATION (KOREA ONLY)**

This Page Is Intentionally Blank

**J.1 NATURAL GAS COMBUSTION CALIBRATION**

The Innovation Heater is combustion calibrated at the factory prior to shipping. However, recalibration as part of initial start-up is necessary due to changes in the local altitude, gas BTU content, gas supply piping and supply regulators. Factory Test Data sheets are shipped with each unit. These sheets must be filled out and returned to AERCO for proper Warranty Validation.

It is important to perform the following procedure as outlined below. This will keep readjustments to a minimum and provide optimum performance.

**Natural Gas Combustion Calibration**

1. Open the water supply and return valves to the unit and ensure that the system pumps are running.
2. Open the natural gas supply valve(s) to the unit.
3. Set the control panel ON/OFF switch to the OFF position.
4. Turn on external AC power to the unit. The display will show LOSS OF POWER and the time and date.
5. Set the unit to the Manual Mode by pressing the AUTO/MAN key. A flashing Manual Valve Position message will be displayed with the present position in %. Also, the MANUAL LED will light.
6. Adjust the air/fuel valve position to 0% by pressing the ▼ arrow key.
7. Ensure that the leak detection ball valve downstream of the SSOV is open.
8. Set the ON/OFF switch to the ON position.
9. Change the valve position to 29% using the ▲ arrow key. The unit should begin its start sequence and fire.
10. Next, verify that the gas pressure downstream of the SSOV is within the appropriate range shown below for the Innovation Model being tested. If gas pressure adjustment is required, remove the brass hex nut on the SSOV actuator to access the gas pressure adjustment screw (Figure J-1). Make gas pressure adjustments using a flat-tip screwdriver to obtain a gas pressure reading within the required range for the INN model being tested.

<b>INNOVATION MODEL</b>	<b>GAS PRESSURE RANGE DOWNSTREAM OF SSOV</b>
INN1350	2.8" – 3.0" W.C.
INN1060	2.4" – 2.6" W.C.
INN800	1.3" – 1.5" W.C.
INN600	0.7" – 0.9" W.C.

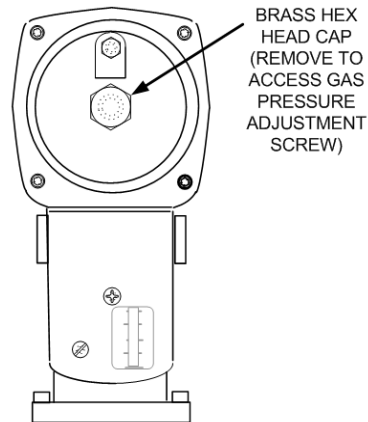

BRASS HEX  
HEAD CAP  
(REMOVE TO  
ACCESS GAS  
PRESSURE  
ADJUSTMENT  
SCREW)

TYPICAL SSOV ACTUATOR WITH REGULATOR

**Figure J-1. Gas Pressure Adjustment Screw Location**

11. Next, decrease the valve open position to 16% using the ▼ arrow key. Verify that the gas pressure at the inlet of the SSOV is 11.0" W.C. Readjust the inlet gas pressure if necessary.
12. Insert the combustion analyzer probe into the 1/8" port at the rear of the exhaust manifold. Allow enough time for the combustion analyzer to settle.
13. Verify that the oxygen (O<sub>2</sub>) level is within the range shown below. Also, ensure that the carbon monoxide (CO) and nitrogen oxide (NO<sub>x</sub>) readings do not exceed the values shown.

**Combustion Oxygen Level at  
16% Valve Position**

Oxygen % ± 0.5	Carbon Monoxide	NO <sub>x</sub>
6.5 %	<50 ppm	<15 ppm

14. If the oxygen level is not within the required tolerance, the gas pressure on the downstream side of the SSOV must be adjusted using the adjustment screw on the SSOV regulator (Figure J-1). Slowly rotate the gas pressure adjustment (approximately 1/4-turn increments). Allow the combustion analyzer to stabilize following each adjustment. Clockwise rotation reduces the oxygen level, while counterclockwise rotation increases the oxygen level.
15. Once the oxygen level is within the required range listed in step 13, the gas pressure on the downstream side of the SSOV should be within the appropriate range shown below for the Innovation Model being tested.

INNOVATION MODEL	GAS PRESSURE RANGE DOWNSTREAM OF SSOV
INN1350	2.8" – 3.0" W.C.
INN1060	2.4" – 2.6" W.C.
INN800	1.3" – 1.5" W.C.
INN600	0.7" – 0.9" W.C.

16. Replace the brass cap on the SSOV gas pressure adjustment if it was previously removed.
17. This completes the combustion calibration procedure.



**APPENDIX K: WARRANTY**  
**INNOVATION WATER HEATER**  
**LIMITED WARRANTY**

This Page Is Intentionally Blank

**LIMITED WARRANTY: INNOVATION GAS-FIRED WATER HEATER**

---

**PRESSURE VESSEL: 10 YEARS NON-PRORATED**

The shell assembly shall carry a non-prorated 10 year limited warranty from date of shipment against leakage due to thermal shock, water side corrosion, mechanical defects or workmanship.

**HEAT EXCHANGER TUBES/COMBUSTION CHAMBER: 10 YEARS**

The heat exchanger/combustion chamber shall carry a 10 year prorated, limited warranty from date of shipment against any condensate corrosion, thermal stress failure, mechanical defects or workmanship. Operation of the heater using contaminated air will void the warranty. The heat exchangers combustion chamber shall not be warranted from failure due to scaling, liming, corrosion, or erosion due to water or installation conditions. **AERCO** will repair, rebuild or exchange, at its option the heat exchanger/combustion chamber according to the following schedule:

<u>Year</u>	<u>Discount From Then Prevailing List Price</u>
5	100%
6	70%
7	60%
8	50%
9	40%
10	30%

**“C-MORE” CONTROL PANEL: 2 YEARS FROM SHIPMENT**

**AERCO** labeled control panels are conditionally warranted against failure for (2) two years from shipment.

**OTHER COMPONENTS: 18 MONTHS FROM SHIPMENT**

All other components, with the exception of the igniter and flame detector, are conditionally guaranteed against any failure for 18 months from shipment.

The warranty as set forth on the back page of the Operations & Maintenance Manual is in lieu of and not in addition to any other express or implied warranties in any documents, or under any law. No salesman or other representative of **AERCO** has any authority to expand warranties beyond the face of the said warranty and purchaser shall not rely on any oral statement except as stated in the said warranty. An Officer of **AERCO** must do any modifications to this warranty in writing. **AERCO MAKES NO WARRANTY OF MERCHANTABILITY OR FITNESS FOR PARTICULAR PURPOSE OR ANY OTHER EXPRESS OR IMPLIED WARRANTIES.** **AERCO** disclaims all responsibility for any special, incidental or consequential damages. Any claim relating to the product must be filed with **AERCO** not later than 14 days after the event-giving rise to such claim. Any claims relating to this product shall be limited to the sale price of the product at the time of sale. The sale of the product is specifically conditioned upon acceptance of these terms.

**LIMITED WARRANTY: INNOVATION GAS-FIRED WATER HEATER**

---

**CONDITIONS OF WARRANTY:**

Should an **AERCO** gas-fired (natural gas, propane, and natural gas/propane dual fuel only) water heater fail for any of the above reasons within the specified time period from the date of original shipment(s), **AERCO** shall at its option modify, repair or exchange the defective item. **AERCO** shall have the option of having the item returned, FOB its factory, or to make field replacements at the point of installation. **In no event shall AERCO be held liable for replacement labor charges** or for freight or handling charges.

**AERCO** shall accept no responsibility if such item has been improperly installed, operated, or maintained – as defined in **AERCO** O&M manual OMM-0001, or if the buyer has permitted any unauthorized modification, adjustment, and/or repairs to the item. The use of replacement parts not manufactured or sold by **AERCO** will void any warranty, express or limited.

**AERCO** shall accept no responsibility if such item has been damaged due to contaminated combustion air containing but not limited to sheetrock particles, plaster board particles, dirt, dust, lint, and corrosive chemicals such as chlorine gas, halogenated hydrocarbons, and Freon.

In order to process a warranty claim a formal purchase order number is required prior to shipment of any warranty item. In addition, the returned item must include a Returned Goods Authorization (RGA) label, attached to the shipping carton, which identifies the item's return address, register number and factory authorized RGA number.

Warranty coverage for all components and equipment mentioned in said warranty are not valid unless the water heater is started up by a factory certified SST (Service, Start-Up and Troubleshooting) Technician and an **AERCO** start-up sheet is completed.

This warranty coverage is only applicable within the United States and Canada. All other geographical areas carry a standard warranty of 18 months from date of shipment or 12 months from startup, whichever comes first.





© AERCO International, Inc., 2012